

The RESEARCH LABORATORY
of
ELECTRONICS

at the
MASSACHUSETTS INSTITUTE OF TECHNOLOGY
CAMBRIDGE, MASSACHUSETTS 02139

Touch Lab Report 5

**Sensorimotor Interactions in the Haptic Perception
of Virtual Objects**

Gerald L. Beauregard and Mandayam A. Srinivasan

RLE Technical Report No. 607

January 1997



Touch Lab Report 5

**Sensorimotor Interactions in the Haptic Perception
of Virtual Objects**

Gerard L. Beauregard and Mandayam A. Srinivasan

RLE Technical Report No. 607

January 1997

This work was supported by the Office of Naval Research Contract N61339-94-C-0087 and Contract N61339-93-C-0083 from the Naval Air Warfare Center Training Systems Division.

**The Research Laboratory of Electronics
MASSACHUSETTS INSTITUTE OF TECHNOLOGY
CAMBRIDGE, MASSACHUSETTS 02139-4307**

SENSORIMOTOR INTERACTIONS IN THE HAPTIC PERCEPTION
OF VIRTUAL OBJECTS

(Order No.)

GERALD L. BEAUREGARD

Boston University, College of Engineering, 1996

Major Professors: H. Steven Colburn, Ph.D.
 Professor of Biomedical Engineering
 Boston University

 Mandayam A. Srinivasan, Ph.D.
 Principal Research Scientist
 Department of Mechanical Engineering
 Massachusetts Institute of Technology

ABSTRACT

The human haptic system, which enables all manual perception and action, is comprised of both tactile and kinesthetic sensory components and a motor subsystem. At present, many basic questions about manual resolution capabilities of the human haptic system remain unanswered. Furthermore, the mechanisms by which the sensory and motor components interact to affect manual resolution are not well understood. To gain insight into both the abilities and mechanisms of haptic perception, a computer controlled electromechanical apparatus, called the Linear Grasper, was used to explore how the human haptic system discriminates some elemental physical properties of objects through active touch.

The investigation consisted of a series of psychophysical studies designed to measure human performance in resolving viscosity and mass. In these experiments, subjects utilized their thumb and index fingers to grasp and squeeze two plates of the Linear Grasper, which was programmed to simulate various stimulus parameters. During the experiments, haptic motor performance data in terms of applied forces, velocities and accelerations were simultaneously recorded. The motor data, in conjunction with the

discrimination results, were used to characterize the sensorimotor performance and to investigate the motor strategies utilized in the sensory discrimination of viscosity and mass by active touch. In a related series of experiments, the manual resolution of velocity and acceleration were measured by using the Linear Grasper to move the passive thumb and index fingers of the subjects. The possible relationship between the sensory resolution limits for these properties and the active discrimination of viscosity and mass was also examined.

The Just Noticeable Difference (JND), a commonly accepted measure of human sensory resolution, was found to be 12% and 20% for viscosity and mass, respectively. An analysis of the motor data lead to the postulation of a simple sensorimotor strategy that explained the motor performance observed in both discrimination experiments: Subjects applied the same temporally controlled forces to all stimuli and discriminated on the basis of differences in the resulting spatial distribution of these forces. This hypothesis was not only consistent with the observed motor data but also successfully explained the measured JND performance for both viscosity and mass.

TABLE OF CONTENTS

1 INTRODUCTION	1
1.1 THESIS ORGANIZATION	2
1.2 RESEARCH BENEFITS	5
2 BACKGROUND.....	7
2.1 THE HAPTIC SYSTEM.....	7
2.2 SENSORY RESOLUTION RESEARCH	8
2.3 MOTOR PERFORMANCE RESEARCH.....	12
2.4 NEUROPHYSIOLOGICAL STUDIES	13
2.5 THESIS GOALS	14
3 THE LINEAR GRASPER.....	17
3.1 INTRODUCTION	17
3.2 SYSTEM OVERVIEW.....	17
3.2.1 Motor-Finger Interface.....	18
3.2.2 Sensors and Instrumentation	19
3.2.3 Data Acquisition	23
3.2.4 Motor Control Hardware.....	28
4 METHOD	29
4.1 INTRODUCTION	29
4.2 VISCOSITY AND MASS DISCRIMINATION EXPERIMENTS: GENERAL METHOD.....	29
4.2.1 Apparatus	29
4.2.2 Subjects.....	31
4.2.3 Procedure.....	31
4.2.4 Data Analysis.....	31
4.2.5 Experiments with Different Fixed Displacements.....	32
4.2.6 Experiments with Different Reference Values	33
4.3 VELOCITY AND ACCELERATION DISCRIMINATION EXPERIMENTS.....	34
4.3.1 Apparatus	34
4.3.2 Subjects.....	35
4.3.3 Procedure.....	35
4.3.4 Data Analysis.....	36
4.3.5 Experimental Parameters	36
5 VISCOSITY DISCRIMINATION RESULTS.....	38
5.1 JUST NOTICEABLE DIFFERENCE	38
5.1.1 Fixed Displacement Results	38
5.1.2 Different Reference Results	39
5.1.3 Overall Results.....	41
5.1.4 Anecdotal Subject Observations	41
5.2 MOTOR PERFORMANCE	42
5.2.1 Fixed Displacement Experiments	42
5.2.2 Experiments with Different Reference Values	45
5.2.2.1 Force Data	46
5.2.2.2 Velocity Data	52

6 MASS DISCRIMINATION RESULTS	58
6.1 JUST NOTICEABLE DIFFERENCE	58
6.1.1 Fixed Displacement Results	58
6.1.2 Different Reference Results	59
6.1.3 Overall Results.....	61
6.1.4 Anecdotal Subject Observations	61
6.2 MOTOR PERFORMANCE	62
6.2.1 Fixed Displacement Experiments	62
6.2.1.1 Force Data	62
6.2.1.2 Acceleration Data.....	67
6.2.2 Motor Performance for Different Reference Masses.....	71
6.2.1.1 Force Data	71
6.2.1.2 Acceleration Data.....	76
7 VELOCITY AND ACCELERATION RESULTS.....	80
7.1 VELOCITY JND RESULTS.....	80
7.2 ACCELERATION JND RESULTS.....	82
8 ANALYSIS OF SENSORIMOTOR INTERACTIONS	84
8.1 INTRODUCTION	84
8.2 ANALYSIS OF MOTOR PERFORMANCE DATA	85
8.2.1 Average Temporal Force Ramps are the Same for Both Stimuli	85
8.2.2 Force Ramps are Substantially Linear with Respect to Time.....	89
8.3 A THEORY ON ACTIVE PINCH DISCRIMINATION.....	91
8.3.1 An Initial Grasp Premise.....	91
8.3.2 Constraints on the Initial Grasp Strategy.....	92
8.3.3 Implications of the Linear temporal Force Ramp Model.....	92
8.3.4 Possible Discrimination Hypotheses Consistent with the Motor Data.....	94
8.3.5 The Temporal Force Control- Spatial Force Discrimination Hypothesis for Active Touch Discrimination.....	99
8.3.6 Implications of the Theory	99
8.3.7 Modifications to the Theory	102
8.3.8 Model Predictions for the Force and Motional Data.....	103
8.4 ANALYSIS OF THE COEFFICIENT OF VARIATION DATA	107
9 DISCUSSION	110
9.1 SUMMARY OF RESULTS	110
9.2 FUTURE WORK.....	115
9.2.1 Complex Object Perception	115
9.2.2 Multimodal Perception of Object Properties	115
9.3 CONCLUSION	116
APPENDIX A	117
APPENDIX B	121
APPENDIX C	140
APPENDIX D	159
BIBLIOGRAPHY	187

LIST OF FIGURES

Figure 3.1	System Block Diagram	18
Figure 3.2	Motor Finger Interface.....	19
Figure 3.3	Position versus Time for Different Applied Forces	22
Figure 3.4	Block Diagram of Basic Data Acquisition and Control Algorithm	24
Figure 3.5	Discrete Realization of the Feedback Control System.....	26
Figure 3.6	Typical Velocity Plots versus Displacement	28
Figure 4.1	The Layout of the Linear Grasper during an Experimental Trial.....	30
Figure 5.1	Viscosity JND versus Fixed Displacement	40
Figure 5.2	Viscosity JND versus Reference.....	40
Figure 5.3	Typical Force and Velocity Data vs Time For Subject LR	43
Figure 5.4	Typical Force and Velocity Data vs Distance For Subject LR.....	43
Figure 5.5	Typical Force and Velocity Data vs Time For Subject BS	43
Figure 5.6	Typical Force and Velocity Data vs Distance For Subject BS	43
Figure 5.7	Typical Force and Velocity Data vs Time For Subject BR.....	43
Figure 5.8	Typical Force and Velocity Data vs Distance For Subject BR.....	43
Figure 5.9	Average Force for all Subjects in Fixed Displacement Experiments	45
Figure 5.10	Average Velocity for all Subjects in Fixed Displacement Experiments	45
Figure 5.11	Applied Force versus Time Plots.....	47
Figure 5.12	Applied Force versus Distance Plots	48
Figure 5.13	Velocity versus Time Plots.....	54
Figure 5.14	Velocity versus Distance Plots	55
Figure 6.1	Mass JND versus Fixed Displacement	59
Figure 6.2	Mass JND versus Reference Mass.....	60
Figure 6.3	Applied Force versus Time Plots.....	63
Figure 6.4	Applied Force versus Distance Plots	64
Figure 6.5	Acceleration versus Time Plots.....	69
Figure 6.6	Acceleration versus Distance Plots.....	69
Figure 6.7	Applied Force versus Time Plots (for Different Reference Masses)	72
Figure 6.8	Applied Force versus Distance Plots (for Different Reference Masses)	73
Figure 6.9	Acceleration versus Time Plots (for Different Reference Masses).....	76
Figure 6.10	Acceleration versus Distance Plots(for Different Reference Masses).....	77
Figure 7.1	JND Results for the Viscosity Discrimination Experiments.....	81
Figure 7.1	JND Results for the Viscosity Discrimination Experiments.....	81
Figure 7.2	JND Results for the Acceleration Discrimination Experiments	83
Figure 8.1	Typical Average Force Ramps for $\Delta B/B = 10\%$	86
Figure 8.2	Typical Average Force Ramps for $\Delta B/B = 25\%$	87
Figure 8.3	Typical Average Force Ramps for $\Delta M/M = 10\%$	87
Figure 8.4	Typical Average Force Ramps for $\Delta M/M = 40\%$	88
Figure 8.5	Typical Force Ramp Data for Subject ZS	90
Figure 8.6	Actual versus Predicted JNDs for Viscosity.....	98
Figure 8.7	Actual versus Predicted JNDs for Mass.....	98
Figure 8.8	Force versus Displacement Data for Subject ZS	100
Figure 8.9	Comparison of Spatial Mean Force Differences	102
Figure 8.10	The Distribution of Slope Data for Subject ZS	103
Figure 8.11	Actual versus Predicted Spatial Mean Force Results	105
Figure 8.12	Actual versus Predicted Spatial Mean Velocity Results	105
Figure 8.11	Actual versus Predicted Spatial Mean Force Results	106
Figure 8.12	Actual versus Predicted Spatial Mean Acceleration Results.....	106

LIST OF TABLES

Table 3.1	Values of k for different Applied Forces	23
Table 5.1	JND Results for Fixed Displacement Experiments.....	38
Table 5.2	Bias Results for Fixed Displacement Experiments.....	39
Table 5.3	JND Results for Different References	39
Table 5.4	Bias Results for Fixed Displacement Experiments.....	39
Table 5.5	Force and Velocity Data during the Fixed Displacement Experiments.....	44
Table 5.6	Summary Force Data for Reference Viscosity = 60Ns/m	51
Table 5.7	Summary Force Data for Reference Viscosity = 120Ns/m.....	51
Table 5.8	Summary Force Data for Reference Viscosity = 180Ns/m.....	52
Table 5.9	Summary Velocity Data for Reference Viscosity = 60Ns/m	56
Table 5.10	Summary Velocity Data for Reference Viscosity = 120Ns/m	56
Table 5.11	Summary Velocity e Data for Reference Viscosity = 180Ns/m.....	57
Table 6.1	JND Results for Fixed Displacement Experiments.....	58
Table 6.2	Bias Results for Fixed Displacement Experiments.....	59
Table 6.3	JND Results for Different References	60
Table 6.4	Bias Results for Fixed Displacement Experiments.....	61
Table 6.5	Average Force Data During the Fixed Displacement Experiments.....	66
Table 6.6	Force Results by Subject During the Fixed Displacement Experiments.....	67
Table 6.7	Average Acceleration Data During the Fixed Displacement Experiments.....	66
Table 6.8	Acceleration Results by Subject During the Fixed Displacement Experiments.....	67
Table 6.9	Summary Force Data for 6kg	74
Table 6.10	Summary Force Data for 9kg	75
Table 6.11	Summary Force Data for 12kg	75
Table 6.12	Average Acceleration Data by Reference Mass	78
Table 6.13	Average Acceleration Data by Subject.....	78
Table 7.1	JND Results for Velocity Discrimination	81
Table 7.2	Bias Results for Velocity Discrimination	81
Table 7.3	JND Results for Acceleration Discrimination Experiments.....	82
Table 7.4	Bias Results for Acceleration Discrimination Experiments.....	83
Table 8.1	Percent Difference in Mean Ramp Force	89
Table 8.2	Correlation Coefficient Values for Linearity of Force Ramp Data.....	90
Table 8.3	Actual versus predicted JND Results.....	97
Table 8.4	Mean Spatial Force Differences in the First Ten Millimeters.....	100
Table 8.5	Overall Coefficient of Variation Results.....	107
Table 8.6	Trial-to-Trial Variation Results.....	108

1

Introduction

Our hand is a remarkably versatile organ. It is through our hands that we interact with the environment. In fact the world around us is structured to take advantage of the versatility and dexterity of our hands: virtually every task we perform requires some degree of manual activity. Sometimes even a rare exception, like conversation, finds our hands playing a meaningful role. Our ability to use our hands to perform common tasks such as feeling the texture of an object or manipulating a tool requires the integrated action of complex sensory, motor and cognitive physiological systems.' The term, *haptics*, refers to this overall sensorimotor-cognitive system that makes manual activity possible.

Virtual environments are computer generated synthetic environments. Ideally, human users can interact with these environments to carry out a wide range of sensory, motor, and cognitive-based tasks. However, current virtual environments (VE) are predominantly visual and auditory based and support only limited haptic interaction. Thus the ubiquitous role that our hands play in the natural environment is greatly curtailed in the VE world. This occurs because of difficulty in designing haptic interfaces (i.e. platforms that facilitate manual interaction in synthetic environments) that are well matched to the resolution and capabilities of the human haptic system. Some of the difficulty arises from current technological limitations in building sophisticated tactual stimulators. However, another major roadblock for the design of effective haptic interfaces is a lack of understanding about the basic haptic processes of the human user.

Compared to our understanding of vision and audition, our knowledge of the human haptic perception is very limited. Many basic questions about the resolution and capabilities of the haptic sense remain unanswered. Furthermore, the mechanisms by which the different sensory and motor components interact to affect manual perception are not well understood. To gain insight into both the abilities and mechanisms of the haptic perception, a computer controlled electromechanical device, called the Linear Grasper, was utilized to explore how the human haptic system discriminates elemental physical properties of objects through active touch.

Specifically, the goal was to measure the manual resolution of viscosity and mass through active pinch grasping and to study the underlying sensorimotor mechanisms involved in the manual perception of these fundamental physical properties. The investigation partly consisted of a series of psychophysical studies designed to measure human performance in discriminating these properties. During the experiments, haptic motor performance data in terms of applied forces, velocities and accelerations were simultaneously recorded. The motor data, in conjunction with the discrimination results, were used to characterize the sensorimotor performance and to investigate the motor strategies utilized in the sensory discrimination of viscosity and mass by active touch. In a related series of experiments, the passive manual resolution of velocity and acceleration were measured and the possible relationship between the sensory resolution limits for these properties and the discrimination of viscosity and mass was also examined.

1.1 Thesis Organization

As an aid to the reader, the basic organization of the body of this thesis is described below:

In Chapter 2, a background is provided by examining studies that have previously investigated the haptic discrimination of object properties. The reviewed research includes pertinent sensory resolution studies, appropriate motor control and performance investigations, and some neurophysiological studies. From the framework of these studies, the specific goals of the thesis research are stated at the end of the chapter.

The experimental apparatus is described in Chapter 3. The description includes a discussion of the Linear Grasper's physical structure and operating capabilities. In addition, the associated sensors, instrumentation and data acquisition equipment needed to perform the experiments are also characterized and the calibration procedures utilized are presented. The chapter also elucidates the basic structure of the software algorithms employed to control the device so that the appropriate stimuli were presented during the experiments.

The experimental method is presented in Chapter 4. The first half of the chapter includes a description of the procedures, experimental parameters and data analysis methods used for the viscosity and mass discrimination experiments. The second half the chapter is similarly organized for the velocity and acceleration discrimination experiments.

The sensory resolution and motor performance results for the viscosity and mass discrimination experiments conducted under active touch conditions are presented in Chapters 5 and 6, respectively. In both chapters, the sensory resolution results are presented first followed by the motor performance data. The sensory resolution results include data from all experimental conditions along with computed overall average results and anecdotal observations. The motor data include mean, standard deviation, and maximum values for the forces, velocities and accelerations measured during the experiments and are organized by stimulus and subject. The emphasis of these chapters is on providing basic human factors data on the measured sensory resolutions and the associated motor performance of the subjects. In addition to this general characterization of the data, some important stimulus-dependent differences in the motor data are also highlighted for later explanation in Chapter 8.

In Chapter 7, the sensory resolution results for the velocity and acceleration discrimination experiments conducted under passive touch conditions are presented. Because the goal of these experiments was to explore the possible relationship between the sensory resolution limits for velocity and acceleration and the discrimination of viscosity and mass, the stimuli in the experiments were chosen to cover the same range of

velocities and accelerations used in the viscosity and mass discrimination experiments. The sensory resolution data are presented for all these experimental conditions and overall averages are also computed.

In Chapter 8, an analysis of the motor data leads to the postulation of a sensorimotor strategy capable of explaining the sensory resolution and motor performance observed for all the subjects in the viscosity and mass discrimination experiments. A general statement of the hypothesized strategy is as follows.

Temporal Force Control–Spatial Force Discrimination (TFC–SFD) Hypothesis:

To discriminate mechanical impedance of objects, subjects apply, on average, the same temporally controlled forces to all stimuli and discriminate on the basis of differences in the resulting spatial distribution of these forces.

This hypothesis is first developed by showing that subjects use statistically the same initial temporal forces profiles for all viscosity and mass stimuli and these profiles can be well approximated as linear ramps. Next, a simple mathematical model is developed to show that the same linear force ramp in time will give rise to different spatial distributions of force and motion depending on the viscosity or mass of the stimuli being squeezed. From the model, predictions for the manual resolution of viscosity and mass are made and compared with the actual results presented earlier in Chapters 5 and 6. The results indicate that the spatially based force discrimination hypothesis could successfully explain the measured JND performance for both viscosity and mass. It is also consistent previous observations on the discrimination of mechanical compliance (Tan et al, 1995). The next section of the chapter focuses on other implications and predictions of the hypothesis such as showing how the model can explain observed stimulus-dependent motor data. The final part of the chapter is devoted to a more detailed discussion of the variation in motor performance during the discrimination experiments.

A summary of the thesis and a discussion of the results are presented in Chapter 9 along with a brief section on potential areas of future research and study. In regard to the appendices, background material on the psychophysical decision model utilized to measure

sensory resolution is presented in Appendix A. In Appendices B and C, typical plots of recorded motor performance data for the viscosity and mass discrimination experiments are presented. Finally, Appendix D contains a listing of the software source code used to control the Linear Grasper during the experiments.

1.2 Research Benefits

It is anticipated that the results of this research will support the development of better hardware and software for haptic interactions in virtual environments. First, the quantitative determination of the capabilities of the human haptic system is an important part of understanding limitations in the manual perception of object properties. This knowledge has two potential benefits for haptic interface design: (1) It helps determine necessary parameter values for simple “virtual objects” to ensure that they are manually discriminable in a particular VE application and (2) Knowledge of limitations in haptic resolution could give rise to VE rendering techniques that exploit these limitations to create satisfying synthetic haptic experiences. This second possibility is analogous to the use of a cinematic film projection rate of thirty frames per second to create the realistic sense of temporally continuous visual imagery in motion pictures.

Second, it is anticipated that this quantitative investigation of the human haptic system will provide meaningful human factors data. This data, along with human factors information from other researchers, should help in the generation of design specifications for haptic interface components. For example, having data on the human sensory resolution of various object properties as well as the range of applied forces, velocities and accelerations utilized in manual tasks should better equip haptic interface designers in specifying the appropriate sensors, actuators, and other hardware for their VE applications.

Finally, by seeking to gain insight into the sensorimotor strategies involved in manual discrimination, it is hoped that this research will contribute to the eventual identification of the fundamental mechanisms involved in haptic perception. An understanding of fundamental mechanisms in haptic perception would greatly facilitate the

modeling and prediction of manual resolution capabilities for a wide range complex objects. This would have important practical implications not only in the development of haptic interfaces for virtual environments, but also for other man-machine applications such as teleoperation. It would also facilitate the design of autonomous robots that must make use of manual sensing and manipulation.

In coming full circle, it is hoped that the development of better haptic interfaces will not only provide a means for expanding the opportunity for manual activity in virtual environments, but eventually provide new and exciting experimental platforms for further investigating the mechanisms of haptic perception by itself and in conjunction with other sensory modalities.

2

Background

2.1 The Haptic System

The human haptic system consists of tactile and kinesthetic (proprioceptive) sensory components as well as a motor subsystem. The tactile sensory part consists of at least four separate classes of mechanoreceptive organs involved in sensing the nature of contact between an object and the hand, in addition to other sensory organs activated by temperature and chemical stimuli. The kinesthetic sensors, located in the joints, tendons and muscles together with motor command derived neural signals provide information about limb position and velocity as well as associated forces (Srinivasan, 1994).

In concert with the haptic motor system, the sensory components are used to explore, grasp and manipulate objects in the environment. An example of this is a typical exploration task involving active contact between the hand and a physical object. During this activity, manual contact forces are controlled by motor commands to the appropriate muscle groups to enable touching, probing and grasping of the object. Throughout this process, valuable information from tactile and kinesthetic sensory organs is acquired. This information is used to modify and control the conditions of contact and is cognitively processed to create perceptual impressions of the object's properties. Typical object properties that might be perceived during haptic exploration include geometric attributes such as shape and size; textural properties such as roughness and fabric; and physical characteristics such as stiffness and mass.

A hallmark of all haptic activities involving active contact is a natural interaction between the sensory and motor subsystems. This is true regardless whether the task is primarily sensory or motor based. For example, to acquire useful sensory information in an exploration task, like the one illustrated in the above example, appropriate motor actions must be utilized. Likewise in a manipulation task, such as using a tool, the motor driven activity needs sensory feedback for successful performance. Thus, in both exploration and manipulation, the limitations of either sensory or motor subsystem will affect the overall performance of the system.

This research is concerned with studying how the haptic system discriminates the physical properties of viscosity and mass through the mechanism of active pinch grasping. Therefore, to provide a meaningful background it is useful to review previous studies that have investigated various aspects of both subsystems from standpoint of understanding the discrimination of object properties.

Relevant research includes studies that have measured the sensory resolution limits of the haptic system for other fundamental physical properties of objects; studies that have quantified or described the motor actions utilized during discrimination tasks; investigations that have been carried out into the roles that tactile and kinesthetic sensory receptors play in the haptic perception of physical properties; motor control studies that have investigated the effect that physical properties have on motor performance; and research that has studied the underlying neurophysiological nature of sensorimotor mechanisms involved in fundamental haptic tasks such as grasping and picking up objects.

2.2 Sensory Resolution Research

Sensory resolution experiments exploring the haptic perception of physical properties of objects have primarily focused on measuring the sensitivity to fundamental mechanical characteristics such as stiffness and force and basic physical properties such as object length. A prime motivation for this approach is that the approximate mechanical behavior of many deformable objects can be represented by the linear sum of the elemental properties of constant force, stiffness, viscosity and mass; thus by obtaining information on

perception of these fundamental mechanical properties, it is hoped that an understanding of the haptic perception of more complicated objects will also be advanced. Other relevant sensory resolution studies also include those that have explored the more general perception of position, and movement within the haptic system. Some of these investigations have also examined the influence of physical properties such as force and viscosity on the perception of position and velocity.

A summary of sensory resolution studies involved in directly measuring the ability to resolve various mechanical and physical properties of objects is presented in Table 2.1. Some of the research has focused on manual resolution (i.e., primarily involving the fingers of the hand), while other investigations have examined perception involving one or both forearms. Generally all the studies have focused on measuring sensory resolution limits and only to a much lesser degree attempted to characterize and analyze the motor performance used during the discrimination tasks.

Study	Property	Results
Durlach, et al (1989)	Object length	JND decreased from 10% at 10mm to 3% at 80mm.
Pang, et al (1991)	Force	JND of approximately 7% over a range of fixed displacements and reference forces.
Tan, et al (1992, 1995)	Compliance	JND of 8% over a range of fixed displacements. JND of 22% when terminal force and mechanical work cues are roved. JND ranged from 15% - 99% when mechanical work cues were eliminated.
Jones & Hunter (1989, 1990a, 1992a, 1992b, 1993)	Force, movement, stiffness, and viscosity	Differential sensory thresholds of 7%, 8%, 23% and 34% were measured for force, movement, stiffness and viscosity, respectively.

Table 2.1: Sensory Resolution Studies of Physical Properties

In research exploring manual resolution under active touch using the thumb and forefinger in a pinch grasp, Durlach et al (1989), reported a Just Noticeable Difference (JND) for object length that increased monotonically from approximately 1 mm for a reference length of 10 mm to 2.4 mm for a reference length of 80 mm. The JND can be viewed as a measure of sensory resolution. Under similar experimental conditions, Pang et al (1991), found the JND for constant force to be roughly 7% over a range of reference forces from 2.5 to 10 Newtons (N), and fixed pushing displacements ranging from 5 to 30 mm. These results are consistent with earlier studies of force and weight discrimination (see review by Jones, 1986). Pang et al also reported that the subjects' average pushing velocities varied under different test conditions from 57.0 to 117.7 mm/s.

The ability to manually discriminate mechanical compliance¹ using the pinch grasp has been investigated over a range of experimental conditions and the results are less consistent. When no constant force offset is present and stimuli are presented over a fixed displacement interval, compliance JNDs of 8% have been reported (Tan et al 1992). A reference compliance of 4 mm/N and different fixed displacement intervals of 15, 20, 25, 30 and 35 mm were used. However, in all experimental conditions, terminal force cues and mechanical work cues (the applied force integrated over displacement) were consistent with compliance and are likely to have played a role in the discrimination process. When these cues were then disassociated from compliance by using a roving displacement paradigm, compliance JND increased to 22%. Furthermore, when trial-by-trial response feedback was eliminated, the JND remained at 22% and subjects appeared strongly biased to select the stimuli with greater terminal forces and mechanical work values as less compliant (Tan et al 1995). Finally, when mechanical work cues were totally eliminated, compliance JND ranged from 15%–99% and discrimination performance over all experimental conditions could be parsimoniously described by a terminal force JND of approximately 5% (Tan et al 1995). Thus it appears force and work cues are important in compliance discrimination.

¹ Mathematically, compliance is the inverse of stiffness or $C = 1 / K$, where K is the ratio of force to displacement.

Jones and Hunter have performed a series of experiments to measure the perception of movement, force, stiffness and viscosity using a contralateral limb-matching procedure with the forearms (Jones, 1989; Jones & Hunter, 1990a; Jones & Hunter, 1992a; Jones & Hunter, 1992b; Jones & Hunter, 1993a). They reported differential sensory thresholds of 7% and 8% for force and movement respectively. In analyzing thresholds for stiffness and viscosity, they found significant loss in perceptual resolution. Their results showed an average differential threshold for 23% for stiffness and 34% for viscosity. The magnitude of the reference stiffness ranged from 0 to 6260 N/m and reference viscosity values varied from 2 N-s/m to 1024 N-s/m in their experiments. They hypothesized that the loss in resolution was because force cues had to be integrated with limb position and velocity information.

Stevens and Guirao (1964) and Scott-Blair and Coppen (1940) performed general studies on perception of fluid viscosity. Scott-Blair and Coppen reported that subjects had an 80% correct response rate when presented with bitumen samples differing in viscosity by 30%. In a magnitude estimation procedure, Stevens and Guirao found that subjects estimated that the viscosity of silicone fluids grew as absolute viscosity raised to a fractional power that varied from 0.42 to 0.46. Subjects made judgments under three procedures: stirring the liquid with a rod with the eyes open, stirring the liquid with the eyes blindfolded and just shaking or turning the bottle containing the liquid. The effect of visual and haptic information in the first procedure as opposed to haptic only input in the second procedure did not seem to influence the magnitude estimation responses.

In mass discrimination experiments carried out in zero-gravity conditions, Ross et al. (1984), reported that the subjects' Weber fractions for mass were approximately double their Weber fractions for weight (8 - 15%) obtained for the same objects in an 1-G environment. In related studies involving the perception of the moment of inertia, investigators have reported differential sensory thresholds ranging from 28% (Kreifeldt and Chuang, 1979) to 113% (Ross and Benson, 1986).

Some of these investigations have also examined the influence of some physical properties like force and viscosity on the perception of physical properties like position and velocity. Watson et al (1984) reported that errors in matching the position of the left index with the right one increased with the stiffness of an elastic load applied to the wrists. However, when asked to match force instead of position, the errors were generally independent of the relative starting position of the two fingers. Milner (1986) has reported that the ability to accurately reproduce target peak velocities with rapid flexion of the interphalangeal joint of the thumb was degraded for half of his subjects when viscous loads were intermittently applied to the thumb. Thus, the ability to sense and control velocity may be influenced and degraded by the presence of viscosity, although there were only six subjects in this experiment and each subject completed only a total of 80 movements.

2.3 Motor Performance Research

While a significant amount of research has been carried out on human motor performance and motor control (for example, Hogan, 1984; Bizzi, 1984; Shadmehr, 1993; and also see reviews by Keele, 1986; and Wickens, 1986), the most pertinent research for this investigation are those studies that have focused on examining the motor strategies that are utilized in haptic discrimination or exploration tasks. Unfortunately, very few investigations have been carried out that have attempted to describe and quantify the motor strategies in these tasks.

The most notable exception is the work by Lederman and Klatzky (1987, 1990) and Klatzky et al (1991, 1992 and 1993). These experiments investigated the relationship between the desired knowledge about certain object properties, for example texture or temperature, and the hand movements used to acquire information about these properties. The results suggest that different exploratory procedures are used to ascertain different object properties, and these procedures are utilized not only because they are sufficient for performing the task but because they are optimal or necessary. Some examples of the exploratory hand movement procedures they describe include movement patterns such as

lateral motion, static contact and unsupported holding. While these procedures are well described in the results of the experiments, data on applied forces, and speeds or accelerations of movements utilized in the exploratory procedures were not measured.

In motor performance research more tangentially related to this thesis, Jones and Hunter (1992b) explored the influence of viscosity and stiffness on human operator motor control performance. Their experiments were typically position tracking tasks involving a manipulandum and visual feedback. They found that tracking performance was enhanced with increases in either stiffness and viscosity. They hypothesized that the improved performance was a result of increased kinesthetic feedback that provided additional information to the operator. They also investigated isometric force tracking and found that while operator response times were improved over position tracking, steady state tracking errors were also greater.

2.4 Neurophysiological Studies

Studies interested in illuminating the role of different sensory systems involved in the perception of mechanical properties have also been carried out. Roland and Ladegaard-Pedersen (1977) examined the ability of subjects in discriminating the stiffness of two springs held in the hand. The aim of their research was to study the role of cutaneous and joint sensory receptors in the perception of stiffness. They found that the ability to discriminate stiffness was unaffected by local anesthesia of the skin and joints involved in squeezing the springs. They theorized that tension sensing Golgi organs and muscle spindles provided sufficient information for stiffness perception. Their results are similar to that of Srinivasan and LaMotte (1995) who have shown that the mechanisms of compliance discrimination depend on the nature of the object's surface. They found that the discrimination of stiffness with springs having rigid surfaces requires kinesthetic information, whereas purely tactile information from mechanoreceptors in the fingerpad is adequate for discriminating compliant material with deformable surfaces, such as rubber specimens with variable compliances.

In another series of experiments, Johansson and Cole (1992) investigated goal directed grasping and lifting of small objects held in a pinch grasp. Sensors were mounted on the objects to monitor grip force, load force, acceleration and position. In addition, neurophysiological recordings were made from tactile afferent fibers during the manipulation process. The results indicated that humans maintained a consistent ratio of applied lifting and grip forces to avoid conditions of slip. In addition, when anesthesia was used to block tactile afferent information from the contact area, control performance was significantly degraded. They postulated that subjects used tactile sensory information about mechanical events such as microstiffness in the contact area to activate anticipatory motor control strategies to minimize object slip. These anticipatory strategies, they believed, are predictive feedforward mechanisms that are derived from past experiences with the grasping and lifting task.

2.5 Thesis Goals

To summarize, past research has focused on measuring human sensory resolution limits of basic physical properties, understanding the role of specific sensory populations in perception and control, and either exploring how motor performance is influenced by changing specific mechanical properties of manipulated objects or describing the general classes of actions taken during haptic exploration. This thesis plans to build onto this body of research in a number of ways. First of all, discrimination experiments are proposed to measure the manual resolution of viscosity and mass. These experiments will provide data on the ability of the hand to resolve differences in mass and viscosity through pinch grasping. This work will be carried out with the same methods and apparatus as earlier work by Pang et al (1991) on constant force discrimination and Tan et al (1995) on compliance discrimination. The results will therefore allow us to determine if there is a loss in perceptual resolution when the discrimination task requires force cues to be combined with derivative based displacement cues, as was observed by Jones and Hunter (1993a) in their experiments involving viscosity discrimination with the forearms. For the

benefit of improved haptic interface design in virtual environments and teleoperation, these results will also provide practical human performance data.

Second, since all active manual interactions, including those in sensory dominant tasks, involve the human motor system, this part of the thesis will also focus on quantifying and characterizing the motor performance strategies used by subjects during the discrimination tasks. A number of questions that are of interest from a basic scientific viewpoint and also from the perspective of haptic interface design will be explored:

- What are the ranges of applied forces, velocities and accelerations utilized by the subjects during discrimination? Are these ranges influenced by the nature of the stimuli?
- Do subjects exhibit any apparent motor strategies to assist in discrimination? For example, do subjects attempt to squeeze a viscous object with a constant force or grasp it with a constant squeezing velocity? Are the motor strategies different for mass and viscosity discrimination?
- How stereotypical is the motor performance among subjects? In other words, do all subjects squeeze the stimuli in a similar fashion or are there large discrepancies in the nature of the force profiles among subjects?
- What is the variability in motor performance for a particular subject? Is there a correlation between discrimination performance and motor performance?

It is anticipated that by exploring questions such as these, in addition to measuring sensory resolution limits, insight will also be gained into the role motor performance plays in the discrimination process under active touch conditions.

Finally this thesis proposes to measure the manual resolution of velocity and acceleration. Along with the work by Durlach et al (1989), this will provide a complete set of human factors data on the ability to manually assess length, velocity and acceleration. These experiments were performed under passive conditions (involving little

or no motor input from subjects) in order to provide information about very basic sensory resolution limits in the haptic system. In addition, the results from these experiments were analyzed in conjunction with data from the viscosity and mass discrimination experiments to determine if any relationship exists between velocity and viscosity JNDs as well as between acceleration and mass JNDS.

3

The Linear Grasper

3.1 Introduction

The apparatus used in all the discrimination experiments is a one degree of freedom stimulator called the Linear Grasper. It is a computer controlled electromechanical device that can exert bi-directional forces along a linear track. For active tasks, subjects interacted with the apparatus by grasping and squeezing two parallel aluminum plates with their thumb and forefinger which resulted in the travel of one of the plates along the linear track towards the other plate whose position was fixed. In response to this active finger motion, the Linear Grasper was programmed to produce a resisting force proportional to velocity in the viscosity discrimination experiments and to acceleration in the mass discrimination experiments. Finger motion was halted when the moveable plate pushed by the thumb came into contact with a mechanical stop placed at a fixed distance along the linear track.

3.2 System Overview

The apparatus consists of four major components: (1) A motor-finger interface that serves as the actuating mechanism, (2) a component consisting of sensors and associated instrumentation that measures the applied forces and displacements during the experiments, (3) a personal computer system that performs the data acquisition and control of the device and (4) a power amplifier that provides the necessary drive signals to the actuator. A system block diagram is shown in Figure 3.1. A description of the components is given below:

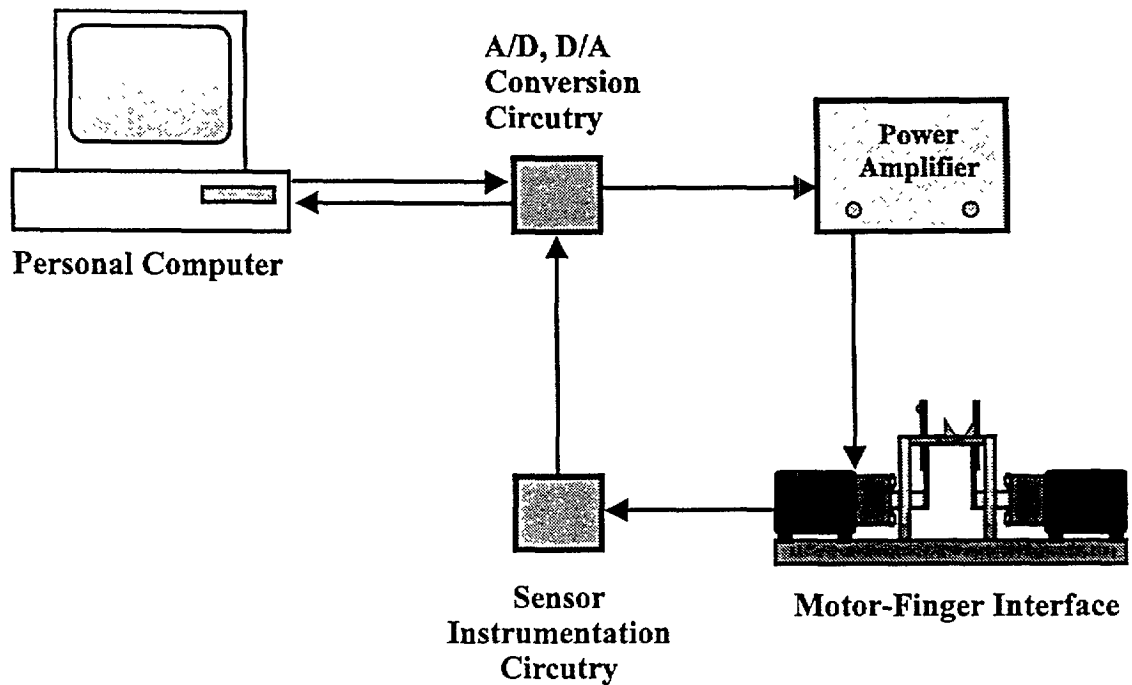

Figure 3.1: *System Block Diagram*

3.2.1 Motor-Finger Interface

The motor-finger interface, shown in Figure 3.2, consists of a DC linear-motion motor attached to a moveable finger plate assembly. The motor consists of a permanent magnet surrounding an armature coil that is mounted around a moveable piston. When current is passed through the coil, a resulting force is exerted on the piston. The magnitude of the force is linearly proportional to the absolute value of the current. The direction of the current through the coil determines the direction of the force. Hence, a positive flowing current will generate a force that acts in the opposite direction of a force created by a negative flowing current. The maximum force that could be generated by the motor was 50N.

The piston is connected to a moveable finger plate assembly. Attached to a flat aluminum plate on the top of the finger plate assembly is either a cylindrical roller or a molded thumb support. The cylindrical roller serves as a consistent point of contact for the subject's thumb during the viscosity and mass discrimination experiments. The

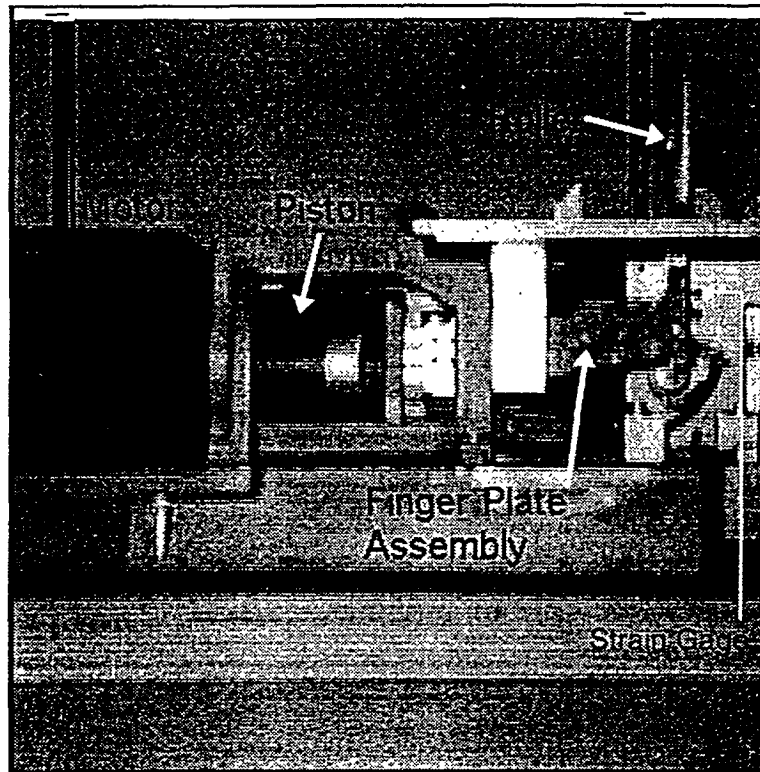

Figure 3.2: *Motor Finger Interface*

support is used to support the thumb during the velocity and acceleration discrimination experiments. The finger plate assembly was confined to travel along a linear track by a supporting mechanical structure. The distance the assembly can travel is determined by a mechanical stop placed in the supporting mechanical structure at the opposite end of the linear track. The location of the stop was adjustable so that fixed travel distances of 5, 10, 15, 20, 25, 30, and 35 mm could be realized. The friction between the device and the track was found to be approximately 0.4N on average. It was dependent on position but it was always less than 0.6N. The effective mass of the device was 0.695 kg.

3.2.2 Sensors and Instrumentation

Force, position, velocity and acceleration data were recorded during the experiments. The applied force was measured by a BLH semiconductor strain gage mounted a fixed distance below the cylindrical roller (See Figure 3.2). The strain gage was part of a resistive bridge circuit whose buffered output was amplified through a low

noise NE5532 operational amplifier. Calibrating the strain gage was accomplished by applying standardized weights, through a pulley system, to the contact region on the roller. The relationship between the output signal of the amplifier and the applied force was determined through regression analysis. The results indicated that force/voltage relationship was highly linear with R^2 values typically greater than 0.998 and the standard error between estimated and actual force values was always less than 0.025N. During the operation of the Linear Grasper, the cascaded noise level of the force sensor and the A/D board was 0.2N.

The displacement of the finger plate assembly along the linear track was measured with a Sunflower floating linear differential transformer (FLDT). The FLDT was mounted from the non-moveable support frame of the motor to a rigid arm that extended out from the finger plate assembly. The signal conditioned output of FLDT had a specified full scale linearity of 0.10% over its range of travel of 40 mm. The sensor was calibrated by moving the finger plate assembly to series of fixed displacements (determined by placement of the mechanical stop) and measuring both the output signal of the FLDT and the actual position with a micrometer. The overall accuracy of the system including noise was approximately 0.12mm.

Velocities and accelerations were also recorded during the experiments. The velocity sensor was an inductive type sensor from Transducer Systems and was connected to the finger plate assembly in the same fashion as the FLDT. The output of the velocity sensor was signal conditioned with an Analog Devices AD620 instrumentation amplifier. Acceleration was measured with a $\pm 5g$ accelerometer from IC Sensors. The accelerometer was mounted directly below the strain gage on the finger plate assembly. The sensor's output was amplified with a Burr Brown INA105 instrumentation amplifier and filtered through an RC low pass filter with a 10Hz break frequency. The low pass filter was necessary to eliminate noise in the output signal that was created by spurious vibrations in the assembly as it traveled along the linear track.

The sensors were calibrated by applying a constant force to the moveable finger plate assembly. Initially, this was accomplished by attaching a hanging mass to the assembly through the same pulley system that was used to calibrate the force sensor. Later, after the motor's force/current relationship was established, the constant force was generated through a computer controlled drive signal to the motor. The application of force resulted in the motion of the finger plate assembly along the linear track. While the force was being applied, the displacement of the assembly and the velocity and acceleration signals were sampled at 1kHz. When the finger plate assembly had traveled 25mm, the force was no longer applied to the device and data acquisition was halted. The sampled data were then saved to a file.

This procedure was repeated for several different force values. Typical displacement data are shown in Figure 3.3. In the graph, data points representing the position of the finger plate assembly are plotted versus time for applied forces values of 2, 4, 6, and 8 Newtons. Best fit curves, in a least-squares sense, are shown as solid lines through the data points. It was found that the displacement data was well modeled by a second order polynomial equation of the form:

$$x(t) = k_2 t^2 + k_1 t + k_0 \quad (1)$$

where, $x(t)$, is the displacement of the finger plate assembly as a function of time, t , and k_2 , k_1 , k_0 are the constant coefficients of the polynomial expression. Typical values of k_2 , k_1 , k_0 , are given in Table 3-1 for different input forces. Note that the values of k_2 were typically several times greater than k_1 and k_0 ; thus $x(t)$ was basically a simple parabolic function. By differentiating Equation (1), expressions for velocity and acceleration could also be determined:

$$v(t) = \dot{x} = 2k_2 t + k_1 \quad (2)$$

$$a(t) = \ddot{x} = 2k_2 \quad (3)$$

where $v(t)$ and $a(t)$ represent the time functions of velocity and acceleration, respectively.

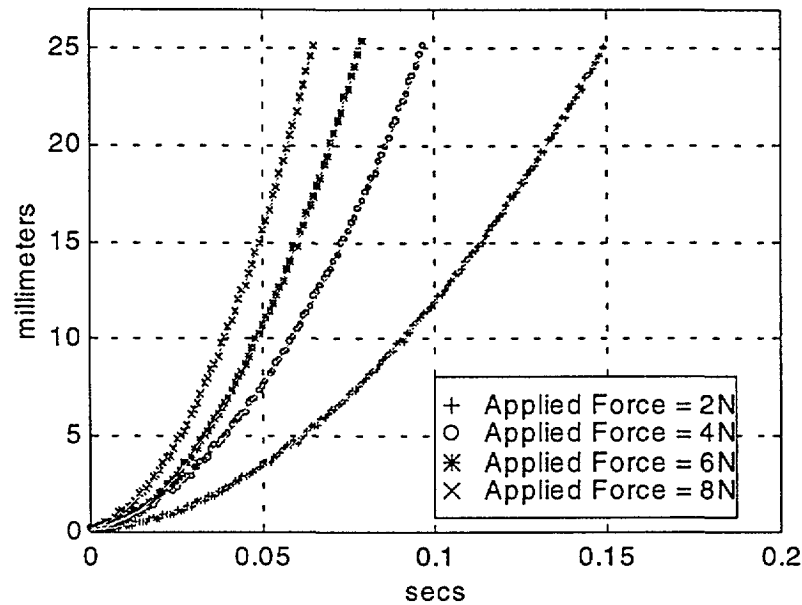

Figure 3.3: *Position versus time for different applied forces*

Equations (2) and (3) implied that a constant driving force would result in a constant acceleration of the finger plate assembly and a linearly increasing velocity of the device. This was consistent with the output recorded from acceleration and velocity sensors during the procedure. Using values of k_2 and k_1 both the accelerometer and the velocity sensor were calibrated through regression analysis. The overall accuracy of the sensors with noise was typically 15 mm/sec^2 for the accelerometer and was approximately 0.1 mm/sec for the velocity sensor.

Because the acceleration of the device, in the presence of a constant force, was constant, the device could be modeled as a mass with a known amount of friction. By subtracting out the frictional force component, the effective mass of the device could be calculated by dividing the net applied force to the device by the measured acceleration. Typical values of mass are presented in Table 3-1 for different input forces. An average value of 0.695 kg was used for the device's mass.

Applied Force	Friction	k_0	k_1	k_2	Mass
2.0 N	0.4 N	0.5 mm	42.9 mm/sec	1,144.4 mm/sec ²	0.703 kg
2.5 N	0.4 N	0.5 mm	49.2 mm/sec	1,504.0 mm/sec ²	0.700 kg
3.0 N	0.4 N	0.6 mm	78.5 mm/sec	1,884.9 mm/sec ²	0.692 kg
3.5 N	0.4 N	0.5 mm	85.7 mm/sec	2,282.0 mm/sec ²	0.681 kg
4.0 N	0.4 N	0.5 mm	104.6 mm/sec	2,621.3 mm/sec ²	0.689 kg

Table 3.1: Values of k_2 , k_1 , k_0 and mass for different applied forces.

3.2.3 Data Acquisition and Control System

The output signal of each sensor was sampled through a differential input channel of a Metrabyte DAS-1602 analog-to-digital (A/D) converter at 1kHz by an IBM compatible 80486DX 66MHz personal computer. The 12 bit A/D converter was configured for an analog input range of ± 10 volts with a resolution of 0.0049 volts/bit. This resulted in a the force signal resolution of ± 0.05 Newtons, a position signal resolution of ± 0.06 mm, a velocity signal's resolution of ± 0.05 mm/sec and an acceleration signal resolution of approximately ± 4.0 mm/sec². The specified maximum error of the A/D board was 0.2% of ± 1 least significant bit and thus had a negligible effect on the overall accuracy of the sensor readings.

Data acquisition and control during the experiments was performed by experiment specific software routines running on the IBM compatible 80486DX personal computer. The source code used for all the experiments is presented in Appendix A. With the exception of the control loop routine, all four types of discrimination experiments followed the same basic algorithm. A simplified block diagram of the algorithm is shown in Figure 3.4.

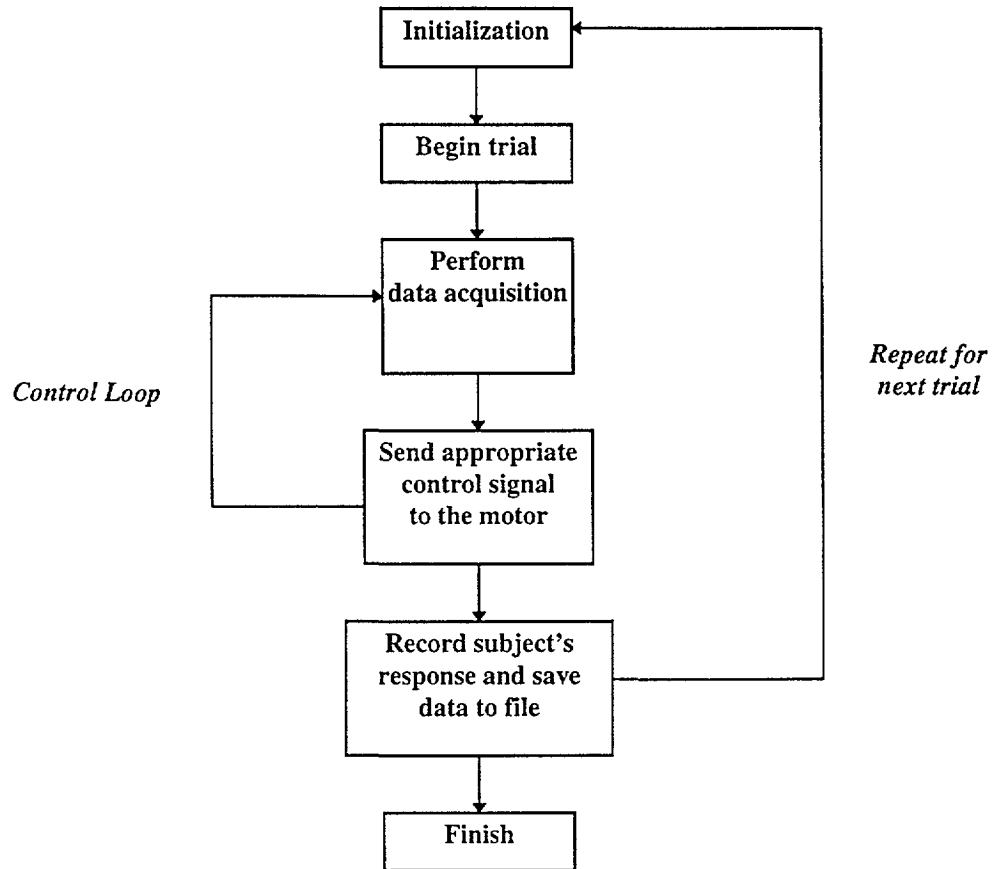

Figure 3.4: Block Diagram of the Basic Data Acquisition and Control Algorithm

The initialization routine ensured that the motor-finger assembly was at the designated starting location on the linear track before each trial. If the assembly was not in the correct position, the routine sent a drive signal to the motor until the desired starting position was reached. Additionally, this part of the program was used to measure and compensate for any DC offsets present in the force, velocity and acceleration signals. The routine also determined the stimuli presentation order for the experiment and prompted the subjects with a text message on the computer monitor when the experiment was ready to begin.

All discrimination experiments involved the presentation of a specific stimulus for a fixed displacement. The value of the fixed displacement was determined before the experiment was started. (The experimental protocol followed in the discrimination

experiments is explained in greater detail in Chapter 4.) To accurately present the discrimination stimuli to the subjects over this fixed displacement, two different control algorithms were developed. One algorithm was designed for the viscosity and mass discrimination experiments and the other one was developed for the velocity and acceleration discrimination experiments. The algorithms are described separately:

Viscosity and Mass Simulation Algorithm

Viscosity and mass stimuli were simulated through an *impedance control* algorithm. During the experimental trial, the velocity or acceleration of the device was sampled at 1kHz and a desired output force was calculated by multiplying the sampled velocity or acceleration by the damping factor, B , or mass, M , that was being simulated ($F=BV$ or $F=MA$). The value of the output force was adjusted to compensate for the average friction along the track and for any inertial force that was created by the acceleration of the motor-finger interface's mass. An appropriate control signal was then determined and sent through a digital-to-analog converter and a voltage-controlled current source to the actuator (The motor control hardware are presented in Section 3.2.4). The resulting resisting force of the motor was thus proportional to velocity in the viscosity discrimination experiments and acceleration in the mass discrimination experiments. The differences between desired and simulated mass and viscosity values were always less $\pm 2.0\%$.

Velocity and Acceleration Control Algorithm

In the velocity and acceleration discrimination experiments, the goal was to present subjects with a constant velocity or acceleration stimulus over a fixed displacement. To accomplish this, a digital control system with proportional feedback and disturbance rejection was developed. A discrete representation of the feedback system is shown in Figure 3.5. The first step in designing the control system was to determine the discrete transfer function of the plant. For a plant, $G(s)$, preceded by a zero-order hold, the discrete transfer function is defined as $(1 - z^{-1})Z\{G(s)/s\}$ (Kuo).

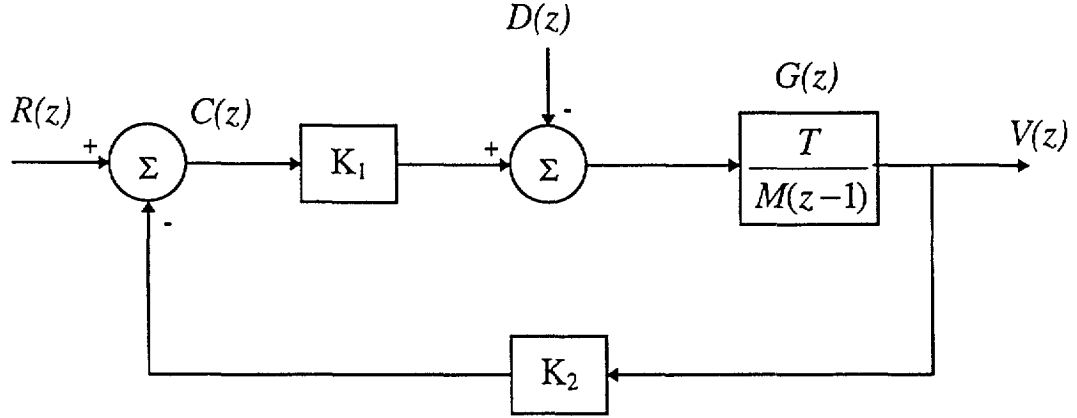

Figure 3.5: Discrete Realization of the Feedback Control System

The plant in this system is a mass, therefore,

$$G(z) = \left(\frac{z-1}{z}\right)Z\left\{\frac{1}{s^2 M}\right\} = \left(\frac{z-1}{z}\right)(Tz \frac{1}{M(z-1)^2})$$

thus,

$$G(z) = \frac{T}{M(z-1)}$$

where T is the time of the length of the zero order hold and M is the mass of the device (0.695 kg). Using this, the z-transform of the discretized velocity of the device is:

$$V(z) = \frac{[K_1 R(z) - D(z)](T/M)}{z - (1 - K_1 K_2 T/M)}$$

where $R(z)$ is the z-transform of reference signal, $C(z)$ is the z-transform of the control signal and $D(z)$ is the z-transform of a disturbance input to the system. (Examples of possible disturbances to the system include changes in friction along the track or resistance from the subject's thumb.) K_1 and K_2 represented the feedforward and feedback gain of the controller, respectively. With $D(z) = 0$, then a step input, $r(kT) = U(kT)$ results in a discrete velocity,

$$v(kT) = \frac{1}{K_1} U(kT) - \frac{1}{K_1} \left(1 - \frac{K_1 K_2 T}{M}\right)^k U(kT)$$

Thus a step input in the reference signal will result in a step change in the steady-state velocity, provided the following stability design constraint is met:

$$\left| 1 - \frac{K_1 K_2 T}{M} \right| < 1$$

Since $M = 0.695\text{kg}$, $T = 0.001\text{sec}$, and $K_1, K_2 > 0$, then the design constraint becomes:

$$K_1 K_2 < 1390$$

Another design goal is to minimize the influence of a disturbance on velocity. This is accomplished by making the feedforward gain, K_f , as large as practically possible, since the net input to the system is:

$$K_f C(Z) - D(Z)$$

Through trial and error, gains of $K_f = 7.0$ and $K_2 = 50.0$ were chosen for the control system. These gain settings provided adequate rejection of disturbances to the system while still ensuring a robustly stable controller. Overall, the system would reach 98% of steady state velocity within seven sampling periods (0.007millisec) and the standard deviation in desired velocity over the fixed displacement was less than 3%. Typical results for a control velocity of 85 mm/sec are shown in Figure 3.6. Noticeably larger gains, especially for K_f , would result in small vibrations of the mechanical arm that connected the velocity sensor to the moving finger plate assembly. This in turn would lead to a marginally stable mechanical chattering of the finger plate assembly. Acceleration control was accomplished with the same control loop, but a ramp input to the system, $r(kt) = kT U(kT)$, was utilized instead of a step input.

For all experiments, once the position of the finger plate traveled beyond a specified displacement the control algorithm was terminated. The remaining portion of the software program was responsible for prompting the subject for an allowable response, recording the response (entered via keyboard input), and returning the finger plate to the starting position for the next trial. At the completion of the last trial in an experimental

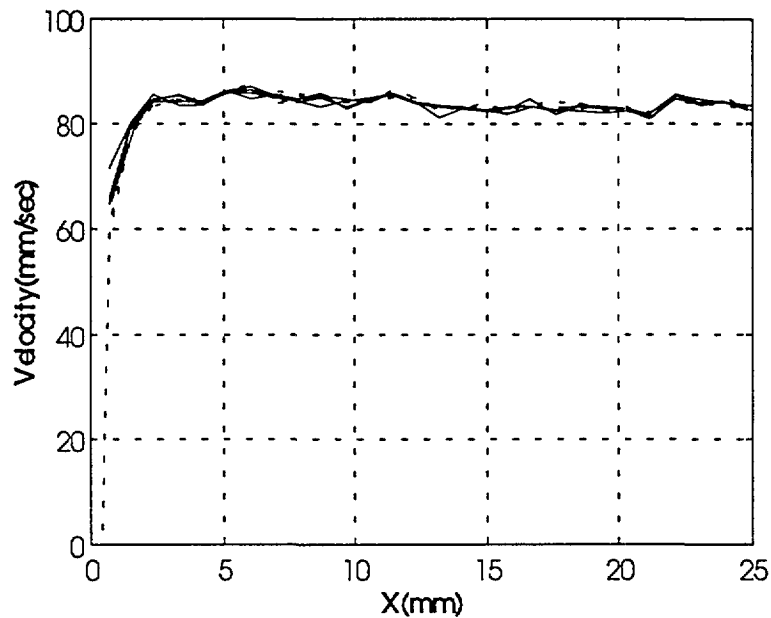

Figure 3.6: *Typical Velocity Plots versus Displacement*

trial, run, the pertinent psychophysical data, consisting primarily of the stimulus and response for each were written to an ASCII text file for later analysis. Additionally, the force, position, velocity and acceleration data recorded for each trial were written to a different file in a binary format that facilitated later analysis with Matlab.

3.2.4 Motor Control Hardware

The control signal was supplied to the actuator mechanism of the Linear Grasper through a Metrabyte digital-to-analog converter (DAC) and a Techron DC power amplifier. The 12-bit DAC had a ± 10 volt output range and a resolution of 4.9 millivolts/bit. The power amplifier acted as a voltage controlled current source with the current output of the amplifier used to directly control the force generated by the motor. The force/current relationship of the device was determined with the same apparatus utilized to calibrate the force sensor. The relationship was linear and constant over the entire 40 mm stroke range of the piston. The calibrated control signal had a resulting resolution of ± 0.04 N.

4

Method

4.1 Introduction

The general psychophysical method employed to measure human resolution in discriminating viscosity, mass, velocity and acceleration was the *one-interval, two alternative forced choice* (1I-2AFC) paradigm with correct response feedback. The paradigm's theoretical foundation, metrics, and practical application are well described elsewhere (Durlach, 1968; Macmillan, 1991; Geschieder, 1985). A summary of the method taken from notes by Durlach (1968) is presented in Appendix A.

Provided below is a description of the general procedure used in the viscosity and mass discrimination experiments along with the details of the two different types of viscosity and mass discrimination experiments that were carried out. Afterwards, a section describing the method used in velocity and acceleration discrimination experiments is presented.

4.2 Viscosity and Mass Discrimination Experiments: General Method

4.2.1 Apparatus

The Linear Grasper was used for all viscosity and mass discrimination experiments. During each experimental trial, the subject interacted with the apparatus by squeezing two parallel aluminum plates with the thumb and forefinger. This action would result in the

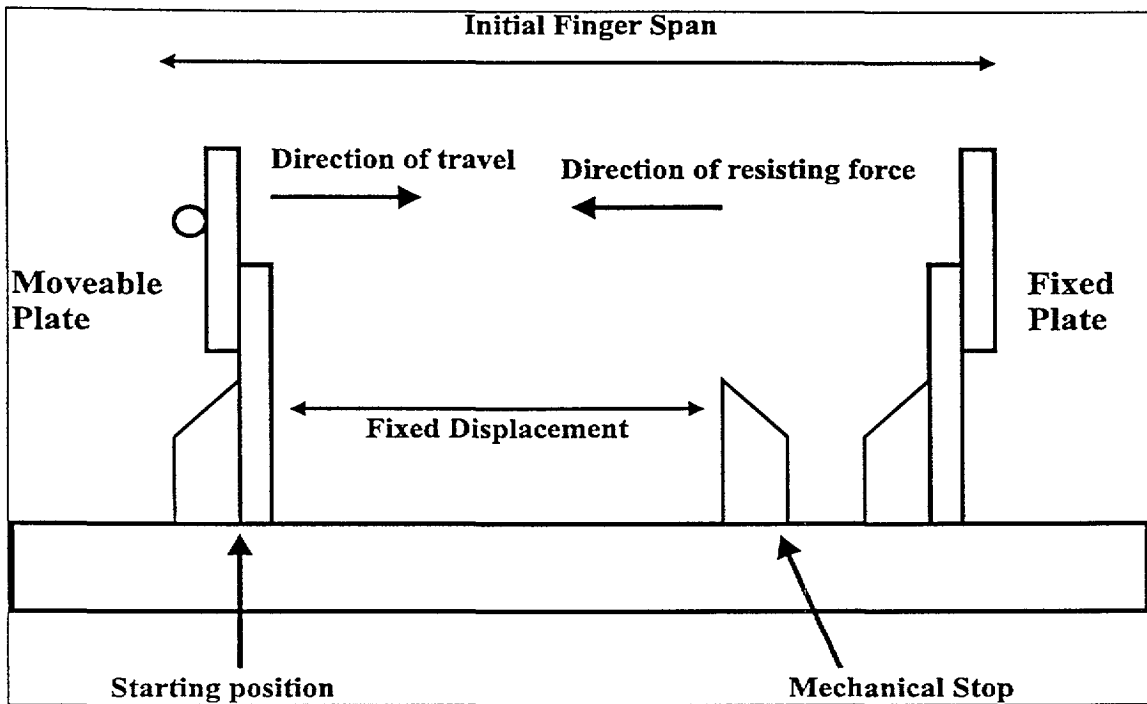

Figure 4-1: The Layout of the Linear Grasper during an Experimental Trial

movement of one of the plates along a linear track towards the other plate whose position was fixed. In response to this active finger motion, the Linear Grasper was programmed to produce a resisting force proportional to velocity in the viscosity discrimination experiments and acceleration in the mass discrimination experiments. The resisting force was removed when the moveable plate pushed by the thumb came into contact with a mechanical stop placed at a fixed distance along the linear track. To minimize any vibrations due to impact, thin foam pads were placed on the mechanical stop. A diagram illustrating the process is shown in Figure 4-1. Once the subject entered a response into the computer, the moveable plate was returned to its starting position for the next trial.

A cylindrical roller mounted on the moveable plate served as the contact point for the thumb so that measurements from the strain gage mounted at the bottom of the plate could be accurately converted to force values. The cylindrical roller also ensured that the pushing force applied by the thumb was always perpendicular to the moveable plate. In addition to the applied force, the position, velocity and acceleration of the moveable plate were also measured during the experiment. While these measurements were sampled at

1kHz for control purposes, to create manageable sized data records, the data was saved to a file at 200 Hz.

4.2.2 Subjects

A total of twelve subjects participated in the viscosity and mass discrimination experiments. The group consisted of six males and six females, ages 18 - 26 years old. Six of the subjects also participated in the velocity and acceleration discrimination experiments. The subjects were either undergraduate or graduate students at MIT and were paid on an hourly basis. All subjects were right handed, with no known hand disorders and used their right hand for all experiments.

4.2.3 Procedure

The experiments used the one-interval, two-alternative forced choice paradigm. Because subjects were asked to discriminate viscosity or mass, it was possible that their interpretation of the instructions might differ. In order to minimize such differences, trial-by-trial correct response feedback was given to the subjects. During a trial, subjects were randomly presented with one of two possible stimuli. One of the stimuli was the *reference* (e.g., B_0) and the other was the *comparison*, equal to the reference minus an increment (e.g., $B_0 - \Delta B$). The value of the increment was constant within an experimental run of 64 trials. For each trial, both stimuli had an equal *a priori* probability of occurring. Upon completion of a trial, the subjects were required to indicate which one of the two stimuli they felt was presented by typing 1 for the larger stimuli or 2 for the smaller stimuli. After the selection was made for each trial, the subjects were provided with correct response feedback.

4.2.4 Data Analysis

A 2x2 stimulus-response matrix generated from each experimental run was utilized to compute a sensitivity index, d' , and a response bias, β (See Appendix A for a more detailed presentation of the psychophysical method). The sensitivity indices from the experimental runs were used to calculate a commonly accepted measure of sensory

resolution, the Just Noticeable Difference (JND) for the subjects. The response bias data was used to determine if subjects were inclined towards selecting a particular response regardless of which stimulus was presented.

The recorded applied force and motional data sampled during each experiment were studied with a range of analytical tools and software routines developed within the computational support environment of Matlab. The algorithms of the more important analytical and graphical routines are presented in Appendix D.

4.2.5 Experiments with Different Fixed Displacements

The first set of viscosity and mass discrimination experiments were performed for fixed squeezing distances of 15, 20, 25, 30 and 35 mm. Six subjects took part in these experiments. Subjects *LR*, *BS*, and *BR* participated in the viscosity discrimination experiments and subjects *CK*, *BM*, and *BS* took part in the mass discrimination experiments. Before any experiments were initiated, the experimental procedure was verbally described and demonstrated to each subject. Afterwards, each subject underwent a training period of 1024 trials (16 experimental runs) to ensure that they were comfortable with the device and the procedure.

For both experiments, the initial finger span between the thumb and forefinger of the subjects was set at 105 mm. In each experimental run of 64 trials, the squeezing distance was kept constant at one of the five fixed displacement values. The fixed displacement and initial finger span parameters were chosen so that the viscosity and mass discrimination results would be collected over the same range of values that were used in the force (Pang et al, 1989) and compliance discrimination experiments (Tan et al, 1995).

Based on preliminary experiments, a reference viscosity, B_o , of 120Ns/m was presented in the viscosity discrimination experiments and a reference mass, M_o , of 12 kg was presented in the mass discrimination experiments. These values were chosen to ensure that applied grasp forces would be generally consistent with those used in the earlier force and compliance discrimination experiments. The stimulus increment in the viscosity discrimination experiments (ΔB) was equal to either 10, 20, or 30% of the

reference viscosity and in the mass discrimination experiments, the stimulus increment (ΔM) was equal to 10, 20, 30, or 40% of the reference mass. Thus there were a total of fifteen experimental conditions (three $\Delta B/B_0$ values for each of five fixed displacements) for the viscosity experiments and twenty experimental conditions (four $\Delta M/M_0$ values for each of five fixed displacements) for the mass experiments. Since for each value of the stimulus increment, numerous experimental runs were performed, subjects typically completed greater than 3000 trials. It took approximately six weeks to complete the experiments.

4.2.6 Experiments with Different Reference Values

To determine if Weber's Law was applicable to the discrimination of viscosity and mass through active grasping, discrimination experiments were carried out at different viscosity and mass reference values. Reference viscosities of 60Ns/m, 120Ns/m, and 180Ns/m were used in the viscosity discrimination experiments and reference masses of 6.0kg, 9.0kg, and 12.0kg were utilized in the mass discrimination experiments. Subjects *JY*, *DH* and *ZS* took part in the viscosity discrimination experiments and subjects *JN*, *AM*, and *BM* engaged in the mass discrimination experiments. As with the fixed displacement experiments, the experimental procedure was described and demonstrated to each subject before starting and each subject also underwent a training period of 1024 trials.

A fixed squeezing distance of 25 mm was used for all reference values. To be consistent with the fixed displacement experiments, the initial finger span between the thumb and forefinger of the subjects was set at 105 mm. These experimental conditions allowed direct comparison of the results at 12kg and 120Ns/m for both sets of experiments.

The stimulus increment in the viscosity discrimination experiments (ΔB) was equal to either 10, 15, 20 or 25% of the reference viscosity and in the mass discrimination experiments, the stimulus increment (ΔM) was equal to 10, 20, 30, or 40% of the reference mass. Thus, there were a total of twelve experimental conditions (four $\Delta B/B_0$

values for each of three reference viscosities) for the viscosity experiments and twenty experimental conditions (four $\Delta M/M_0$ values for each of three reference masses) for the mass experiments. All subjects completed more than 3000 trials (not including training). The experiments took approximately one month to complete.

4.3 Velocity and Acceleration Discrimination Experiments

4.3.1 Apparatus

The Linear Grasper was also utilized for all the velocity and acceleration discrimination experiments. The experiments involved passive discrimination and therefore did not require any motor activity on the part of the subject (such as grasping the two parallel aluminum plates). As a result the apparatus had to be slightly modified. The cylindrical roller, that served as the point of contact for the subject's thumb in the viscosity discrimination and mass discrimination experiments, was replaced with a molded thumb support attached to the moveable plate. An appropriately sized support was fabricated for each subject from a hard plastic finger splint and was lined with foam padding to produce a snug support for the thumb. The support was mounted to the moveable plate so that the surface of the subjects' thumb pad, when it was in the support, was nearly parallel to the plate. The support ensured that the subject's thumb remained in contact with the moveable plate during the experiment.

Before starting an experiment, the subject would first place the forefinger flush against the fixed plate and then place the thumb in the support so that the hand would be in a pinch grasp position comparable to what was used in the viscosity and mass discrimination experiments. To initiate a trial, the subject would hit the space bar on the keyboard. After a short delay, the Linear Grasper was programmed to drive the moveable plate (and thus the thumb of the subject) at a constant velocity in the velocity discrimination experiments or with a constant acceleration in acceleration discrimination experiments. After the moveable plate traveled a predetermined fixed displacement, the signal used to control the velocity or acceleration of the Linear Grasper was removed,

after which the moveable plate decelerated to a stop after a short distance. To avoid the possibility of impact cues, a mechanical stop was not used to stop the motion of the plate. Once the subject entered a response, the moveable plate was returned to the starting position for the next trial.

It is important to note that if the subject applied a resisting or pushing force greater than 1 Newton, the experiment would immediately stop and the data would not be used. This was done to ensure that the subject did not apply a grasping force or impedance to the plate that would result in a significantly erroneous velocity or acceleration stimulus. It was also implemented as a safety precaution in case the subject's thumb was somehow caught in the support.

4.3.2 Subjects

The six subjects who participated in the viscosity and mass discrimination experiments at different references also took part in velocity and acceleration discrimination experiments. Specifically, subjects *JY*, *DH* and *ZS* engaged in the velocity discrimination experiments and subjects *JN*, *AM*, and *BM* participated in the acceleration discrimination experiments. The subjects did not start the experiments until they had completely finished the viscosity and mass discrimination experiments. The experimental procedure was described and demonstrated to each subject before starting. Each subject also underwent a training period of 500 trials to familiarize themselves with the experiment and the apparatus.

4.3.3 Procedure

The experiments used the one-interval, two alternative forced choice paradigm with correct response feedback. One of the stimuli was the *reference* (e.g., V_0) and the other was the *comparison*, equal to the reference minus an increment (e.g., $V_0 - \Delta V$). The value of the increment was constant within an experimental run of 50 trials. For each trial, both stimuli had an equal *a priori* probability of occurring. Upon completion of a trial, the subjects were required to indicate which one of the two stimuli they felt was presented by

typing 1 for the larger stimuli or 2 for the smaller stimuli. After the selection was made for each trial, the subjects were provided with correct response feedback.

4.3.4 Data Analysis

Similar to the viscosity discrimination and mass discrimination experiments, A 2x2 stimulus-response matrix generated from each experimental run was utilized to compute a sensitivity index, d' , and a response bias, β (See Appendix A for a more detailed presentation of the psychophysical method). The sensitivity indices from the experimental runs were used to calculate the Just Noticeable Difference (JND) for the subjects. The response bias data was used to determine if subjects were inclined towards selecting a particular response regardless of which stimulus was presented.

4.3.5 Experimental Parameters

For both experiments, JNDs were measured for a series of reference values. In the velocity discrimination experiments, reference velocities of 60mm/sec, 80mm/sec, 100mm/sec and 120mm/sec were used. In the acceleration discrimination experiments, reference accelerations of 400mm/sec², 800mm/sec², 1200mm/sec², and 1600mm/sec² were used. The reference values were chosen such that the velocity stimuli were over the same range of velocities recorded during the viscosity discrimination experiments and acceleration stimuli were over the same range of accelerations recorded in mass discrimination experiments. Also consistent with the viscosity and mass discrimination experiments, the stimuli were presented over a fixed displacement of 25mm and the initial finger span of the subjects was 105mm.

The stimulus increment in the velocity discrimination experiments (ΔV) was equal to either 10, 15, 20% of the reference velocity and in the acceleration discrimination experiments, the stimulus increment (ΔA) was equal to 20, 30, or 40% of the reference acceleration. Thus, there were a total of twelve experimental conditions (three $\Delta V/V_0$ values for each of four reference velocities) for the velocity discrimination experiments and twelve experimental conditions (three $\Delta A/A_0$ values for each of three reference

accelerations) for the mass experiments. The experiments took approximately one month to complete.

5

Viscosity Discrimination Results

5.1 Just Noticeable Difference

5.1.1 Fixed Displacement Results

The JND results for the fixed displacement viscosity discrimination experiments are plotted with respect to the various fixed squeezing distances in Figure 5.1. Each subject completed a total of 3,840 trials. The average JND over the five fixed displacements of 15, 20, 25, 30, and 35 mm was 14.2%. The standard deviation was 1.1% indicating that the JNDs were relatively constant with respect to squeezing distance. JND data for the individual subjects are presented in Table 5.1. The standard deviation in the JND among the subjects was 3.2%. This was largely due to the difference between the performance of subject LZ (average JND of 18.7%) and the other two subjects (average JNDs of 12.0% and 11.7%). The β values presented in Table 5.2, are generally small for the experiments indicating that the subjects were unbiased in their responses.

Subject	15mm JND	20mm JND	25mm JND	30mm JND	35mm JND	Average JND
BR	13.6%	15.0%	12.5%	9.2%	9.8%	12.0%
BS	10.9%	12.5%	12.4%	14.0%	8.9%	11.7%
LR	21.9%	18.7%	15.3%	18.8%	19.7%	18.7%
Average	15.5%	15.4%	13.4%	13.8%	12.8%	14.2%

Table 5.1: *JND Results for the Fixed Displacement Discrimination Experiments*

Subject	15mm β	20mm β	25mm β	30mm β	35mm β	Average β
BR	0.24	0.39	0.33	0.16	0.26	0.28
BS	-0.07	0.11	-0.03	0.12	0.11	0.05
LR	0.00	-0.05	-0.03	0.16	-0.01	0.01
Average	0.06	0.15	0.09	0.15	0.12	0.11

Table 5.2: Bias Results for the Fixed Displacement Discrimination Experiments

5.1.2 Different Reference Results

The JND results for different reference viscosities are presented in Figure 5.2. Each subject completed a total of 3,072 trials for the three reference values of 60, 120, and 180 Ns/m. The average JND for all references was 9.5% with a standard deviation of 1.9% between references. The results are reasonably consistent with Weber's law. The average subject JNDs ranged from a low of 7.3% for subject JY to a high of 11.4% for subject DH. The standard deviation among the subjects was 1.7%. Individual subject results for JND and bias are presented in Tables 5.3 and 5.4, respectively. Consistent with the bias results from the fixed displacement experiments, subjects did not appear to show a strong predilection towards selecting a particular response.

Subject	60Ns/m JND	120Ns/m JND	180Ns/m JND	Average JND
JY	6.8%	7.7%	7.3%	7.3%
ZS	9.8%	10.0%	9.6%	9.8%
DH	12.1%	12.6%	9.6%	11.4%
Average	9.6%	10.1%	8.8%	9.5%

Table 5.3: JND Results for the Different References

Subject	60Ns/m β	120Ns/m β	180Ns/m β	Average β
JY	0.03	0.05	0.21	0.10
ZS	-0.09	-0.11	0.04	-0.05
DH	0.05	0.00	0.09	0.05
Average	0.00	-0.02	0.11	0.03

Table 5.4: Bias Results for the Different References

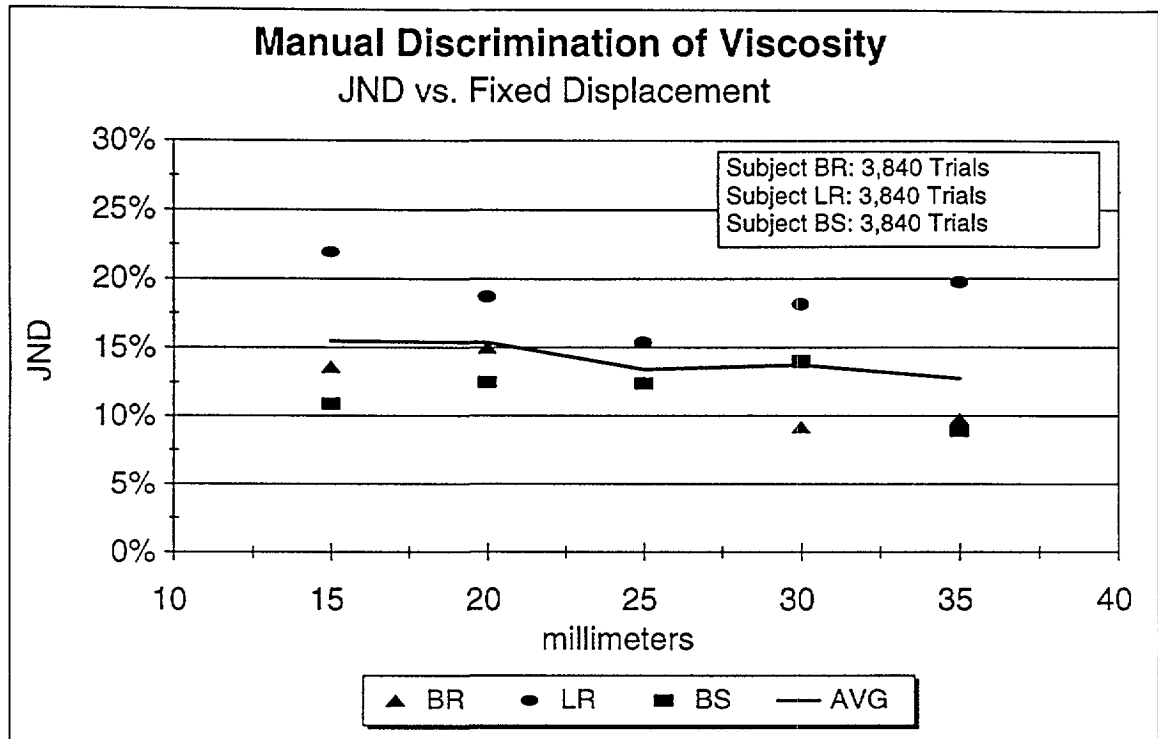

Figure 5.1: Viscosity JND vs Fixed Displacement

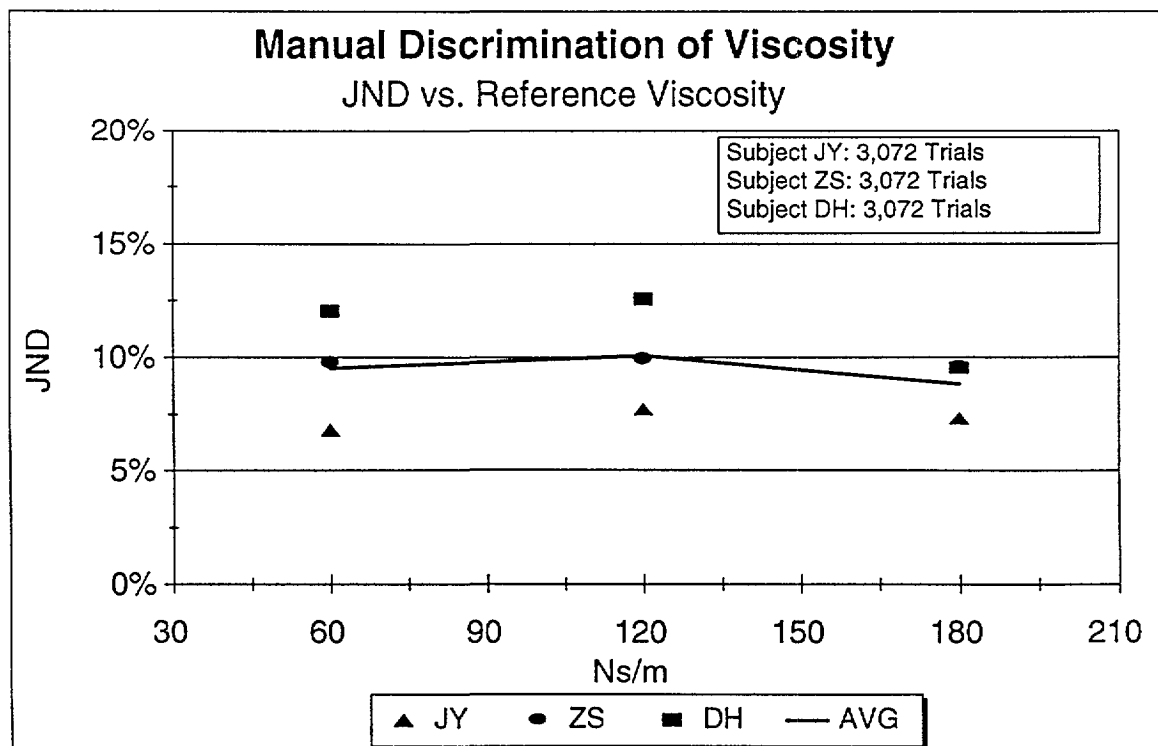

Figure 5.2: Viscosity JND vs. Reference

5.1.3 Overall Results

The average mean JND for subjects of both experiments was 11.8% with an overall standard deviation of 4.0%. The average JND for the subjects in the fixed displacement experiments was somewhat higher than that for the subjects in the experiment with different references (14.2% versus 9.5%). The mean JND values for the subjects ranged from a low of 7.3% for subject JY to a high of 18.7% for subject LZ. The standard deviation of all subject JNDs was 3.5%.

5.1.4 Anecdotal Subject Observations

At the completion of the experiments, the subjects were asked to articulate what strategies or methods they utilized in the discrimination process. Typically, most subjects stated that they discriminated on the basis of perceived differences in the “resistance” or “resisting force” of the viscosity stimuli. Some subjects felt that they discriminated on the basis of a perceived “viscous force”. Furthermore, when their performance was optimal, the subjects generally felt that they could readily perceive a difference in the “resistance” of the stimuli during the initial grasping motion and did not require the full squeezing distance to make a decision. Although subjects were not directly asked to describe the motor activity they used in the task, some subjects stated that they felt that they had employed a natural grasping or pinching action during the experiments.

5.2 Motor Performance

Whereas motor performance data were recorded during both sets of experiments, a significantly larger amount of data was recorded for the discrimination experiments involving different reference viscosities. Specifically, in the fixed displacement experiments, motor performance data were sampled during 400 trials, whereas in the different reference discrimination experiments, data were recorded for all 9,216 trials. Because few trials were recorded in the fixed displacement experiments, motor performance results for these experiments will be limited to plots of typical applied force and velocity data, some general observations about the data, and a presentation of average force and motional data. A more comprehensive presentation of motor performance data is given for the discrimination experiments involving the different reference viscosities.

5.2.1 Fixed Displacement Experiments

In the fixed displacement discrimination experiments, results for subjects BS, LR, and BR were from data sampled on every fourth trial over the course of 576, 576, and 448 trials respectively. The trials were performed towards the end of the fixed displacement experiments. Data sampling for a particular trial was initiated once the moveable plate had been squeezed more than 1.0 mm by the subject. Typical plots of the subjects' force and velocity versus time and force and velocity versus displacement for the same trial are shown in Figures 5.3 - 5.8.

An analysis of plots of the subjects' applied force as a function of time indicated that there were some similarities in the shape of the force profiles for the three subjects. Primarily, the applied force traces could be divided into three segments: (1) an initial force ramp, (2) a period of constant force application, followed by (3) a decreasing force profile towards the end of the trial. Although, as is evident in Figures 5.3 - 5.8, the magnitude of the applied force and time lengths of the segments varied greatly among the subjects.

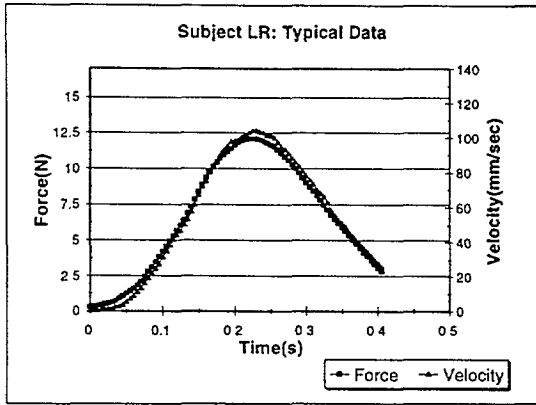

Figure 5.3: Typical Force and Velocity Data versus Time for Subject LR

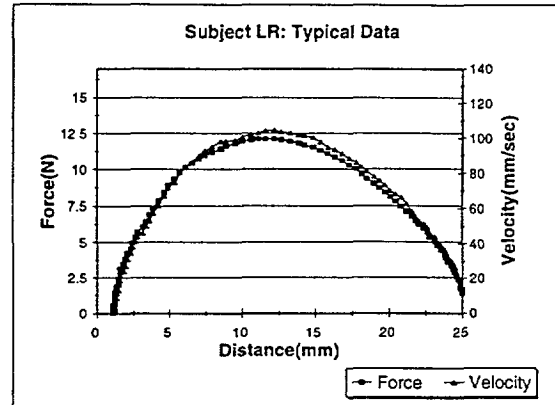

Figure 5.4: Typical Force and Velocity Data versus Squeezing Distance for Subject LR

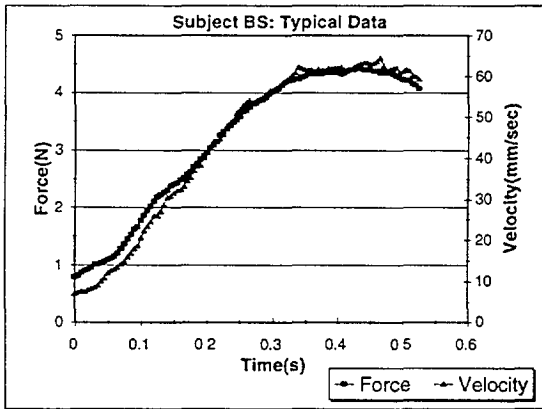

Figure 5.5: Typical Force and Velocity Data versus Time for Subject BS

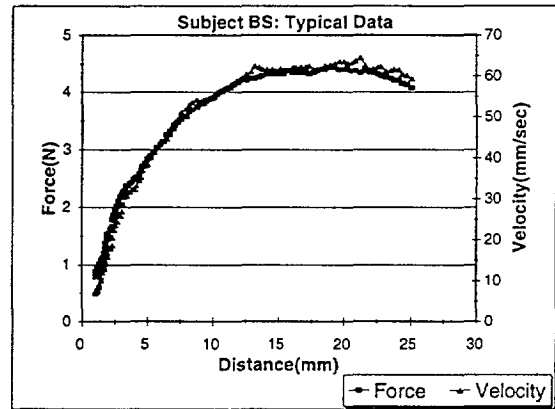

Figure 5.6: Typical Force and Velocity Data versus Squeezing Distance for Subject BS

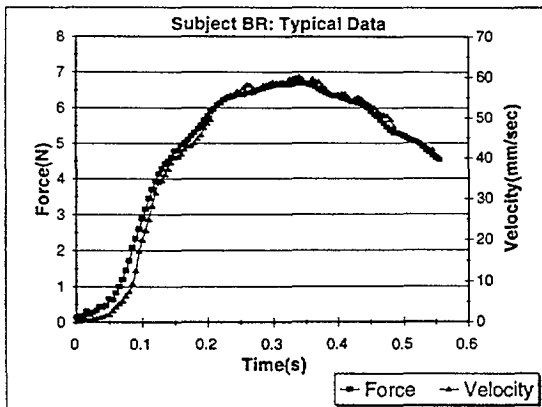

Figure 5.7: Typical Force and Velocity Data versus Time for Subject BR

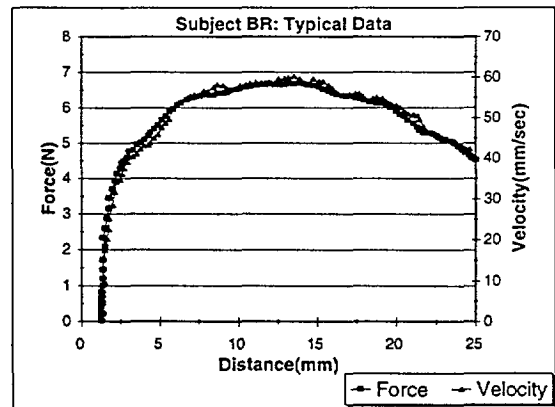

Figure 5.8: Typical Force and Velocity Data versus Squeezing Distance for Subject BR

A compilation of the average motor performance data are shown in Table 5.5. Presented in the table are the average mean forces applied for the reference and comparison stimuli and the corresponding average mean velocities for the two stimuli. The data is organized by subject and stimulus pair. For each stimulus, the values were calculated by computing a mean force and velocity for each trial involving that stimulus and then computing an average over all the trials.

The data indicates that the average force and velocity varied greatly among the subjects. Mean forces varied from approximately 3.6 to 9.6 Newtons and velocities from 35 mm/s to 95 mm/s. Despite this, there are some similarities in the subjects' motor performance: (1) The difference in the average mean force for the reference and comparison stimuli increases as the difference in the stimuli pair increases, (2) Likewise, a similar relationship is observed for the velocity data and (3) The average mean reference velocity is less than the corresponding velocity for the comparison for all stimulus pairs.

Subject	$\Delta B/B$	Average Mean Force for the Reference	Average Mean Force for the Comparison	Average Mean Velocity for the Reference	Average Mean Velocity for the Comparison
BS	30%	4.23N	3.55N	35.0 mm/s	42.3 mm/s
	20%	4.30	3.94	35.8	41.0
	10%	4.30	4.06	35.8	37.5
LR	30%	9.60N	7.85N	79.9 mm/s	93.4 mm/s
	20%	9.60	8.72	80.1	90.9
	10%	9.30	9.52	77.4	88.1
BR	30%	6.15N	5.03N	51.3 mm/s	59.9 mm/s
	20%	7.75	7.43	64.5	77.3
	10%	7.00	6.64	58.3	61.5

Table 5.5: Force and Velocity Data During the Fixed Displacement Experiments

Summary data plots for the overall averages of these variables are shown in Figures 5.9 and 5.10. In these plots, the force and velocity data, averaged over all subjects, are plotted against the viscosity stimulus values with error bars indicating standard deviation. These results show that mean force ranged from about 5.5 to 7 N in

the experiments. In addition, the average value of the mean applied force in each trial increased with the stimulus intensity, but with a decreasing gradient. In contrast, average mean velocity values (ranging from 55 mm/s to 70 mm/s) generally decreased with stimulus intensity.

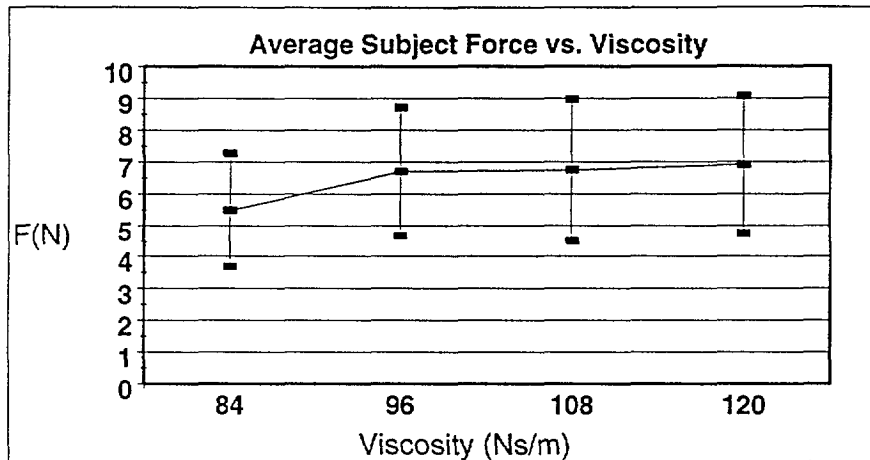

Figure 5.9: Average Force \pm one STD used by all Subjects in the Fixed Discrimination Experiments

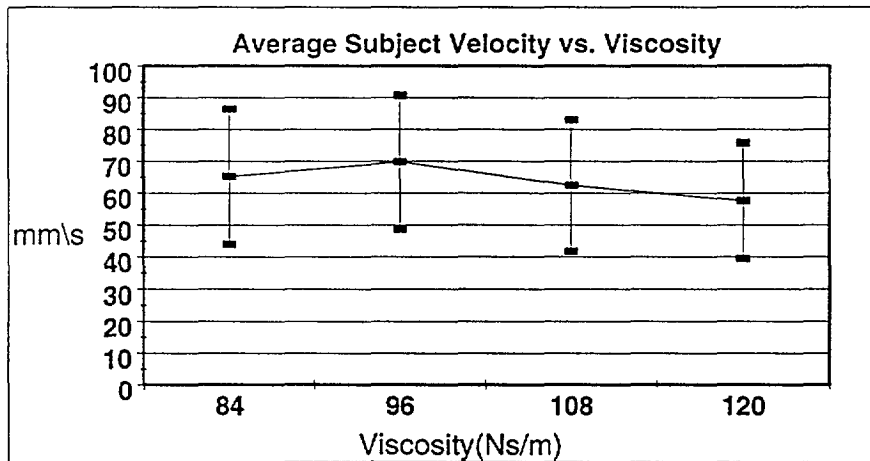

Figure 5.10: Average Velocity \pm one STD used by all Subjects in the Fixed Discrimination Experiments

5.2.2 Experiments with Different Reference Viscosities

In the viscosity discrimination experiments with different references, motor performance data for each subject was recorded for all trials. Since 3,072 trials were

performed by each subject, motor performance data consisting of applied force, position, velocity and acceleration data was recorded for a total of 9,216 trials. Data sampling was immediately initiated once the moveable plate was at the designated start position. Because of the large amount of data that was recorded, the force and motional results are presented in separate subsections. Each subsection presents typical raw data and computed overall average results. Additional plots of force and motional data can be found in Appendix B.

5.2.2.1 Force Data

Typical plots of force are shown in Figures 5.11 and 5.12. Each figure consists of six separate plots, two for each subject. Each plot consists of data from an entire experimental run. In Figure 5.11, force data are plotted versus time while in Figure 5.12, the same data are plotted versus squeezing distance. For all plots, the reference viscosity is 120Ns/m. Plots on the left side of each figure are from experiments when the difference between the reference and comparison stimuli was 10%, whereas graphs on the right are from experiments when the difference was 20%. For each plot, there are 64 force traces, one for each trial of an experimental run. Dotted line force traces indicate those trials when the reference viscosity was the stimulus while solid lines indicate when the comparison was the stimulus.

For each subject, the figures indicate that the basic shape of the temporal and spatial force profiles are generally similar during an experimental run, although there is variability in the amount of force that is applied on a given trial and in the delay before the subject begins to apply force to the plate. The time plots indicate that a trial typically took approximately 0.3 or less seconds to complete. In terms of squeezing distance, JY and ZS usually reached maximum applied force values within 10–15 mm of travel of the plate, similar to the performance of the subjects in the fixed displacement experiments (Figures

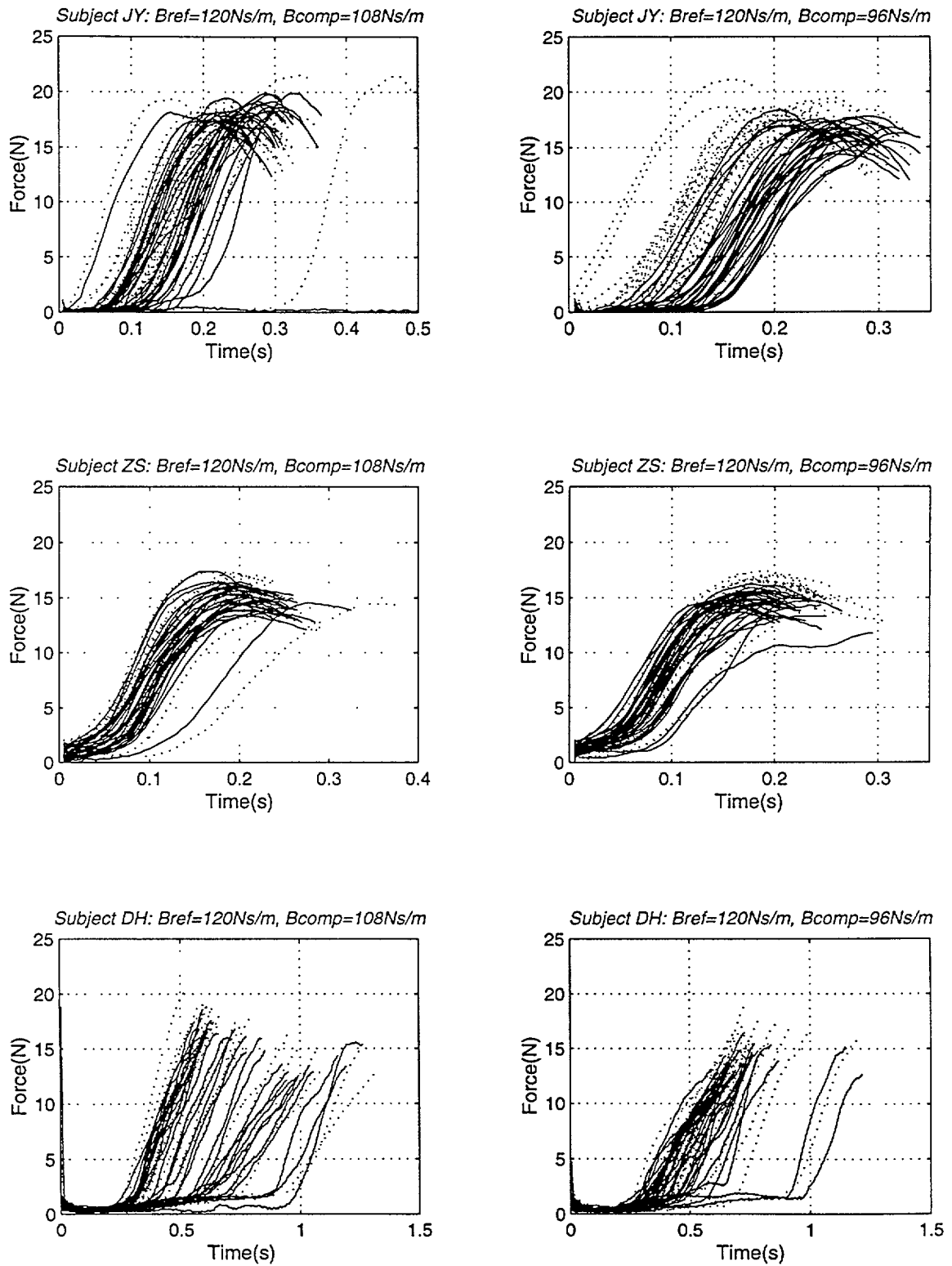

Figure 5.11: Applied Force versus Time Plots for $\Delta B/B_0 = 10\%$, $\Delta B/B_0 = 20\%$

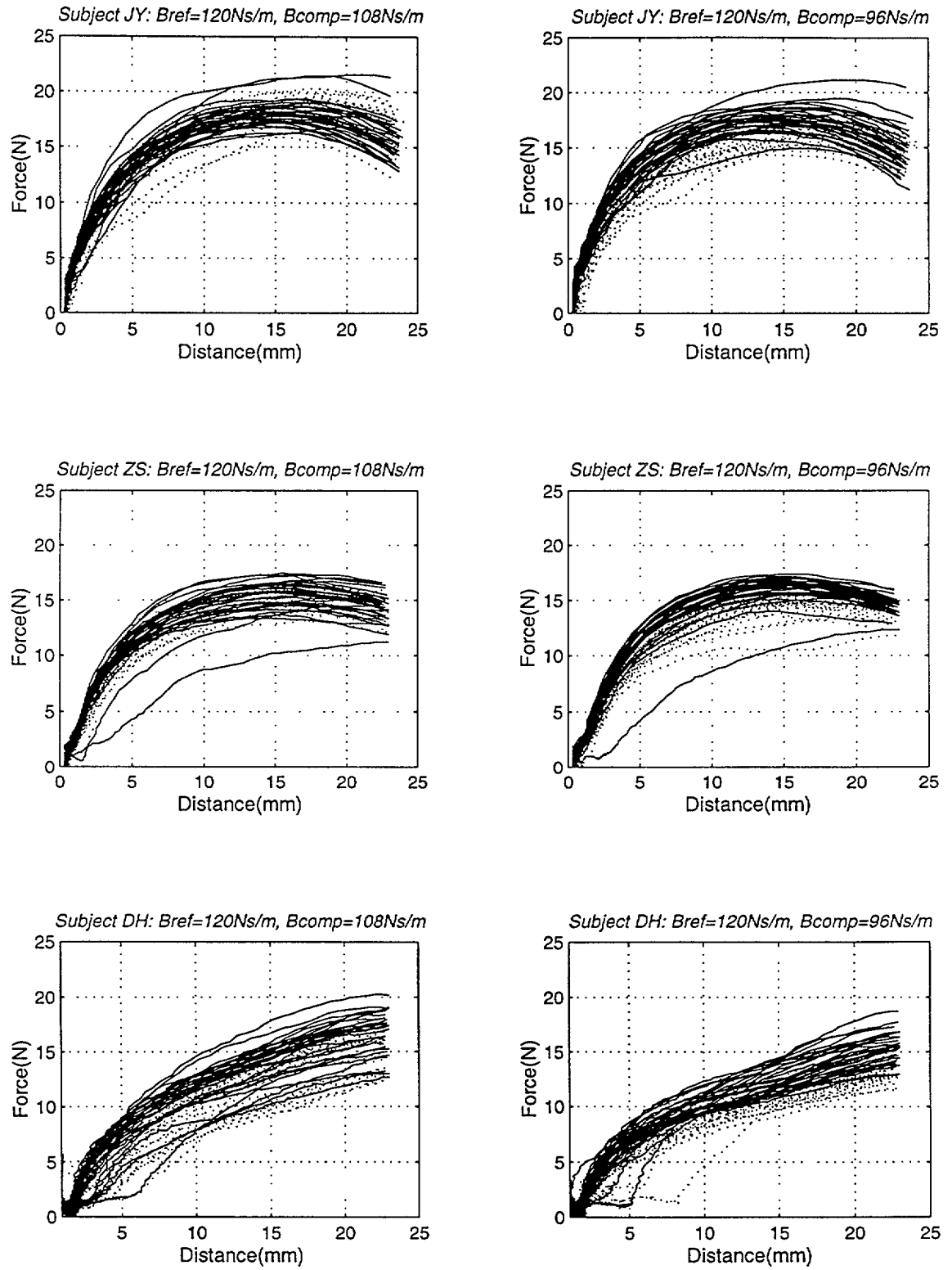

Figure 5.12: Applied Force versus Distance Plots for $\Delta B/B_o = 10\%$, $\Delta B/B_o = 20\%$

5.4, 5.6, and 5.8). In contrast, DH generally applied a ramping force over the entire squeezing distance, although some traces indicate leveling off in force around 20–25 mm.

Summaries of the overall force results for the three reference values of 60, 120 and 180Ns/m are presented in Tables 5.6 - 5.8. In each table, the data is organized by subject and stimulus pair. Results presented in each table include the average mean and peak applied force for each stimulus, the percent difference in average mean force for every stimulus pair and the average coefficient of variation in mean force for each stimulus over the course of an experimental run.

The average mean force was calculated for each stimulus by computing a mean force for each trial involving that stimulus and then computing an average over all such trials. To eliminate the effects of variable time delays on force averages, the mean force of every trial was determined by averaging over distance and not time. This was accomplished by dividing the total squeezing distance (a value of 25mm was used in all these experiments) into a series of equal 0.5 mm bins, determining an average force for each bin and then calculating the overall mean force for that trial by averaging over all bins. To provide some indication if approximately equal force profiles were applied with respect to distance for both stimuli, the percent difference in average mean force was also calculated.

Each peak force value presented in Tables 5.6 - 5.8 is an average of the maximum forces applied during each trial for that particular stimulus and is presented to provide information on the range of grasp forces used by the subjects in the experiments.

For every experimental run, the coefficient of variation in mean force data was calculated for both stimuli by dividing the standard deviation of the mean force by the average of the mean force. Each value for tables was then computed by averaging over all experimental runs involving that particular stimulus pair. These results are intended to provide a measure of the amount of variation in applied force that occurred during the course of an experimental run.

The data from the tables indicate that the average mean force for all subjects ranged from 5–7 Newtons when the reference viscosity was 60Ns/m. This is contrasted with the other two experiments where the average mean forces among subjects varied much more greatly: 9–16 Newtons for 120Ns/m and 5–17 Newtons for 180Ns/m. Average peak forces ranged from 6–9 Newtons for 60Ns/m to 13–22 Newtons for 120 and 180Ns/m, depending on subject and stimulus pair.

Even though the three subjects applied different average mean forces in the experiments, all subjects showed a systematic increase in the percent difference between the reference and comparison force values as the percent difference in stimulus pair also increased. This result seems to depend only on the percent difference in stimulus pairs. In other words, the percent difference in the average mean forces for a particular stimulus pair was generally independent of average mean force applied or the actual viscosities of the stimuli involved. When averaged over all experimental conditions and stimulus pairs, the percent difference between the average mean forces for the reference and comparison stimuli was approximately 10%. Thus, at least when averaged with respect to squeezing distance, the mean force applied for the reference is greater than the mean force for the comparison. A more thorough analysis of this result and its possible implications are presented in Chapter 8.

The average coefficient of variation in mean force over an experimental run was about 10% for the reference viscosities of 60 and 120Ns/m and about 15% for the reference viscosity of 180Ns/m. It is unclear why the coefficient of variation was greater at 180Ns/m. As opposed to the percent difference in average mean force data, the coefficient of variation data seems to be relatively independent of stimulus pair. It also appears to be independent of the average mean force, implying that when subjects apply greater forces, the variation in the average force value also increases, resulting in an approximately constant coefficient of variation.

Subject	$\Delta B/B_0$	Average Mean and (Peak) Reference Forces	Average Mean and (Peak) Comparison Forces	Percent Difference in Avg Mean Forces	Coeff. of Variation in Reference Force	Coeff. of Variation in Comp. Force
JY	25%	5.75N (6.93N)	4.85N (6.12N)	15.7%	8.7%	9.6%
	20%	5.63 (6.80)	5.03 (6.23)	10.7%	8.6%	8.9%
	15%	5.93 (7.17)	5.45 (6.66)	8.0%	8.2%	8.1%
	10%	5.88 (7.16)	5.68 (6.88)	3.4%	8.2%	8.7%
ZS	25%	7.03 (8.88)	5.95 (7.84)	15.3%	10.6%	10.4%
	20%	6.90 (8.60)	6.08 (7.77)	12.0%	9.1%	11.5%
	15%	6.98 (8.90)	6.25 (8.21)	10.4%	10.6%	12.2%
	10%	6.88 (8.78)	6.53 (8.46)	5.1%	10.4%	12.6%
DH	25%	5.84 (7.85)	5.00 (6.99)	14.4%	8.1%	10.6%
	20%	5.51 (7.69)	4.87 (6.69)	11.7%	10.6%	11.4%
	15%	6.49 (8.57)	5.94 (7.72)	8.4%	8.1%	10.8%
	10%	5.37 (7.76)	5.13 (7.44)	4.4%	20.3%	20.8%
Average		6.18N (7.92N)	5.56N (7.25N)	10.0%	10.1%	11.3%

Table 5.6: Summary Force Data for Reference Viscosity = 60 Ns/m

Subject	$\Delta B/B_0$	Average Mean and (Peak) Reference Forces	Average Mean and (Peak) Comparison Forces	Percent Difference in Avg Mean Forces	Coeff. of Variation in Reference Force	Coeff. of Variation in Comp. Force
JY	25%	15.83N (18.80N)	13.95N (17.25N)	11.9%	8.2%	11.2%
	20%	15.60 (18.54)	14.30 (17.32)	8.3%	8.7%	9.7%
	15%	15.58 (18.50)	14.78 (17.77)	5.1%	10.7%	10.2%
	10%	15.80 (18.75)	15.43 (18.50)	2.4%	8.8%	6.2%
ZS	25%	12.20 (14.48)	10.63 (13.23)	12.9%	10.1%	10.6%
	20%	13.15 (15.57)	11.80 (14.30)	10.3%	8.8%	7.1%
	15%	12.73 (14.96)	11.80 (14.12)	7.3%	6.5%	6.0%
	10%	12.85 (15.44)	12.15 (14.76)	5.5%	9.9%	9.1%
DH	25%	11.33 (16.68)	9.48 (13.92)	16.3%	9.7%	8.9%
	20%	11.32 (16.95)	9.71 (15.04)	14.3%	10.0%	15.9%
	15%	10.92 (16.29)	9.92 (14.89)	9.1%	10.5%	11.4%
	10%	11.54 (17.17)	10.49 (16.24)	9.1%	11.3%	16.5%
Average		13.24N (16.84N)	12.04N (15.61N)	9.4%	9.4%	10.2%

Table 5.7: Summary Force Data for Reference Viscosity = 120 Ns/m

Subject	$\Delta B/B_0$	Average Mean and (Peak) Reference Forces	Average Mean and (Peak) Comparison Forces	Percent Difference in Avg Mean Forces	Coeff. of Variation in Reference Force	Coeff. of Variation in Comp. Force
JY	25%	14.02N (20.91N)	13.73N (19.11N)	12.4%	18.4%	16.8%
	20%	15.40 (20.81)	14.93 (19.30)	10.9%	18.2%	17.4%
	15%	15.66 (21.03)	15.74 (20.06)	6.5%	13.52%	8.1%
	10%	17.08 (21.99)	16.08 (20.94)	5.7%	9.6%	18.8%
ZS	25%	8.60 (12.70)	7.06 (11.22)	18.0%	17.4%	20.6%
	20%	8.14 (12.19)	6.99 (10.90)	14.2%	16.5%	20.8%
	15%	8.48 (12.44)	8.02 (11.78)	5.4%	23.9%	19.9%
	10%	9.76 (14.44)	9.23 (13.93)	5.4%	16.5%	17.0%
DH	25%	11.32 (15.39)	10.01 (13.73)	11.6%	12.9%	8.3%
	20%	11.77 (15.89)	10.47 (14.24)	11.1%	9.8%	11.2%
	15%	10.53 (14.69)	9.55 (13.35)	9.3%	11.7%	11.6%
	10%	12.21 (16.28)	11.67 (15.50)	4.4%	15.2%	8.0%
Average		11.91N (16.56N)	11.12N (15.34N)	9.6%	15.3%	14.9%

Table 5.8: Summary Force Data for Reference Viscosity = 180 Ns/m

5.2.2.2 Velocity Data

Typical velocity data are plotted Figures 5.13 and 5.14. Each figure consists of six separate plots, two for each subject. Each plot consists of data from an entire experimental run. In Figure 5.13, velocity data are plotted versus time, while in Figure 5.14, the same velocity data are plotted versus squeezing distance. The reference viscosity is 120Ns/m for all plots. Similar to the force plots in Figure 5.11 and 5.12, graphs on the left side of each figure are from experiments when the difference between the reference and comparison stimuli was 10%, whereas graphs on the right are from experiments when the difference was 20%. For each graph, there are 64 force traces, one for each trial of an experimental run. Dotted line force traces indicate those trials when the reference viscosity was the stimulus while solid lines indicate trials when the comparison viscosity was the stimulus.

Because velocity is directly proportional to force in these experiments, the basic shape of the temporal and spatial velocity profiles are similar to the force traces shown in

the previous figures. Thus there is variation both in the magnitude of squeezing velocity and in the time delay before the plate begins to move. When velocity is plotted against distance in Figure 5.14, there is evidence of a difference in the velocity profiles for the reference and comparison stimuli. This difference can be seen as a separation in the groupings of the velocity profiles for the two stimuli, with the velocity profiles for the comparison stimulus generally greater than those for the reference stimulus. It can be observed most noticeably for JY and ZS in the plots on the right side of Figure 5.14, when the difference in the stimulus pair is 20%.

The overall velocity performance for the three subjects is presented in Tables 5.9 through 5.11 for the three reference viscosities. The data is organized by subject and stimulus pair. In each table, the average mean velocity for the reference and comparison stimuli are presented in the third and fourth columns. Similar to the mean force results, the mean velocities are also averaged over distance. The fourth and fifth columns contain data on the average peak velocities recorded during the experiments. The last column contains the percent difference between the two average mean velocities relative to the reference velocity.

Because velocity in these experiments was linearly proportional to force, the deviation in velocity as measured by the coefficient of variation would be essentially the same as force coefficient of variation data presented previously and therefore is not presented in these tables.

The data indicates that the average velocity over all subjects was around 100 to 110 mm/s for the reference viscosities of 60 and 120Ns/m, and approximately 70 mm/s for the reference viscosity of 180Ns/m. Average mean velocities for these experiments ranged from a minimum 50 mm/s to a maximum of 150 mm/s. Subject JY had the greatest overall average mean velocity of 114 mm/s, followed by ZS with an overall average mean velocity of 97 mm/s and DH with an overall average mean velocity of 67 mm/s. Average peak velocities ranged from 100–200 mm/s for reference viscosities of 60 and 120Ns/m and somewhat less than that for 180Ns/m, averaging over a range of 70–140 mm/s.

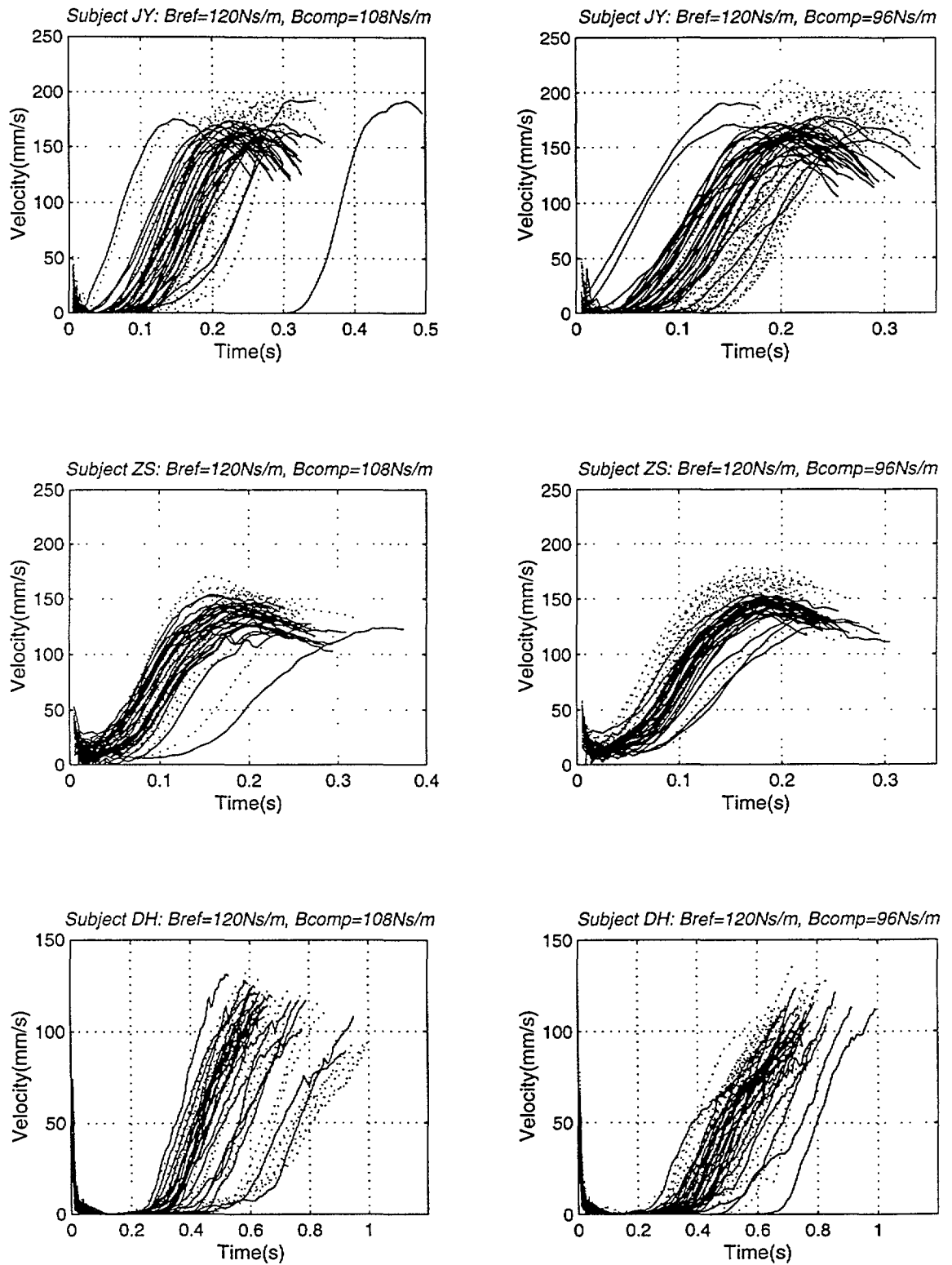

Figure 5.13: Velocity versus Time Plots for $\Delta B/B_o = 10\%$, $\Delta B/B_o = 20\%$

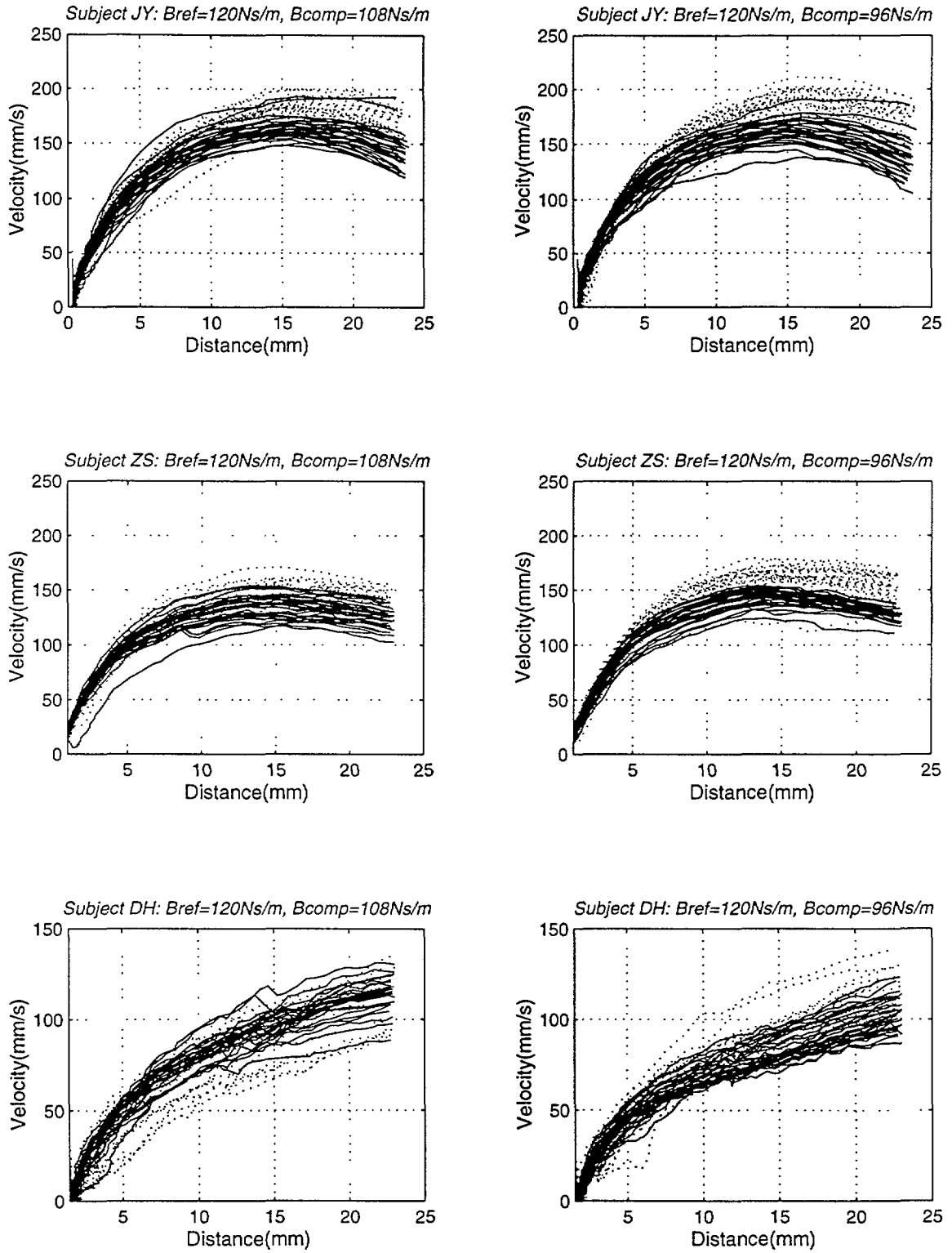

Figure 5.14: Velocity versus Squeezing Distance Plots for $\Delta B/B_0 = 10\%$, $\Delta B/B_0 = 20\%$

Subject	$\Delta B/B_0$	Average Mean Reference Velocity	Average Mean Comparison Velocity	Average Peak Reference Velocity	Average Peak Comparison Velocity	Percent Difference in Average Mean Velocities
JY	25%	96.3 mm/s	107.5 mm/s	119.5 mm/s	128.4 mm/s	-11.6%
	20%	91.9	100.8	121.3	132.4	-9.7%
	15%	96.0	103.3	115.3	130.9	-7.6%
	10%	94.3	100.7	121.3	142.8	-6.8%
ZS	25%	120.4	132.8	155.7	164.6	-10.3%
	20%	116.9	127.9	156.3	170.0	-9.4%
	15%	118.3	123.1	151.4	171.1	-4.1%
	10%	117.0	121.5	158.4	187.0	-3.9%
DH	25%	76.4	83.1	98.7	103.3	-8.8%
	20%	73.7	78.6	114.8	121.7	-6.6%
	15%	85.0	89.5	101.0	111.3	-5.3%
	10%	65.9	69.4	105.2	119.4	-5.3%
Average		96.0 mm/s	103.2 mm/s	126.6 mm/s	140.2 mm/s	-7.5%

Table 5.9: Summary Velocity Data for Reference Viscosity = 60 Ns/m

Subject	$\Delta B/B_0$	Average Mean Reference Velocity	Average Mean Comparison Velocity	Average Peak Reference Velocity	Average Peak Comparison Velocity	Percent Difference in Average Mean Velocities
JY	25%	134.6 mm/s	157.3 mm/s	161.3 mm/s	174.7 mm/s	-16.9%
	20%	132.8	151.4	160.1	181.1	-14.0%
	15%	132.4	147.5	159.8	187.1	-11.4%
	10%	133.5	145.2	162.6	198.5	-8.7%
ZS	25%	105.6	122.4	135.8	144.8	-15.9%
	20%	114.4	128.0	132.3	146.9	-11.9%
	15%	110.8	120.7	137.7	158.1	-8.9%
	10%	111.5	117.4	127.6	155.1	-5.2%
DH	25%	71.5	75.8	117.5	122.1	-8.7%
	20%	68.6	71.8	110.7	116.6	-5.2%
	15%	64.4	65.7	114.9	126.0	-5.9%
	10%	70.4	69.3	114.5	126.4	0.04%
Average		104.2 mm/s	114.4 mm/s	136.2 mm/s	153.1 mm/s	-9.4%

Table 5.10: Summary Velocity Data for Reference Viscosity = 120 Ns/m

Subject	$\Delta B/B_0$	Average Mean Reference Velocity	Average Mean Comparison Velocity	Average Peak Reference Velocity	Average Peak Comparison Velocity	Percent Difference in Average Mean Velocities
JY	25%	94.2 mm/s	109.2 mm/s	125.3 mm/s	132.0 mm/s	-15.9%
	20%	94.9	106.5	119.8	134.0	-12.3%
	15%	96.6	105.4	118.6	137.0	-9.1%
	10%	100.1	104.5	118.4	142.8	-4.5%
ZS	25%	48.8	53.3	81.7	87.9	-9.8%
	20%	46.1	49.7	71.5	79.8	-7.7%
	15%	49.0	53.2	69.9	78.1	-8.5%
	10%	55.3	57.9	73.3	84.3	-4.7%
DH	25%	64.3	72.6	92.4	97.4	-13.0%
	20%	65.8	72.3	84.0	89.7	-9.7%
	15%	58.6	62.2	90.1	100.6	-6.2%
	10%	68.3	71.9	88.1	104.0	-5.2%
Average		70.2 mm/s	76.6 mm/s	94.4 mm/s	105.6 mm/s	-8.9%

Table 5.11: Summary Velocity Data for Reference Viscosity = 180 Ns/m

The tables also indicate that the average mean velocity for the reference viscosity is almost always less than the corresponding average mean velocity for the comparison viscosity (the only exception was for subject DH when the reference viscosity was 120Ns/m and the difference and stimulus pairs was 10%). Similar to the force results, the percent difference in the reference and comparison velocities systematically increased as the difference in the stimulus pairs increased. This result occurred for all references and subjects. Overall the percent difference in the velocity for two stimuli was typically around 8.5%.

6

Mass Discrimination Results

6.1 Just Noticeable Difference

6.1.1 Fixed Displacement Results

The JND results for the fixed displacement mass discrimination experiments are plotted with respect to the various fixed squeezing distances in Figure 6.1. Subject JS completed a total of 4,032 trials, while subjects CK and JF both completed 4,480 trials. The average JND over the five fixed displacements of 15, 20, 25, 30, and 35 mm was 21.0%. This compares with average JND of 14.2% for fixed displacement viscosity discrimination experiments. The standard deviation was 1.6% indicating that the JNDs were relatively constant with respect to squeezing distance. JND data for the individual subjects are presented in Table 6.1. The standard deviation in the JND among the subjects was 2.6%. The β values presented in Table 6.2, are generally small for the experiments indicating that the subjects were unbiased in their responses.

Subject	15mm JND	20mm JND	25mm JND	30mm JND	35mm JND	Average JND
CK	23.0%	22.0%	28.3%	26.0%	23.2%	24.5%
JS	18.7%	24.0%	19.3%	21.0%	17.5%	20.1%
JF	18.9%	15.2%	20.7%	21.2%	15.5%	18.3%
Average	20.2%	20.4%	22.8%	22.7%	18.7%	21.0%

Table 6.1: JND Results for the Fixed Displacement Discrimination Experiments

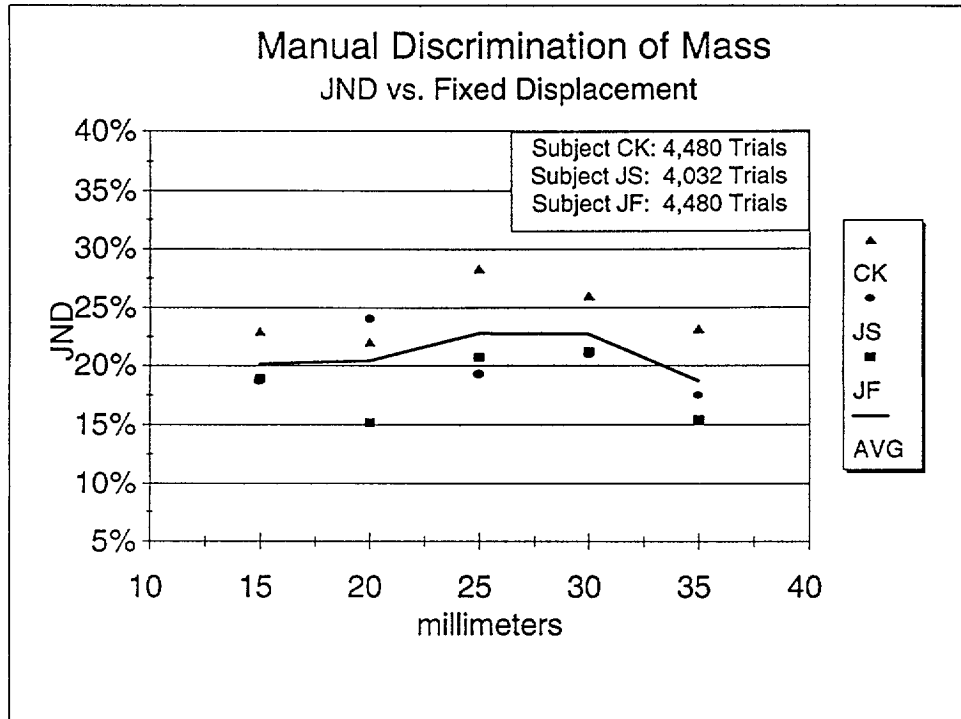

Figure 6.1: Mass JND versus Fixed Displacement

Subject	15mm β	20mm β	25mm β	30mm β	35mm β	Average β
CK	0.04	0.01	0.18	0.03	-0.01	0.05
JS	0.28	0.10	0.09	0.13	0.17	0.15
JF	0.20	0.07	0.06	0.13	0.20	0.13
Average	0.17	0.06	0.11	0.10	0.12	0.11

Table 6.2: Bias Results for the Fixed Displacement Discrimination Experiments

6.1.2 Different Reference Results

The JND results for different reference masses are presented in Figure 6.2. Subjects AM and JN completed a total of 3,072 trials, while subject BM completed a total of 2,944 trials. The average JND for all references was 19.0% with a standard deviation between references of 1.1%. Similar to the viscosity discrimination results, the JNDs are reasonably consistent with Weber's law. The average subject JNDs ranged from a low of 14.3% for subject AM to a high of 23.9% for subject DH. The standard deviation among

the subjects was 2.4%. The standard deviation for all experimental conditions was 2.9%. Individual subject results for JND and bias are presented in Tables 6.3 and 6.4, respectively. The bias results indicate that subjects did not appear to show a strong predilection towards selecting a particular response.

Subject	6 kg JND	9 kg JND	12 kg JND	Average JND
JN	19.9%	17.9%	21.4%	19.7%
AM	14.3%	17.0%	18.4%	15.9%
BM	22.2%	18.8%	23.9%	21.5%
Average	18.8%	17.8%	20.5%	19.0%

Table 6.3: JND Results for the Different Reference Masses

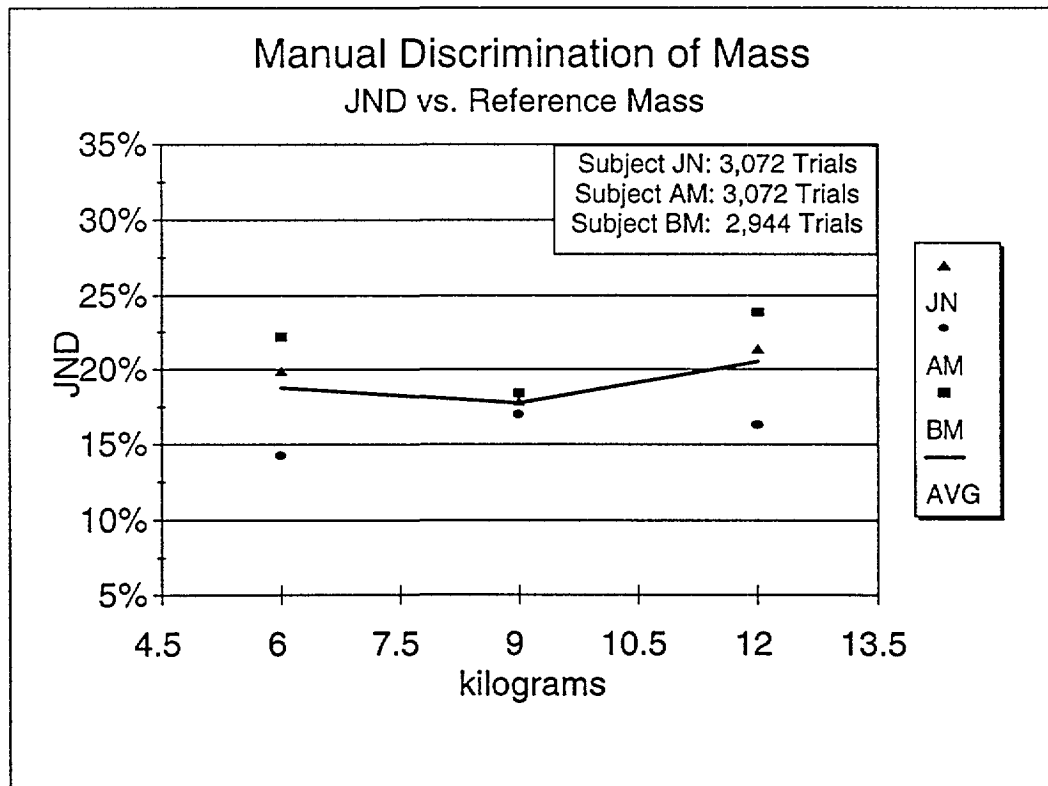

Figure 6.2: Mass JND versus Reference Mass

Subject	6 kg β	9 kg β	12 kg β	Average β
JN	0.11	0.16	0.13	0.13
AM	0.04	0.07	0.05	0.05
BM	-0.11	-0.06	0.05	-0.04
Average	0.01	0.06	0.08	0.05

Table 6.4: *Bias Results for the Different Reference Masses*

6.1.3 Overall Results

The average JND for subjects of both experiments was 20.0% with a standard deviation across subjects of 2.7%. The average JND for the subjects in the fixed displacement experiments was slightly higher than that for the subjects in the experiment involving different reference masses: 21.0% versus 19.0%. The mean JND values for the subjects ranged from a low of 14.3% for subject AM to a high of 28.3% for subject CK. The average over all experimental conditions was 20.3%, with a standard deviation of 3.4%.

6.1.4 Anecdotal Subject Observations

At the completion of the experiments, the subjects were asked to articulate what strategies or methods they utilized in the discrimination process. Some subjects stated that they discriminated on the basis of perceived differences in the “weight” or “heaviness” of the mass stimuli. Other subjects did not describe any particular strategy for discriminating the stimuli or simply felt that they discriminated on the basis of differences in “mass” or “inertia”. Consistent with the viscosity discrimination experiments, subjects, when their performance was optimal, felt that they could readily perceive differences in the stimuli during the initial grasping motion and did not require the full squeezing distance to make a decision. Subjects gave no description of the grasping or pinching action used in the experiments.

6.2 Motor Performance

Motor performance data were recorded during both sets of experiments. In the fixed displacement experiment, motor performance data were sampled every fourth trial over 9,024 trials for a total of 2,256 trials of data. In the discrimination experiment involving different reference masses, motor performance data were recorded for all 9,088 trials of the experiment.

6.2.1 Fixed Displacement Experiments

In the fixed displacement discrimination experiments, results for subjects CK, JS, and JF were from data sampled on every fourth trial over the course of 2,944, 2,944, and 3,136 trials respectively. Data sampling was carried out for all fixed displacements except 35mm. For every trial sampled, data acquisition was initiated once the moveable plate was at the designated start position. The motor performance results are divided into separate subsections for the force and acceleration data.

6.2.1.1 Force Data

Typical plots of the subjects' applied force versus time are shown Figure 6.3. In Figure 6.4, the same applied force data is plotted against squeezing distance. For all plots in Figures 6.3 and 6.4, the reference mass is 12kg and the fixed displacement is 25mm. Plots on the left side of each figure are from experiments when the difference between the reference and comparison stimuli was 10%, whereas graphs on the right are from experiments when the difference was 30%. Each trace on a plot represents data collected over a single trial during the experimental run. Because data was collected on every fourth trial there are sixteen traces for each plot. Dotted line force traces indicate those trials when the reference mass was the stimulus while solid lines indicate trials when the comparison mass was the stimulus.

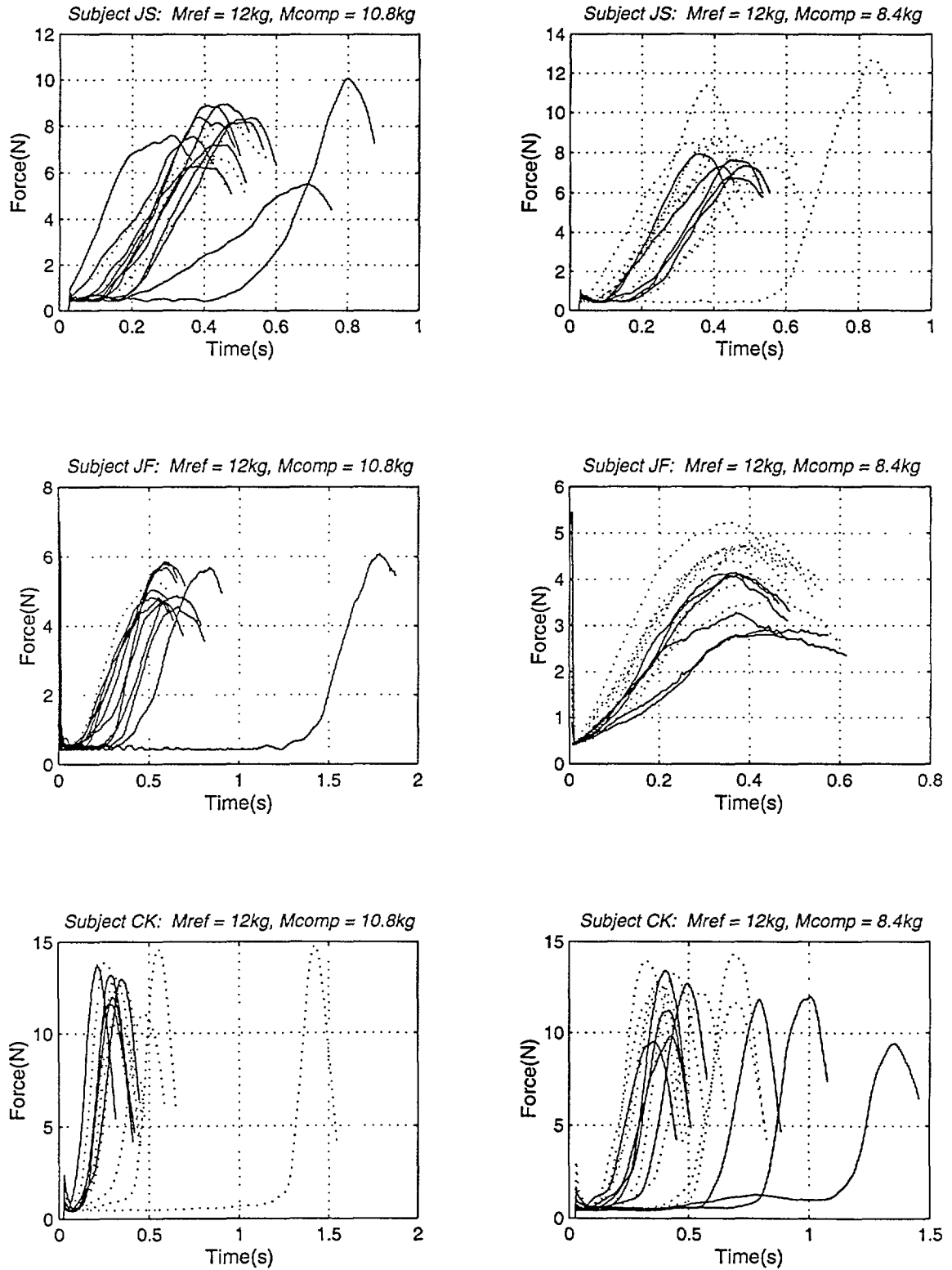

Figure 6.3: Applied Force versus Time for $\Delta M/M_o = 10\%$, 30%

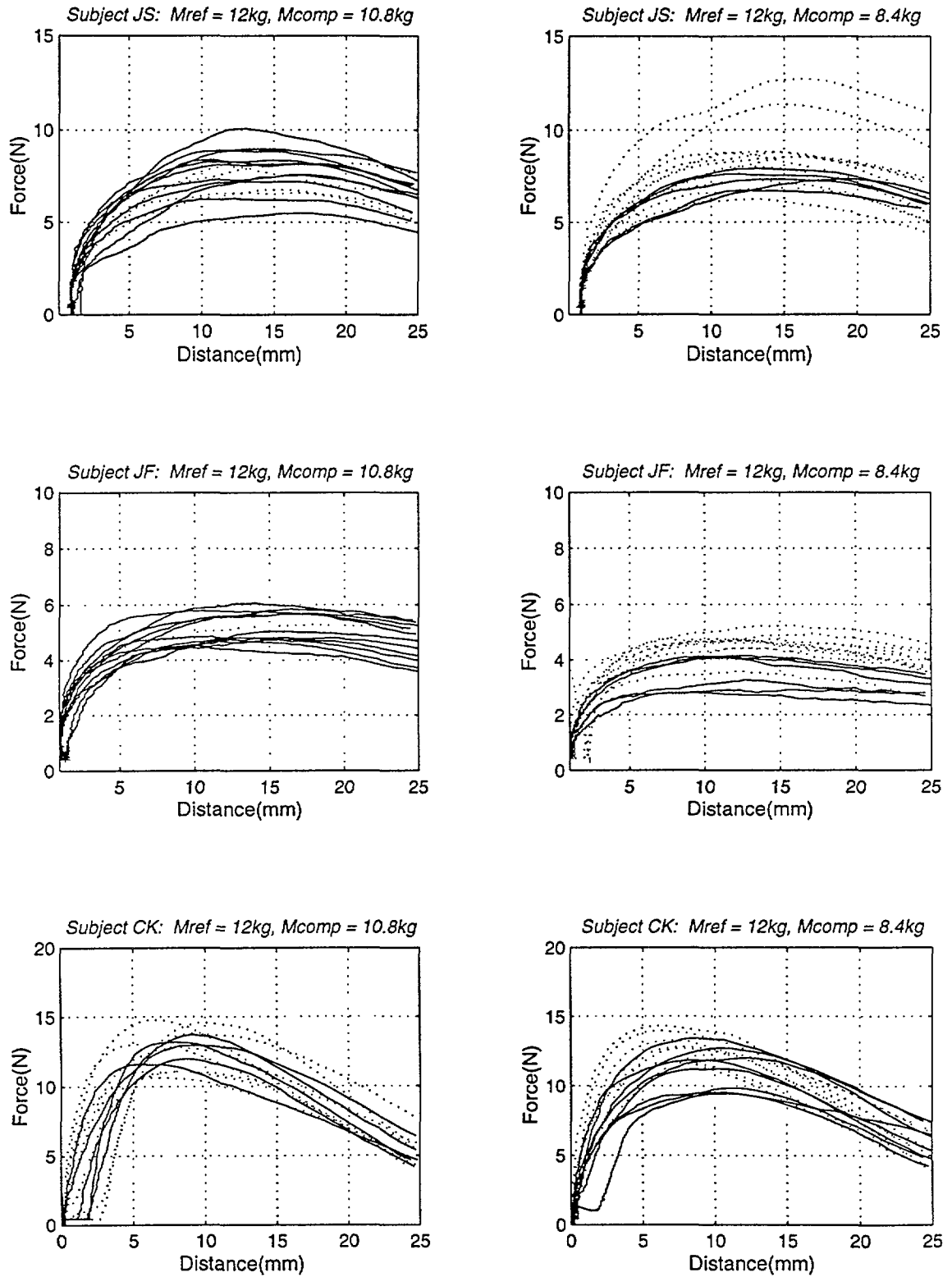

Figure 6.4: Applied Force versus Squeezing Distance for $\Delta M/M_o = 10\%$, 30%

The general shape of the temporal and spatial force profiles shows some similarities to the applied force plots shown in Chapter 5 for viscosity discrimination experiments. All plots show some time delay before force is applied to the plate, followed by force ramp up before a short duration peaking in applied force and finally a relaxation in the amount force applied as the plate approaches the mechanical stop.

Tabular results of the force data are presented in Tables 6.5 and 6.6. In Table 6.5 the force data is compiled by fixed displacement. Presented are the average mean and peak forces applied for the reference and comparison mass and the coefficient of variation results for both stimuli. The results have been averaged over all subjects and stimulus pairs.

The force data was calculated in the same fashion as in the viscosity discrimination experiments: The average mean force was calculated for each stimulus by computing a mean force for each trial involving that stimulus and then computing an average over all such trials. To eliminate the effect of variable time delays on force averages, the mean force of every trial was determined by averaging over distance and not time. This was accomplished by dividing each fixed displacement value for which data was recorded (15, 20, 25, and 30mm) into a series of equal 0.5 mm bins, determining an average force for each bin and then calculating the overall mean force for that trial by averaging over all bins. The peak force values presented in Tables 6.5 are averages of the maximum forces applied during each trial for the reference and comparison stimulus at each fixed displacement. It is presented to provide information on the range of grasp forces used by the subjects in the experiments.

For every experimental run, the coefficient of variation in mean force data was calculated for both stimuli by dividing the standard deviation of the mean force by the average of the mean force. Each value for tables was then computed by averaging over all experimental runs involving that particular stimulus. As with the viscosity discrimination experiments, these results are intended to provide a measure of the amount of variation in applied force that occurred during the course of an experimental run.

Fixed Displacement	Average Mean and (Peak) Reference Force	Average Mean and (Peak) Comparison Force	Coefficient of Variation in the Reference Force	Coefficient of Variation in the Comparison Force
15 mm	5.91N (8.40N)	5.48N (7.67N)	12.7%	14.1%
20 mm	5.30 (7.17)	4.81 (6.30)	16.0%	13.9%
25 mm	5.78 (9.56)	5.45 (8.96)	17.9%	17.4%
30 mm	5.55 (5.91)	5.09 (5.53)	15.8%	14.6%
Average	5.64N (7.76N)	5.21N (7.12N)	15.6%	15.0%

Table 6.5: Average Force Data During the Fixed Displacement Experiments

The data indicates that the average applied force for both reference and comparison stimuli did not vary greatly over variations in the fixed displacement. Over both stimuli, the mean force ranged from approximately 4.8 to 6.0 Newtons and the average peak forces ranged from 5.5 to 9.5 Newtons and did not appear to vary systematically with fixed displacement. For all fixed displacements, however, the mean and peak forces were always greater for the reference stimulus. Overall, the coefficient of variation results were typically around 15% for both the reference and comparison stimuli. The coefficient of variation in applied force also seemed to be independent of the value of the fixed displacement.

The force results are organized by subject and stimulus pair in Table 6.6. The force results in the table ranged from 3.7–6.7N depending on subject and stimulus pair. JF applied the lowest overall average mean force at 4.1N, and had an average coefficient of variation in applied force of 15.4%. CK had the highest overall average mean force at 6.3N, but exhibited the lowest average coefficient of variation in applied force at 14.1%. JS had an overall average mean force of 6.1N and the highest average coefficient of variation in applied force (17.0%).

Similar to viscosity discrimination experiments, all subjects exhibited a systematic increase in the difference between the average mean force (when calculated over squeezing distance) between the reference and comparison stimuli as the percent difference in stimulus pairs increased. Averaged over all subjects, the percent difference in average mean force was 0.0%, 4.0%, 11.6%, and 14.0% for $\Delta M/M_0 = 10\%$, 20%, 30% and 40%, respectively.

Subject	$\Delta M/M_0$	Average Mean Reference Force	Average Mean Comparison Force	Percent Difference in Average Mean Force	Coefficient of Variation for the Reference	Coefficient of Variation in the Comparison
JS	40%	6.29N	5.31N	15.6%	18.4%	17.7%
	30%	6.45N	5.76N	11.7%	17.7%	18.4%
	20%	6.57N	6.37N	4.2%	18.0%	12.8%
	10%	6.10N	6.19N	-2.5%	14.9%	17.7%
JF	40%	4.16N	3.67N	11.8%	17.6%	13.7%
	30%	4.26N	3.66N	14.0%	14.8%	13.3%
	20%	4.28N	4.08N	2.4%	15.9%	16.5%
	10%	4.21N	4.19N	0.0%	14.1%	14.9%
CK	40%	6.36N	5.57N	12.4%	12.4%	17.7%
	30%	6.42N	5.83N	9.3%	15.6%	12.3%
	20%	6.49N	6.17N	5.3%	12.9%	13.6%
	10%	6.68N	6.54N	2.4%	14.5%	17.0%
AVG		5.64N	5.21N	7.6%	15.6%	15.0%

Table 6.6: Force Results by Subject for the Fixed Displacement Experiments

There are some other similarities in the data: (1) The difference in the average mean force for the stimulus pair was always quite small (less than the force JND as measured by Pang et al 1991) when the percent difference in the mass stimuli was below or near JND and, and (2) The average mean force for the reference was approximately constant for all stimulus pairs.

6.2.1.2 Acceleration Data

Examples of typical acceleration data recorded during the experiments are plotted versus time and distance in Figures 6.5 and 6.6. The data is from the same trials plotted in

Figures 6.3 and 6.4 for the applied force data. The plots show peak accelerations ranging from 300 to 1200 mm/s^2 depending on subject and trial. Because force and acceleration are directly proportional in these experiments, the acceleration profiles have the same form as the force profiles. A summary of the average acceleration results for the different fixed displacements is given in Table 6.7. Acceleration results by subject and stimulus pair are presented in Table 6.8. Because force and acceleration data are proportional, coefficient of variation data for acceleration is not presented in either table.

The data in Table 6.7 indicates that the average mean acceleration for both stimuli was largely independent of fixed displacement, with the acceleration for the reference mass approximately 25% less than the comparison mass for all fixed displacements for which data was recorded. When averaged by fixed displacement, the mean acceleration values ranged from 440 to 620 mm/s^2 with overall mean acceleration for both stimuli of 530 mm/s^2 . The average peak acceleration values ranged from 500 to 900 mm/s^2 and like the mean acceleration values did not seem to vary systematically with fixed displacement.

Fixed Displacement	Average Mean and (Peak) Reference Acceleration	Average Mean and (Peak) Comparison Acceleration	Percent Difference in Average Mean Acceleration
15 mm	492 mm/s^2 (705 mm/s^2)	620 mm/s^2 (758 mm/s^2)	-25.6%
20 mm	442 (596)	540 (625)	-22.7%
25 mm	482 (790)	614 (881)	-27.4%
30 mm	462 (495)	576 (542)	-24.5%
<i>Average</i>	470 mm/s^2 (647 mm/s^2)	588 mm/s^2 (701 mm/s^2)	-25.1%

Table 6.7: Average Acceleration Data for the Fixed Displacement Experiments

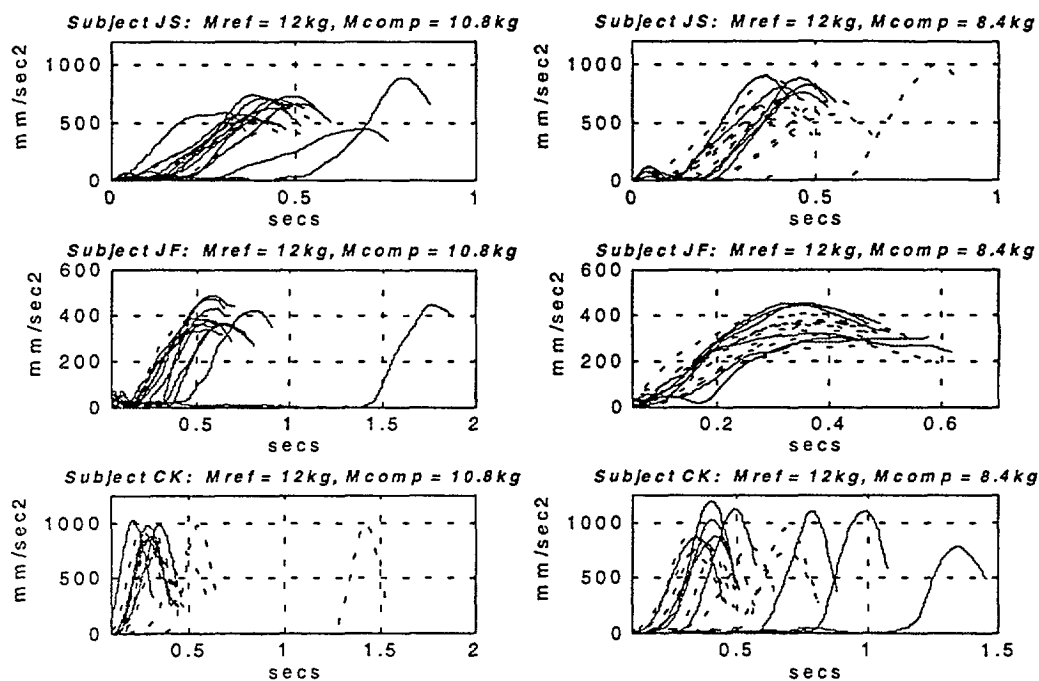

Figure 6.5: Acceleration versus time for $\Delta M/M_0 = 10\%, 30\%$

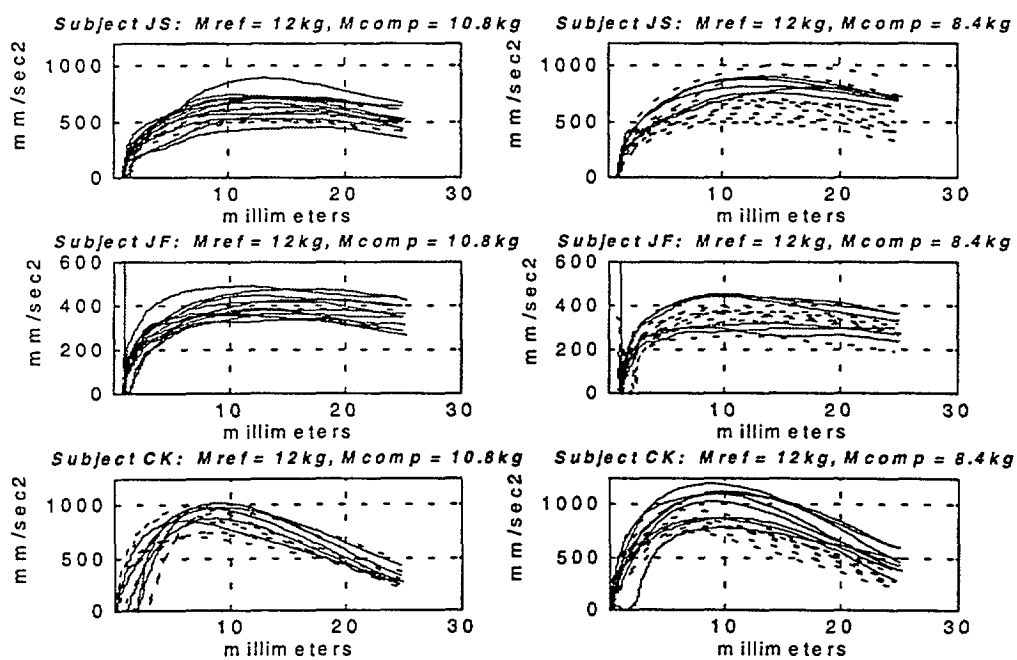

Figure 6.6: Acceleration versus squeezing distance for $\Delta M/M_0 = 10\%, 30\%$

Subject	$\Delta M/M_0$	Average Mean Reference Acceleration	Average Mean Comparison Acceleration	Percent Difference in Average Mean Acceleration
JS	40%	524 mm/s ²	738 mm/s ²	-40.7%
	30%	538	686	-27.6%
	20%	548	664	-21.1%
	10%	508	573	-12.8%
JF	40%	347 mm/s ²	509 mm/s ²	-46.9%
	30%	355	436	-22.9%
	20%	357	425	-19.3%
	10%	351	388	-10.4%
CK	40%	530 mm/s ²	773 mm/s ²	-45.8%
	30%	535	694	-29.8%
	20%	541	643	-18.8%
	10%	557	606	-8.9%
AVG		470	588	-25.1%

Table 6.8: Average Acceleration Data by Subject for the Fixed Displacement Experiments

The acceleration results in Table 6.8 ranged from 350–750 mm/s² depending on subject and stimulus pair. The overall average mean acceleration for subject JF was 396 mm/s² which was the lowest for the three subjects. Subjects CK and JS had comparable results with overall average mean accelerations of 610 and 597 mm/s², respectively. All subjects exhibited a systematic increase in the difference between the average mean acceleration for the reference and comparison stimuli as the difference in stimulus pairs increased. Averaged over all subjects, the percent difference in average mean acceleration was -10.7%, -19.7%, -26.8%, and -44.5% for $\Delta M/M_0 = 10\%$, 20%, 30% and 40%, respectively. Thus, the average mean acceleration for the reference mass was always less than the corresponding acceleration for the comparison mass and the percent difference in the two accelerations was roughly equivalent to the percent difference in the masses of the two stimuli.

6.2.2 Motor Performance for Different Reference Masses

In the mass discrimination experiments with different references, motor performance data was recorded for all trials. Thus data was recorded during 3,072 trials for subjects AM and JN and during 2,944 trials for subject BM. Data sampling was initiated once the moveable plate was at the designated start position. The motor performance results are divided into separate subsections for the force and acceleration data. Additional plots of data from these experiments can be found in Appendix C.

6.2.2.1 Force Data

Typical plots of the subjects' applied force versus time are shown Figure 6.8. In Figure 6.9, the same applied force data is plotted against squeezing distance. For all plots in Figures 6.8 and 6.9, the reference mass is 9kg and the fixed displacement is 25mm. Plots on the left side of each figure are from experiments when the difference between the reference and comparison stimuli was 10%, whereas graphs on the right are from experiments when the difference was 30%. Each trace on a plot represents data collected over a single trial during the experimental run. Because data was collected on every trial there are sixty four traces for each plot. Dotted line force traces indicate those trials when the reference mass was the stimulus while solid lines indicate trials when the comparison mass was the stimulus.

The basic shape of the temporal and spatial force profiles are generally consistent with the force profiles shown in Chapter 5 for the viscosity discrimination experiments and in the previous section for the other mass discrimination experiments. The temporal force profiles in Figure 6.8 show variation in both the time delay before force is applied to the moveable plate and in the amount of force that is applied. However almost all force traces consistently show a relatively long duration ramping up of applied force, followed by a shorter duration peaking and decrease in applied force. Although the duration of the force ramp seems to make up a considerable amount of the temporal force profile, it occurs over a relatively short squeezing distance, as seen in Figure 6.9. In these plots, subjects

typically reached peak applied force within 5 to 10 mm of travel, followed by flat or decreasing force profiles over the remaining distance.

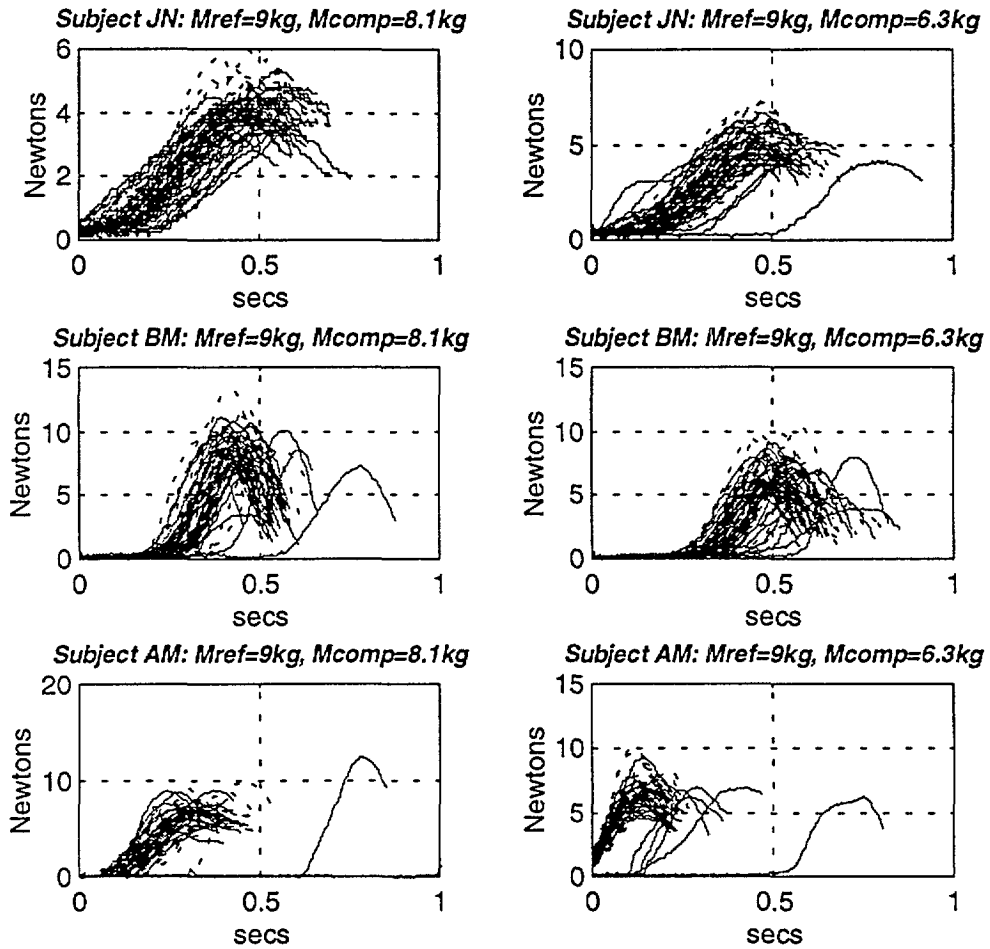

Figure 6.7: Applied Force versus Time for $\Delta M/M_0 = 10\%$, 30%

The overall force data results are presented in Tables 6.9 - 6.11. In Table 6.9, data is shown for the 6kg reference and in Tables 6.10 and 6.11, the results are given for 9kg and 12kg, respectively. Similar to the force data presented in the fixed discrimination experiments, the average mean and peak force for both the reference and comparison stimuli, the percent difference in the average mean forces and the coefficient of variation in mean force are presented. The data is organized by subject and stimulus pair.

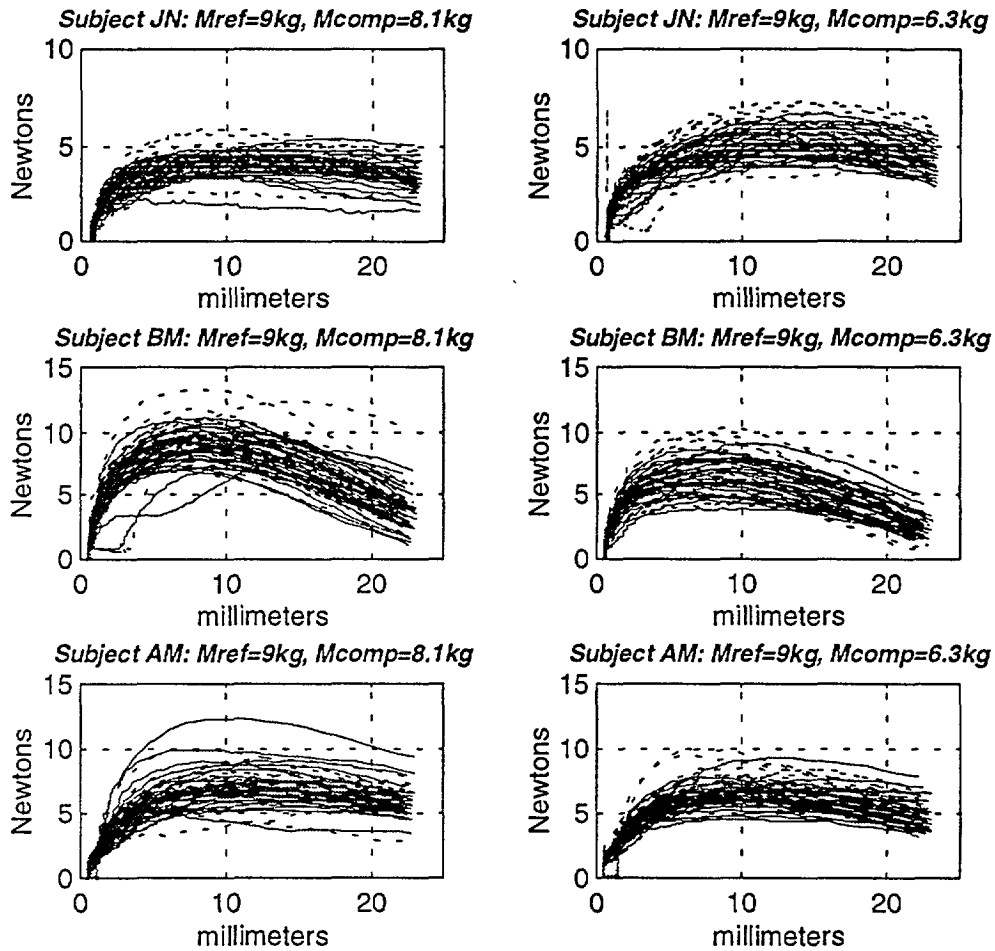

Figure 6.8: Applied Force versus Squeezing Distance for $\Delta M/M_o = 10\%$, 30%

The results indicate that the average mean force over all references was 5.9N for the reference stimulus and 5.5N over all comparison stimuli. The average mean forces ranged from 2.5–9.5N and the average peak forces ranged from 4.5–12N, depending on subject and experimental condition. Whereas, the average mean force applied increased with reference mass, the average percent difference in mean force for the reference and comparison was relatively invariant ($7.8\% \pm 0.7\%$) with reference mass. Both the overall average mean force and the percent difference are approximately equal to the results in the fixed displacement mass discrimination experiments (Refer to Table 6.7).

The percent difference in average mean force shows the same trend observed in the fixed displacement mass discrimination experiments and the viscosity discrimination experiments. When averaged over displacement, the percent difference in force increases with stimulus pair difference. This is observed at each reference mass for all subjects. Averaged over all subjects, the percent difference in average mean force was 1.9%, 5.8%, 8.8%, and 14.5% for $\Delta M/M_0 = 10\%$, 20%, 30% and 40%, respectively. Thus, the average mean force for the reference mass was always greater than the corresponding force for the comparison mass. The overall percent difference between the two average mean forces was 7.2%, 7.2%, 8.9% for subjects AM, BM, and JN respectively.

The overall coefficient of variation in applied force was approximately 17% for both stimuli; it was greater than 20% when the reference mass was 12kg and was 14–16% for the other two references. As seen with previous coefficient of variation data, the results are generally independent of stimuli for the same reference.

Subject	$\Delta M/M_0$	Average Mean and (Peak) Reference Force	Average Mean and (Peak) Comparison Force	Percent Difference in Avg Mean Force	Coefficient of Variation in the Reference Force	Coefficient of Variation in the Comparison Force
AM	40%	6.90N (8.28N)	6.05N (7.18N)	12.6%	12.3%	10.5%
	30%	6.66 (7.86)	6.09 (7.12)	8.6%	10.4%	9.1%
	20%	6.79 (8.13)	6.42 (7.56)	5.4%	11.2%	8.4%
	10%	6.81 (8.08)	6.82 (8.13)	-0.3%	10.9%	10.8%
BM	40%	4.06 (5.59)	3.65 (4.85)	10.0%	16.1%	13.6%
	30%	4.18 (5.64)	3.90 (5.14)	6.7%	14.2%	14.0%
	20%	4.05 (5.56)	3.91 (5.31)	3.3%	15.1%	15.2%
	10%	4.80 (6.41)	4.65 (6.25)	3.2%	15.8%	17.8%
JN	40%	3.30 (4.31)	2.63 (3.62)	20.2%	13.9%	20.0%
	30%	2.92 (4.07)	2.61 (3.57)	10.6%	23.7%	19.6%
	20%	3.21 (4.31)	3.01 (3.99)	6.2%	14.8%	13.7%
	10%	2.97 (4.08)	2.92 (3.92)	1.6%	29.2%	18.4%
AVG		4.72N (6.03N)	4.39N (5.55N)	7.8%	15.6%	14.3%

Table 6.9: Force Results by Subject and Stimulus Pair for 6kg

Subject	$\Delta M/M_0$	Average Mean and (Peak) Reference Force	Average Mean and (Peak) Comparison Force	Percent Difference in Avg Mean Force	Coefficient of Variation in the Reference Force	Coefficient of Variation in the Comparison Force
AM	40%	6.20N (7.57N)	5.38N (6.57N)	13.2%	12.5%	17.7%
	30%	6.37 (7.91)	5.82 (7.30)	8.7%	17.4%	21.4%
	20%	5.77 (7.27)	5.41 (6.89)	6.2%	16.4%	17.9%
	10%	5.88 (7.46)	5.86 (7.32)	0.3%	21.8%	20.4%
BM	40%	7.88 (9.32)	6.60 (7.69)	16.3%	12.4%	12.1%
	30%	7.05 (8.60)	6.40 (7.57)	9.1%	15.2%	16.4%
	20%	8.53 (10.3)	7.90 (9.39)	7.4%	11.8%	11.6%
	10%	7.50 (9.08)	7.29 (8.82)	2.7%	14.6%	15.4%
JN	40%	4.23 (5.06)	3.55 (4.67)	16.2%	21.4%	13.5%
	30%	4.70 (5.80)	4.19 (4.87)	10.8%	22.2%	14.1%
	20%	4.74 (5.83)	4.40 (5.36)	7.3%	18.3%	13.5%
	10%	4.18 (5.18)	4.02 (4.67)	3.8%	16.1%	13.0%
AVG		6.08N (7.44N)	5.59N (6.19N)	8.5%	16.6%	15.6%

Table 6.10: Force Results by Subject and Stimulus Pair for 9kg

Subject	$\Delta M/M_0$	Average Mean and (Peak) Reference Force	Average Mean and (Peak) Comparison Force	Percent Difference in Avg Mean Force	Coefficient of Variation in the Reference Force	Coefficient of Variation in the Comparison Force
AM	40%	9.49N (12.0N)	8.32N (10.3N)	12.3%	15.5%	11.0%
	30%	8.27 (10.5N)	7.54 (9.55)	8.8%	17.4%	18.1%
	20%	8.85 (11.2N)	8.21 (10.4)	7.2%	13.7%	18.5%
	10%	8.93 (11.1N)	8.66 (10.8)	3.0%	15.0%	16.7%
BM	40%	6.51 (9.20)	5.54 (7.76)	14.9%	18.3%	23.7%
	30%	6.39 (8.92)	5.96 (7.95)	6.7%	16.8%	18.3%
	20%	6.26 (8.96)	6.06 (8.62)	3.1%	17.8%	29.8%
	10%	6.43 (9.32)	6.20 (8.84)	3.5%	22.5%	20.7%
JN	40%	5.45 (7.53)	4.63 (6.16)	15.0%	22.6%	22.1%
	30%	5.97 (9.01)	5.43 (8.13)	8.9%	27.4%	28.5%
	20%	5.56 (9.19)	5.22 (8.38)	6.1%	27.1%	28.3%
	10%	6.05 (9.06)	6.07 (8.87)	-0.4%	25.8%	19.8%
AVG		7.01N (9.67N)	6.49N (8.81N)	7.4%	20.0%	21.3%

Table 6.11: Force Results by Subject and Stimulus Pair for 12kg

6.2.2.2 Acceleration Data

Examples of acceleration data typically recorded during the discrimination experiments are presented in Figures 6.9 and 6.10. In Figure 6.9, the data is plotted versus time and in Figure 6.10 the same acceleration data is plotted versus displacement. The graphs show data from all three subjects and are organized in the same format as

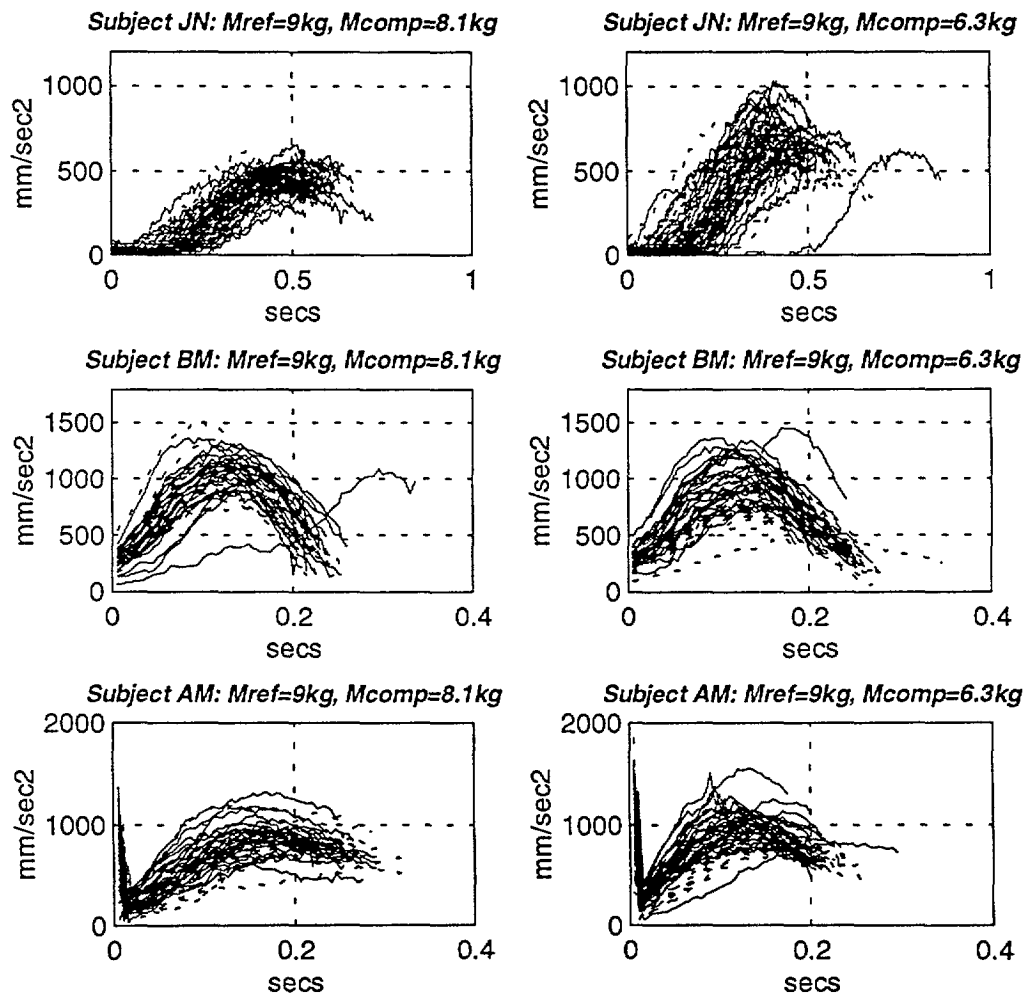

Figure 6.9: Acceleration versus Time for $\Delta M/M_0 = 10\%$, 30%

utilized in Figures 6.7 and 6.8. The dotted lines represent data from trials where the reference mass was the stimulus and solid lines represent acceleration data from the trials where comparison mass was the stimulus.

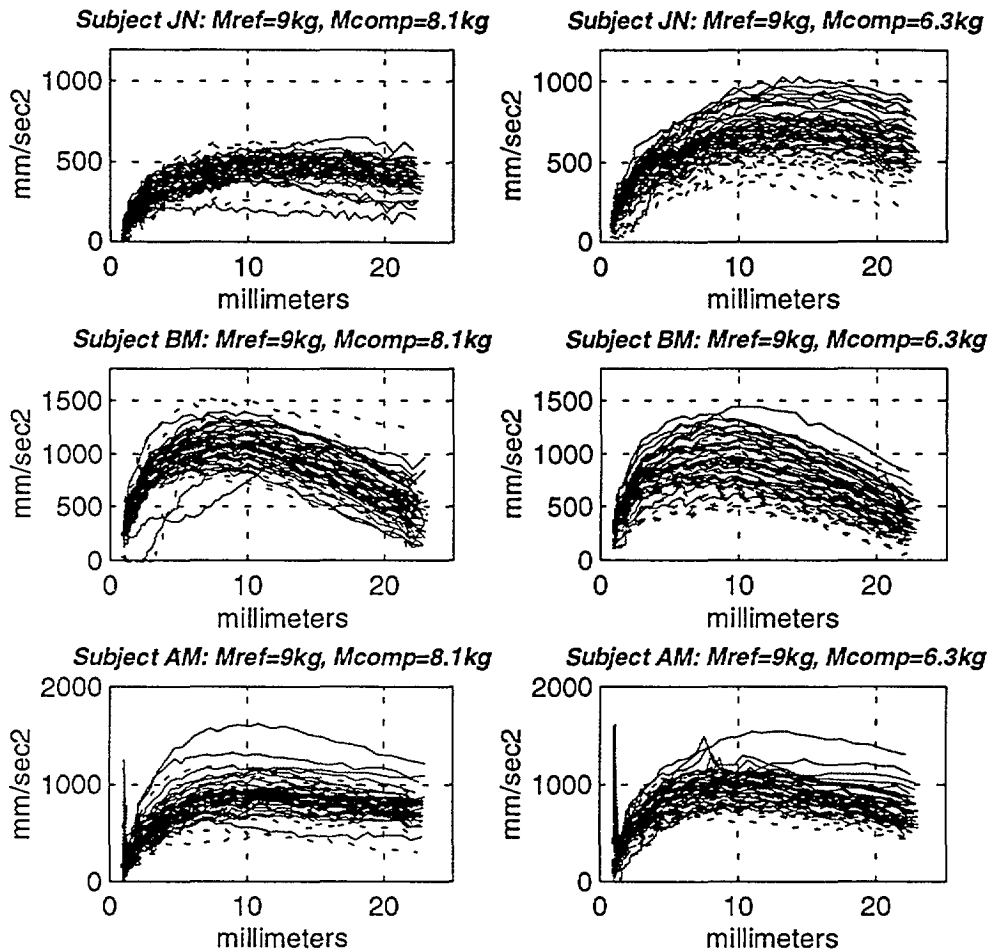

Figure 6.10: Acceleration versus Squeezing Distance for $\Delta M/M_o = 10\%$, 30%

The plots of acceleration show peak accelerations ranging from 300 - 1500mm/s² depending on subject and trial. The acceleration spikes in the beginning of some of the acceleration traces for subject AM are artifacts caused by contact between the moveable plate and the mechanical stop of the Linear Grasper, immediately before the trial started.

A summary of the acceleration data by the three reference masses of 6, 9, and 12kg is presented in Table 6.12. The data in table indicates that while the average mean acceleration for both stimuli decreased as reference mass increased, the percent difference in average mean acceleration for the reference and comparison mass remained approximately constant ($23\% \pm 2\%$). When averaged over all masses, the mean

acceleration values ranged from 570 to 940 mm/s^2 with overall mean acceleration for both stimuli of 688 mm/s^2 . Average peak acceleration values ranged from 928 to 1326 mm/s^2 .

Reference Mass	Average Mean and (Peak) Reference Acceleration	Average Mean and (Peak) Comparison Acceleration	Percent Difference in Average Mean Acceleration
6 kg	757 mm/s^2 (1177 mm/s^2)	939 mm/s^2 (1326 mm/s^2)	-23.9%
9 kg	666 (928)	812 (1072)	-21.6%
12 kg	568 (1110)	704 (1190)	-23.8%
Average	664 (1078)	818 (1196)	-23.1%

Table 6.12: Average Acceleration Data by Reference Mass

Subject	$\Delta M/M_0$	Average Mean Reference Acceleration	Average Mean Comparison Acceleration	Percent Difference in Average Mean Acceleration
AM	40%	856 mm/s^2	1,216 mm/s^2	-42.2%
	30%	822	1,052	-28.2%
	20%	816	952	-16.5%
	10%	832	910	-9.3%
BM	40%	692 mm/s^2	972 mm/s^2	-40.8%
	30%	658	858	-30.5%
	20%	707	831	-18.2%
	10%	714	766	-7.2%
JN	40%	462 mm/s^2	616 mm/s^2	-33.6%
	30%	471	592	-25.8%
	20%	480	555	-15.7%
	10%	457	499	-9.1%
AVG		664	818	-23.1%

Table 6.13: Average Acceleration Data by Subject

The mean acceleration results in Table 6.13 ranged from 450-1,200 mm/s^2 depending on subject and stimulus pair. The overall average mean acceleration for subject

JN was 517 mm/s^2 which was the lowest for the three subjects. Subjects BM and AM had greater overall average mean accelerations of 775 and 932 mm/s^2 , respectively. All subjects exhibited a systematic increase in the difference between the average mean acceleration for the reference and comparison stimuli as the difference in stimulus pairs increased. Averaged over all subjects, the percent difference in average mean acceleration was -8.5% , -16.8% , -28.2% , and -38.9% for $\Delta M/M_0 = 10\%$, 20% , 30% and 40% , respectively. Thus as was the case with the fixed displacement discrimination experiments, the average mean acceleration for the reference mass was always less than the corresponding acceleration for the comparison mass and the percent difference in the two accelerations was roughly equivalent to the percent difference in the masses of the two stimuli.

7

Velocity and Acceleration Discrimination Results

7.1 Velocity JND Results

The JND results for the velocity discrimination experiments are plotted with respect to the various reference velocities in Figure 7.1. The subjects for the velocity discrimination experiments are the same group of subjects that took part in the viscosity discrimination experiments involving the different reference viscosities. In these experiments, subject DH completed a total of 2,000 trials, while subjects JY and DH both completed 2,400 trials. The average JND over the four reference velocities of 60, 80, 100, and 120 mm/sec was 10.9%. The standard deviation between the JNDs for the individual reference velocities was 1.0% indicating that the JNDs were relatively constant with respect to reference velocity. However, as seen in Figure 7.1, there is a slight decrease in the velocity JND as the reference velocity increases.

The JND data for the individual subjects and various reference velocities are presented in Table 7.1. The standard deviation in the JND among the subjects was 0.9%. The standard deviation over all experimental conditions was 1.7%. Subject DH had the lowest average velocity JND of 9.7%, followed by ZS with an average JND of 11.1% and JY with an average JND of 11.9%. The bias results are presented in Table 7.2. The β values are generally small and negative for the experiments indicating that the subjects had a slight preference for selecting the lesser velocity stimulus in their responses.

Subject	60 mm/sec JND	80 mm/sec JND	100 mm/sec JND	120 mm/sec JND	Average Subject JND
JY	13.4%	12.3%	13.0%	8.7%	11.9%
ZS	11.0%	12.3%	9.9%	11.3%	11.1%
DH	11.9%	10.2%	8.0%	8.8%	9.7%
Average	12.1%	11.6%	10.3%	9.6%	10.9%

Table 7.1: JND Results for the Velocity Discrimination Experiments

Subject	60 mm/sec β	80 mm/sec β	100 mm/sec β	120 mm/sec β	Average Subject β
JY	-0.18	-0.20	-0.05	-0.18	-0.15
ZS	-0.26	-0.21	-0.11	-0.11	-0.17
DH	-0.11	0.04	-0.02	0.02	-0.02
Average	-0.18	-0.12	-0.06	-0.09	-0.11

Table 7.2: Bias Results for the Velocity Discrimination Experiments

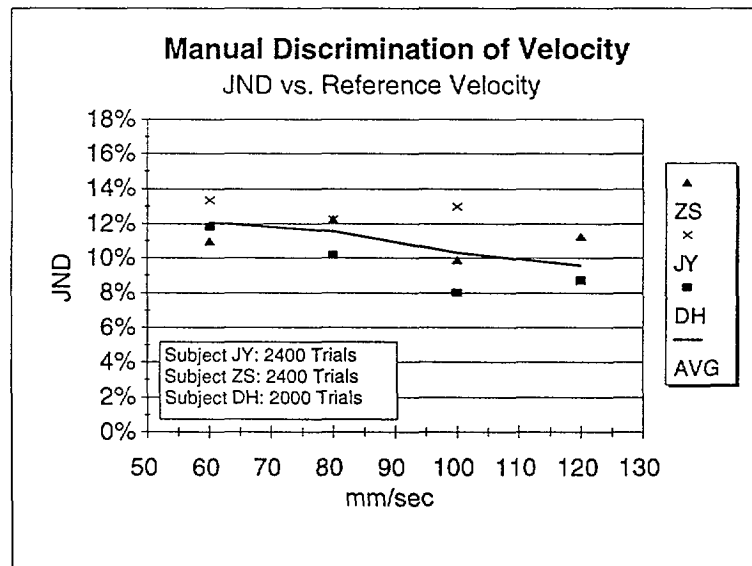

Figure 7.1: JND Results for the Velocity Discrimination Experiments

7.2 Acceleration JND Results

The JND results for the acceleration discrimination experiments are presented in Figure 7.2. The subjects for the acceleration discrimination experiments are the same group of subjects that took part in the mass discrimination experiments involving the different reference masses. Subject JN completed a total of 2,400 trials, while subject BM completed a total of 1,400 trials and subject AM completed a total of 1,836 trials. Subject AM and JN completed the discrimination experiments for the four reference accelerations of 400, 800, 1200, and 1600 mm/sec², and BM completed the experiments for all reference accelerations except 400 mm/sec². The average JND for all references was 16.9% with a standard deviation between the individual reference accelerations of 3.0%. The JND results plotted in Figure 7.2, indicate a large decrease in JND as the reference acceleration increases from 400 and 800 mm/sec² and then an increasing JND as the references increase to 1200 and 1600 mm/sec².

The average subject JNDs ranged from a low of 14.1% for subject AM to a high of 19.8% for subject JN. The standard deviation among the subjects was 2.3%. The standard deviation for all experimental conditions was 4.2%. JND and bias results for the subjects and references are presented in Tables 7.3 and 7.4, respectively. Overall the bias results indicate that subjects did not appear to show a strong predilection towards selecting a particular response, with the exception of BM when the reference acceleration was 1200 mm/sec². For that particular experiment, BM shows a reasonably strong bias towards selecting the lesser acceleration stimulus as the response.

Subject	400 mm/sec ² JND	800 mm/sec ² JND	1200 mm/sec ² JND	1600 mm/sec ² JND	Average Subject JND
JN	21.8%	15.7%	19.8%	22.0%	19.8%
AM	20.5%	11.5%	11.6%	12.9%	14.1%
BM	N/A	11.3%	18.9%	19.7%	16.6%
Average	21.2%	12.8%	16.8%	18.2%	16.9%

Table 7.3: JND Results for the for the Acceleration Discrimination Experiments

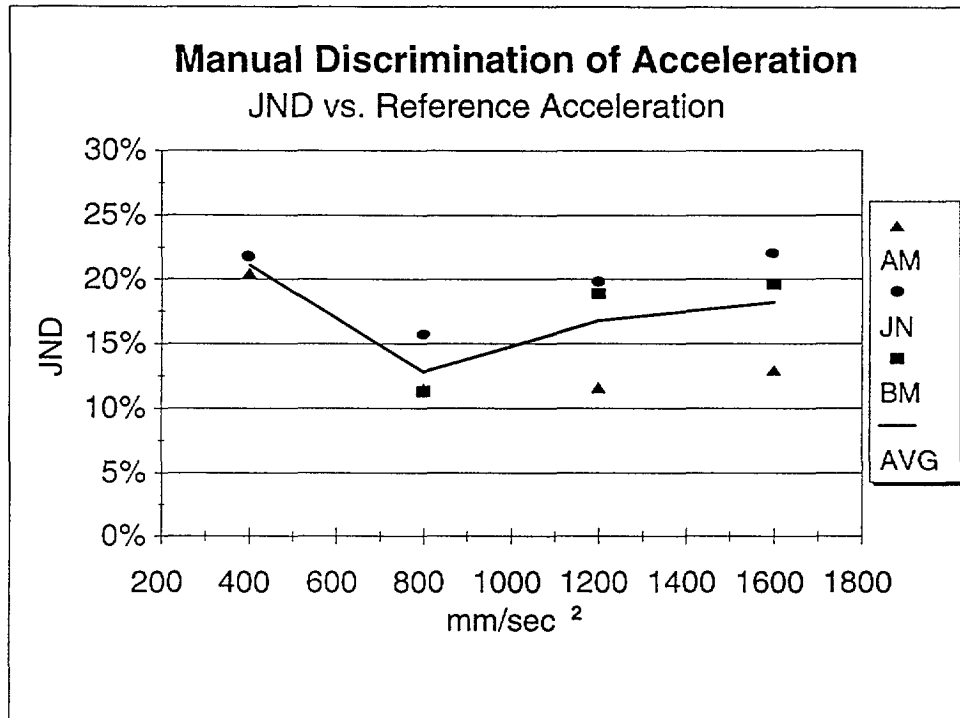

Figure 7.2: JND Results for the Acceleration Discrimination Experiments

Subject	400 mm/sec ² β	800 mm/sec ² β	1200 mm/sec ² β	1600 mm/sec ² β	Average β
JN	-0.02	-0.24	0.02	0.13	-0.03
AM	-0.03	-0.15	0.20	0.06	0.02
BM	N/A	0.00	-0.62	0.02	-0.20
Average	-0.03	-0.13	-0.13	0.07	-0.07

Table 7.4: Bias Results for the Acceleration Discrimination Experiments

8

Analysis of Sensorimotor Interactions

8.1 Introduction

During the viscosity and mass discrimination experiments, haptic motor performance data were recorded for 20,960 trials. From a human factors perspective, this information can be used to provide meaningful quantitative data about the range of forces, velocities and accelerations used during grasp discrimination tasks. More importantly, from the standpoint of understanding haptic perceptual processes, this data arises from controlled motor actions undertaken by subjects during specific manual discrimination tasks. In essence, subjects have chosen these particular motor actions for the discrimination tasks they have been asked to do. Unlike experiments with a linear compliance where force value is determined by the distance squeezed, in the case of viscosity and mass, the force values are governed by velocity and acceleration profiles, both of which are arbitrarily chosen by the subjects. As a result, it is not unreasonable to expect that the motor data should help in characterizing the grasping strategies used by the subjects. Furthermore, an analysis of the motor actions, in concert with the JND results from chapters 5 through 7, should provide insight into how the motor performance strategy affected the discrimination performance of the subjects.

Specifically, we would like to be able to answer certain questions about subjects' performance, such as: Is there an underlying discrimination strategy that is utilized by all

subjects in both the viscosity discrimination and mass discrimination tasks? Or conversely, can we use the motor performance data from the subjects to argue against certain discrimination strategies? More generally, can we learn anything from the analysis of motor performance and JND results that could allow us to predict discrimination performance for more complicated object properties.

8.2 Analysis of Motor Performance Data

8.2.1 Average Temporal Force Ramps are the Same for Both Stimuli

It is unclear at which point during the grasping action that a subject makes a decision about the nature of the stimulus. For stimulus pairs near or below JND, it is quite possible that subjects must use the entire squeezing distance. But, when the difference in the reference and comparison is larger than JND, it is also possible that a subject could make a decision earlier during the grasping action and not require the entire squeezing distance. In this case, the usefulness of motor data recorded after a subject has made a decision is unclear. However, since the subjects do not know which stimulus will be presented on a given trial, any consistency in the motor data should at least be evident during some initial grasping action.

Plots of applied force versus time are shown in Figures 5.11, 6.13, and in Appendices B and C for subjects from both the viscosity and mass discrimination experiments. These figures show, regardless of stimuli, when subjects initially grasp the plates they tend to apply an increasing force ramp with respect to time. To determine whether the initial force ramps of the reference and comparison stimulus were different, average force ramp functions were determined. These functions were calculated by averaging over a fixed time interval the force data for all the trials of that stimulus that were greater than a certain threshold force. The threshold force was utilized to eliminate the variability in time delay that was present among trials before the initial force ramp began. The value of the threshold was visually predetermined for every

experimental run and was typically between 0.5 - 1.5 Newtons. The fixed time interval was determined by calculating the average time required for the subjects' applied force ramp to reach 90% of its peak value.

Typical ramp functions are plotted in Figure 8.1 - 8.4. The force plots in Figures 8.1 and 8.2 are from viscosity discrimination experiments where the difference in stimulus pair was 10% and 25%, respectively. The plots in Figures 8.3 and 8.4 are for the mass discrimination experiments where the corresponding stimulus pair differences were 10% and 40%. In all graphs, two functions are plotted for each subject. Functions plotted with 'o' are average ramp functions for the reference stimulus and functions plotted with '+' represent the comparison stimulus results. Since both stimuli are presented an equal number of times during an experimental run, each function is an average of 32 trials of force data.

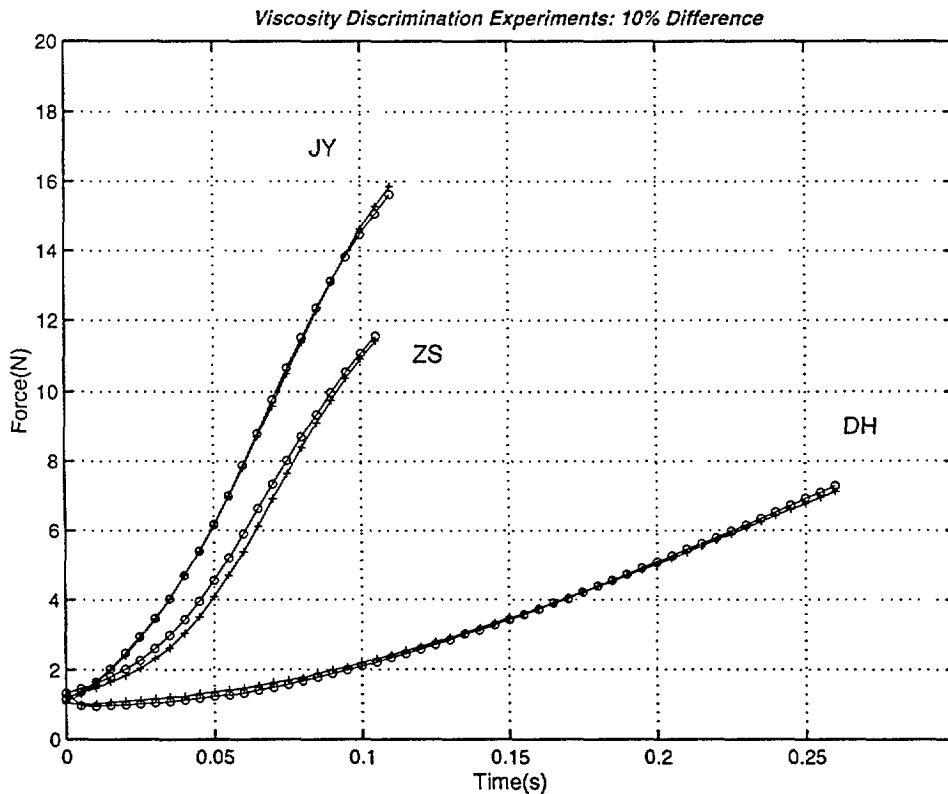

Figure 8.1: Typical Average Force Ramps for $\Delta B/B_0 = 10\%$

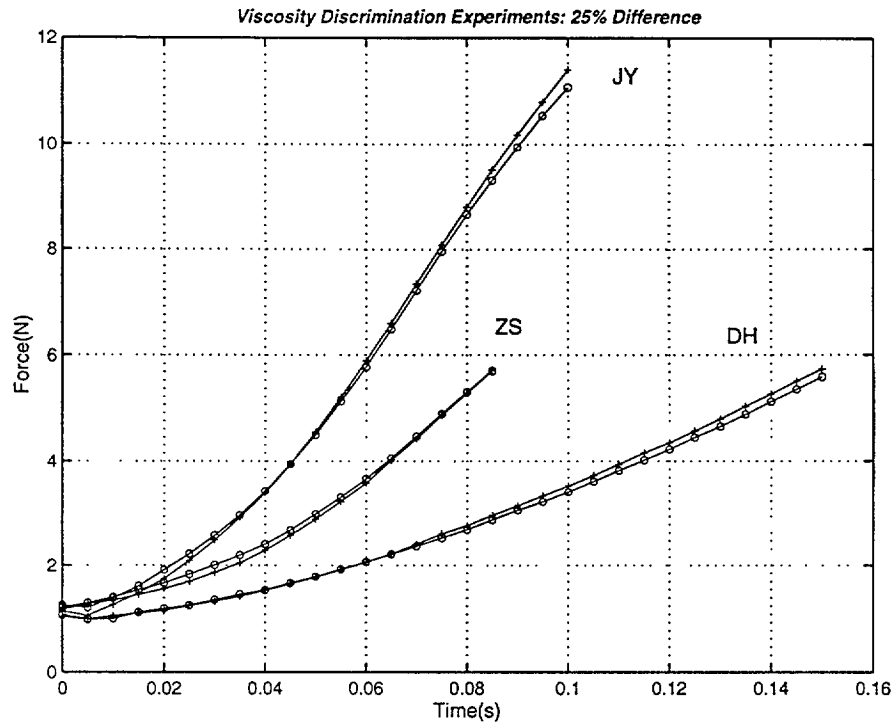

Figure 8.2: Typical Average Force Ramps for $\Delta B/B_0 = 25\%$

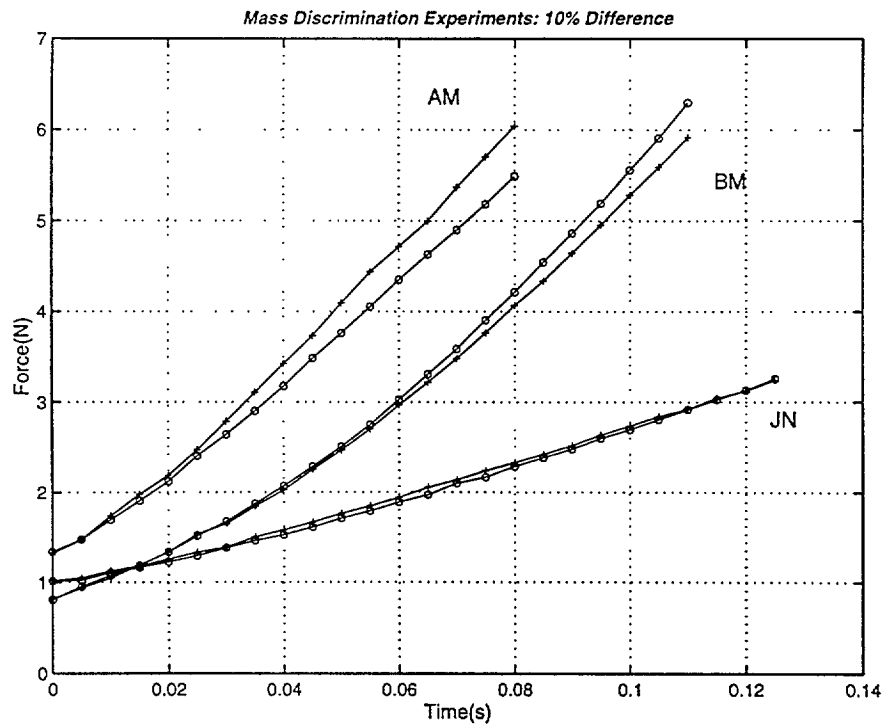

Figure 8.3: Typical Average Force Ramps for $\Delta M/M_0 = 10\%$

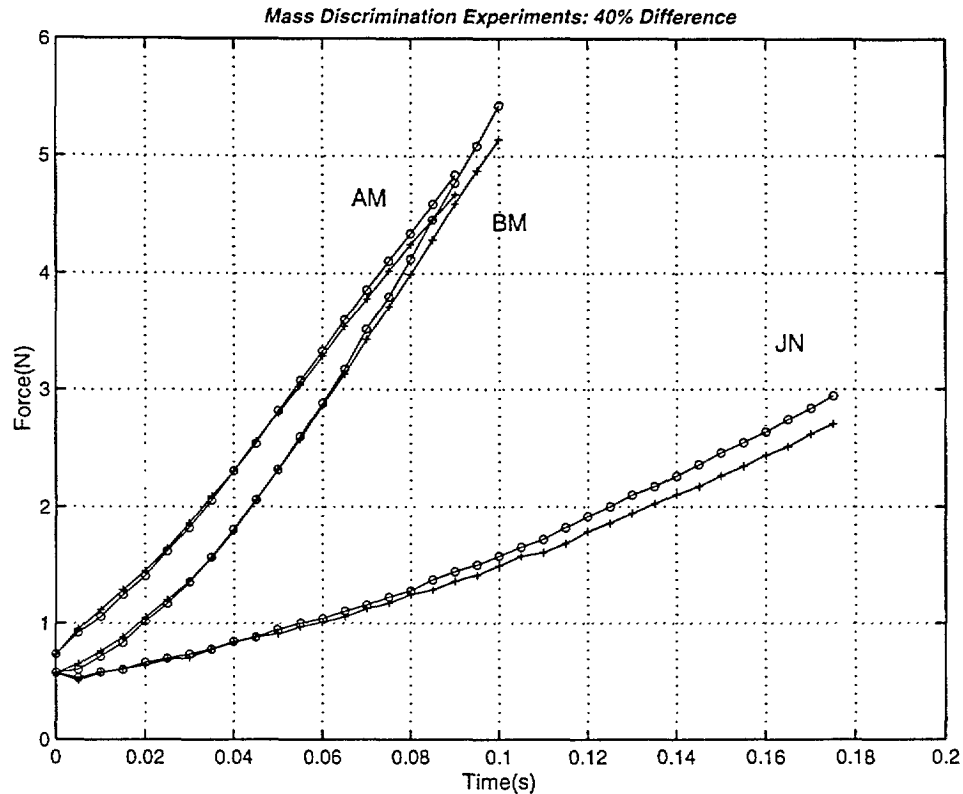

Figure 8.4: Typical Average Force Ramps for $\Delta M/M_0 = 40\%$

The figures indicate that different subjects squeeze with different force rates. But more importantly, the plots show that each of the subjects applies approximately the same grasping force ramp with respect to time to both stimuli. To ascertain if this was the case throughout the experiments, the percent difference in mean force for both stimuli during the force ramp was determined¹. The results are presented in Table 8.1 for both discrimination experiments by subject and stimulus pair. The data confirm that the difference in average applied force for the reference and comparison during this initial force ramp was very small and independent of stimulus pair. In fact the difference in mean force for the reference and comparison during the force ramp is typically much less than previously measured force JNDs (Pang et al, 1991). The conclusion is that on average,

¹ Since the same threshold force and time period was used for both stimuli, the percent difference in mean force would reflect any differences in the slopes of the force ramps.

each of the *subjects applied almost identical temporal force profiles for each of the reference and comparison stimulus pairs* presented in the viscosity and mass discrimination experiments.

$\Delta B/B_0$	JY	ZS	DH	$\Delta M/M_0$	AM	BM	JN
10%	2.2%	-0.3%	-1.2%	10%	-0.6%	-0.3%	-1.0%
15%	-1.8%	-1.7%	0.6%	20%	1.4%	-1.3%	1.4%
20%	3.0%	0.4%	3.1%	30%	2.9%	2.6%	-0.1%
25%	-1.0%	-0.7%	6.4%	40%	-2.5%	4.6%	1.3%
AVG	0.6%	-0.6%	2.2%	AVG	0.3%	1.4%	0.4%

Table 8.1: *Percent Difference In Mean Ramp Force between Reference and Comparison Stimuli.*

8.2.2 Force Ramps are Substantially Linear with Respect to Time

Regression analysis was performed on the force ramp data. For all subjects, it was found that the force ramp data could be reasonably well approximated by a first order linear time function, $f = \alpha t + c$, where the variables α and c , are constant with respect to time for a particular trial. The results are illustrated for Subject ZS in Figure 8.5, where raw force ramp data is plotted with 'o' and '+' denoting reference and comparison stimulus respectively, and the solid lines represent the best fit straight line determined through regression analysis. The figure suggests that the approximation is reasonable, though there is variability in α and c among trials.

Statistically, the closeness of the raw ramp force data points to the regression line was measured by calculating R^2 , the square of the correlation coefficient. The results are presented in Table 8.2 for both experiments. The results show that the force ramp is linear in time to an accuracy greater than 99%. Therefore it is quite reasonable to model the

subjects' initial grasp strategy as a linearly increasing force ramp.

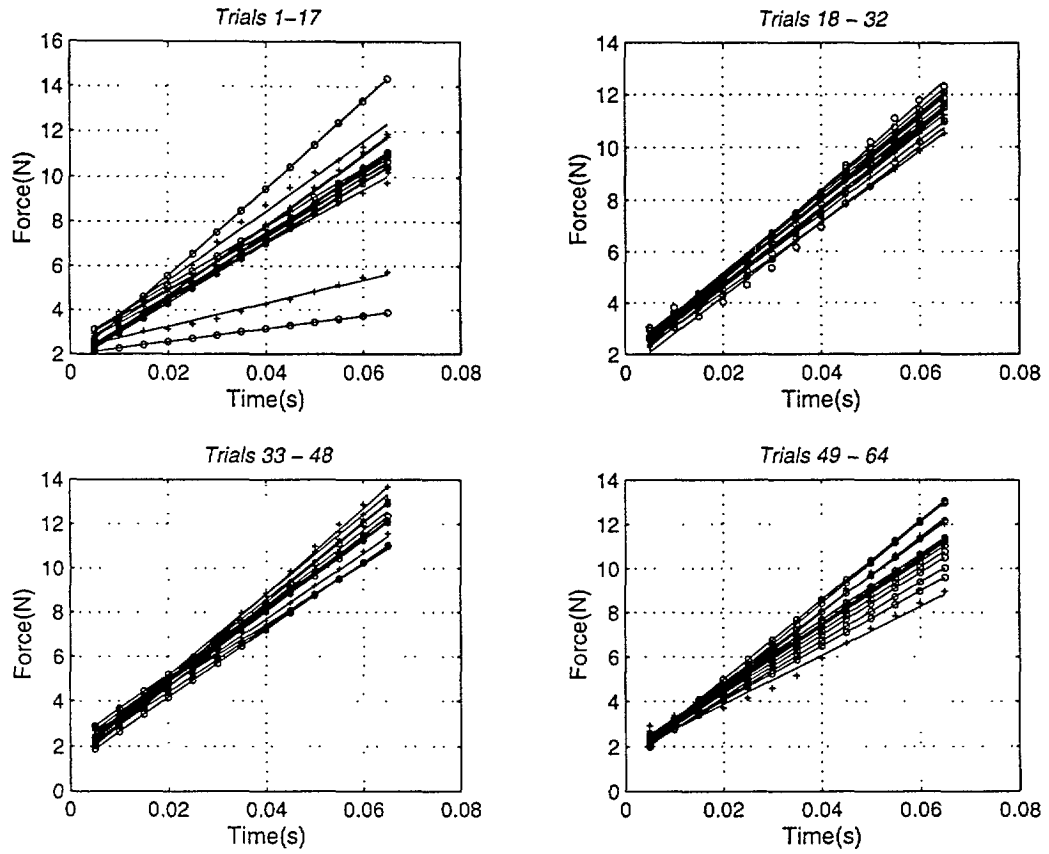

Figure 8.5: Typical Force Ramp Data for Subject ZS with Best fit Linear Regression

$\Delta B/B_0$	JY	ZS	DH	$\Delta M/M_0$	AM	BM	JN
10%	.9983	.9928	.9934	10%	.9978	.9964	.9965
15%	.9899	.9911	.9942	20%	.9984	.9969	.9923
20%	.9796	.9943	.9925	30%	.9983	.9969	.9975
25%	.9963	.9947	.9921	40%	.9974	.9974	.9946
AVG	0.9910	0.9932	0.9931	AVG	0.9980	0.9969	0.9952

Table 8.2: R^2 Values for Linearity of Force Ramp Data

8.3 A Theory on Active Pinch Grasp Discrimination

To summarize the motor and sensory results so far:

- (1) Over an experimental run, the subjects applied linear force ramps with respect to time to all stimuli. In addition, these force ramps, were on average, identical for each reference and comparison stimulus pair.
- (2) The JND for viscosity was 12% and the JND for mass was 20%; the JND for velocity was 11% and the JND for acceleration was 17%.
- (3) Anecdotally, many subjects reported that discriminated on the basis of “resistance”, “resistive force” and “viscous force” in the viscosity discrimination experiments and on the basis of “heaviness”, “weight” or “inertia” in the mass discrimination experiments. Additionally, subjects reported that when their performance was optimal (percent correct scores were high), subjects could discriminate the stimuli during the “initial grasping” of the object.

In the rest of the section, a simple theory is developed and a hypothesis proposed to explain the relationship between these results.

8.3.1 An Initial Grasp Premise

The experiments were designed so that the presentation order of the stimuli could not be predetermined by the subjects. Therefore further analysis is based on the following premise: *Given, that a subject does not know beforehand what the stimulus will be, the subject will attempt, on average, to use a similar initial grasp action for every trial.* In other words, for any trial, if a subject does not know what stimulus will be presented, there is no reason to apply an initial grasp action that will be different than that used for any other trial. This premise does not attempt to define what this initial grasp action is in terms applied force, motion, distance or time or even that all subjects will have the same

initial grasp action. It only indicates that the subjects will attempt to use a similar grasping strategy for all the trials of an experimental run.

8.3.2 Constraints on the Initial Grasp Strategy

Because, for any given trial, subjects will encounter an object with an unknown mechanical impedance, they cannot initially control the force-displacement relationship without some amount of sensory feedback. The same holds true for any velocity-displacement, acceleration-displacement, velocity-time, or acceleration-time relationship. However it is possible for the subjects to initially grasp with a force-time profile that is independent of the specific impedance encountered on any given trial.

Based on the force data presented in the previous section, this appears to be what the subjects are attempting to do during the discrimination experiments. Specifically, the data suggests that throughout both the viscosity and mass discrimination experiments, the initial grasp action that the subjects used can be well described as a force ramp that is linearly increasing in time. Additionally, while there is variability in the slope of the force ramp over the course of the experimental run, on average, the same force ramp is used for both reference and comparison stimuli.

8.3.3 Implications of Linear Temporal Force Ramp Model

Applying a linearly increasing force ramp with respect to time has ramifications on the distribution of force with respect to the distance squeezed. In fact, the *same* $f(t)$ for different viscosity and mass stimuli will result in a *different* $f(x)$ for each stimulus. The same is true for velocity and acceleration with respect to distance. The relationships are expressed mathematically below:

Assumption:

Subjects apply the force profile over time for all trials and that force profile can be modeled as:

$$f(t) = \alpha t$$

where,

$$\alpha = \text{constant} > 0,$$

$$t > 0.$$

Implications:

For viscosity:

$$f(t) = B\dot{x} = \alpha t$$

where, $B =$ reference stimulus;

Thus,

$$v(t) = f(t) / B = \alpha t / B$$

where,

$v(t)$ is velocity for the reference stimulus.

Therefore,

$$x(t) = \int_0^t \frac{f(\tau)}{B} d\tau = \frac{\alpha t^2}{2B}$$

where,

$x(t)$ is position as a function of time.

Therefore time, t , can be expressed as the following function of position:

$$t(x) = \sqrt{\frac{2Bx}{\alpha}}$$

As a result, the spatial force profile is:

$$f(x) = \sqrt{2\alpha Bx}$$

Likewise, it can be shown that the spatial force profile, $f - \Delta f$, for a comparison stimulus, $B - \Delta B$, is:

$$f(x) - \Delta f(x) = \sqrt{2\alpha(B - \Delta B)x}$$

Finally, the **percent difference in the force profiles at any distance** (i.e. at any fixed value of x) for the two stimuli is:

$$\boxed{\frac{\Delta f}{f} = 1 - \sqrt{\frac{B - \Delta B}{B}}}$$

Likewise, this analysis can also be done with respect to velocity, the resulting **percent difference in the velocity profiles at any distance** for the two stimuli is:

$$\boxed{\frac{\Delta v}{v} = 1 - \sqrt{\frac{B}{B - \Delta B}}}$$

where $v + \Delta v$, is the velocity for the comparison stimulus.

The same analysis can be performed when the stimulus is a *mass*,

Let M = reference mass,

Thus,

$$a(t) = f(t) / M = \alpha t / M$$

where,

$a(t)$ is acceleration for the reference stimulus.

Therefore,

$$v(t) = \int_0^t \frac{f(\tau)}{M} d\tau = \frac{\alpha t^2}{2M}$$

where,

$v(t)$ is velocity as a function of time.

Finally,

$$x(t) = \int_0^t v(\tau) d\tau = \frac{\alpha t^3}{6M}$$

where,

$x(t)$ is position as a function of time.

Therefore time, t , can be expressed as the following function of position:

$$t(x) = \sqrt[3]{\frac{6Mx}{\alpha}}$$

As a result, the spatial force profile is:

$$f(x) = \sqrt[3]{6\alpha^2 M x}$$

Likewise, it can be shown that the spatial force profile, $f - \Delta f$, for a comparison stimulus, $M - \Delta M$, is:

$$f(x) - \Delta f(x) = \sqrt[3]{6\alpha^2 (M - \Delta M)x}$$

It can be shown from above that the **percent difference in the force profiles at any distance** for the two stimuli is:

$$\frac{\Delta f}{f} = 1 - \sqrt[3]{\frac{M - \Delta M}{M}}$$

Likewise, this analysis can also be done with respect to acceleration. The resulting **percent difference in acceleration profiles at any distance** for the two stimuli is:

$$\frac{\Delta a}{a} = 1 - \left(\frac{M}{M - \Delta M} \right)^{2/3}$$

where $a + \Delta a$, is the acceleration for the comparison stimulus.

8.3.4 Possible Discrimination Hypotheses Consistent with the Motor Data

Thus, the mathematical model indicates that applying the same linear force ramp in time for all stimuli gives rise to specific force and motional cues with the respect to distance. The magnitude of the cues (in other words, the percent difference in the spatial profiles for the force, velocity and acceleration) depends solely on the ratios of the stimuli presented in the experiment. To determine which, if any, of these cues are sufficient to explain the viscosity and mass JND results, the following discrimination strategies are hypothesized:

Possible Hypotheses:

Subjects apply a stereotypical force profile, $f(t)=at$, for both the reference and comparison stimulus and discriminate on the basis of corresponding differences in (1) force, (2) velocity or (3) acceleration averaged over distance.

To determine if any of these hypotheses explain the measured viscosity and mass JND results, theoretical JND predictions based on force, velocity and acceleration values averaged over distance were calculated using the model. The theoretical JNDs were calculated by determining the difference in stimulus pair that would result in a percent difference in force, velocity and acceleration equal to the JND data for those cues. For example, below are the formulas used to predict the viscosity and mass JNDs based on force discrimination:

Using the model to solve for $\Delta B/B$ and $\Delta M/M$ in terms of percent difference in force gives rise to the following two equations:

$$\frac{\Delta B}{B} = 1 - \left(1 - \frac{\Delta f}{f}\right)^2 = 2 \frac{\Delta f}{f} - \left(\frac{\Delta f}{f}\right)^2$$

$$\frac{\Delta M}{M} = 1 - \left(1 - \frac{\Delta f}{f}\right)^3 = 3 \frac{\Delta f}{f} - 3\left(\frac{\Delta f}{f}\right)^2 + \left(\frac{\Delta f}{f}\right)^3$$

Substituting the percent difference in force ($\Delta f / f$), with force JND data yields theoretical JND values for viscosity and mass. Furthermore, because force JNDs are in the range of 5–10%, we can simplify these equations by eliminating the second and third order terms and are left with the following approximations:

$$\frac{\Delta B}{B} \cong 2 \frac{\Delta f}{f}$$

$$\frac{\Delta M}{M} \cong 3 \frac{\Delta f}{f}$$

Thus the model predicts the JND for viscosity to be approximately *double* the JND for force and the mass JND to be *triple* the force JND. Or conversely,

$$\frac{\Delta f}{f} \cong \frac{\Delta B}{2B} \cong \frac{\Delta M}{3M}$$

Similar calculations were performed for velocity and acceleration. The force-based predictions utilized force JND data from Pang et al, 1989. (Pang et al, 1989, used the same device and experimental procedure employed in this thesis.) The velocity-based and acceleration-based predicted JNDs are calculated using the velocity and acceleration JND data presented in Chapter 7. The predictions are presented in Table 8.3 along with the experimentally measured JND values for viscosity and mass.

<i>Object Property</i>	<i>Measured JND</i>	<i>Predictions Based on Force Discrimination</i>	<i>Predictions Based on Velocity Discrimination</i>	<i>Predictions Based on Acceleration Discrimination</i>
Viscosity	Average: 12% Range: 7 - 19%	13.5% 10 - 19%	19% 18 - 20%	17% 14 - 20%
Mass	Average: 20% Range: 14 - 27%	20% 16 - 25%	27% 25 - 29%	24.5% 20 - 29%

Table 8.3: Actual versus Predicted JND Results

The data shows that theoretical JND values based on velocity discrimination predict noticeably higher JNDs than were measured for viscosity and mass. The acceleration discrimination hypothesis predicts the measured JND results for mass reasonably well, but predicts higher JNDs for viscosity than were measured. However, the theoretical JND predictions from the force based discrimination strategy closely match both the average and range of the measured JND results for viscosity and mass discrimination experiments. In addition, a discrimination strategy based on force cues are consistent with the anecdotal observations by most of the subjects that they discriminated on the basis of “resistance”, “resistive force”, “viscous force”, “heaviness” and “inertia”.

The comparison of these actual and predicted JND results are also presented graphically in Figures 8.6 and 8.7 for the viscosity and mass discrimination experiments.

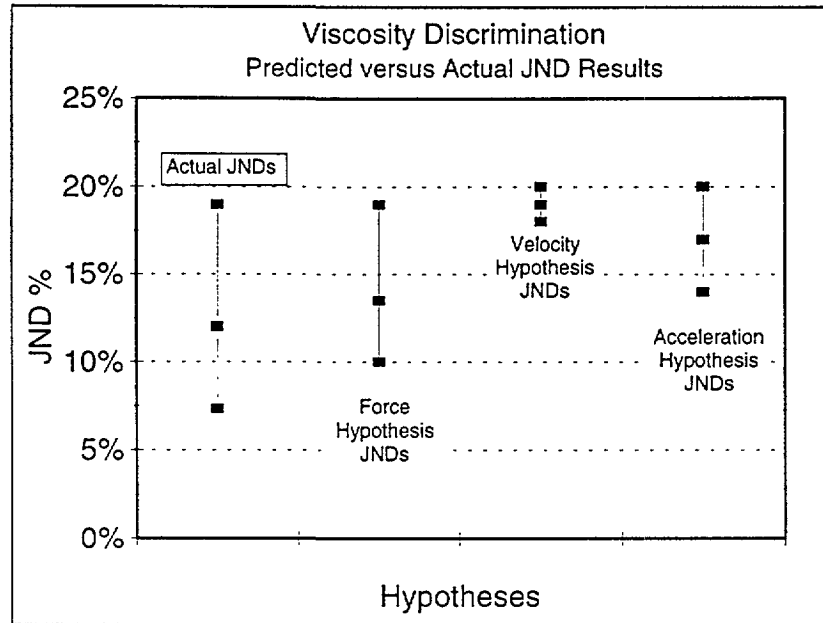

Figure 8.6: Actual versus Predicted JND Results for the Viscosity Discrimination Experiments

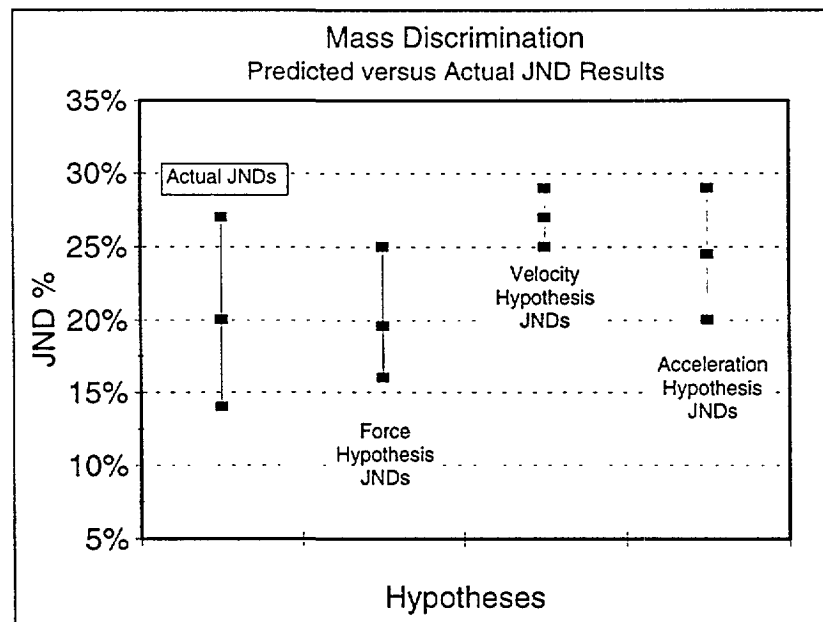

Figure 8.7: Actual versus Predicted JND Results for the Mass Discrimination Experiments

8.3.5 The Temporal Force Control–Spatial Force Discrimination (TFC–SFD) Hypothesis for Active Touch Discrimination

The following sensorimotor strategy is hypothesized to explain all the results of the viscosity and mass discrimination experiments:

Temporal Force Control–Spatial Force Discrimination (TFC–SFD) Hypothesis:

Subjects apply a temporally controlled force, $f(t)=at$, and discriminate on the basis of a resulting spatial distribution of force that is determined by the specific mechanical properties of the object being grasped.

This hypothesis is based on the recorded motor data for the subjects, explains the measured viscosity and mass JND results for each of the subjects and is consistent with the anecdotal observations of the subjects. In essence, the hypothesis postulates that the “effort” subjects apply in grasping the stimulus can be effectively modeled as a linear force ramp with respect to time. The mechanical properties of the stimulus transform this “effort” into a corresponding spatial force function that is perceived as the viscous force or inertia of the stimulus.

8.3.6 Implications of the Theory

This point is illustrated in Figure 8.8 for subject ZS. The graph in this figure contains force versus distance plots for all 64 trials of an experimental run where the difference in the stimulus pair was 25%. Solid lines represent trials where the stimulus was the reference and dotted lines represent trials where the comparison was the stimulus. The difference in the average slope of force ramp profiles *over time* for both stimuli was less than 1.0% for this experimental run. However, each stimulus influences the *spatial* force mapping differently and according to the model for viscosity, this difference is linearly related to the square root of the ratio of the reference and comparison stimuli. The result, seen graphically in Figure 8.8, is that at any fixed position, the force for the comparison stimulus is generally less than that for the reference stimulus.

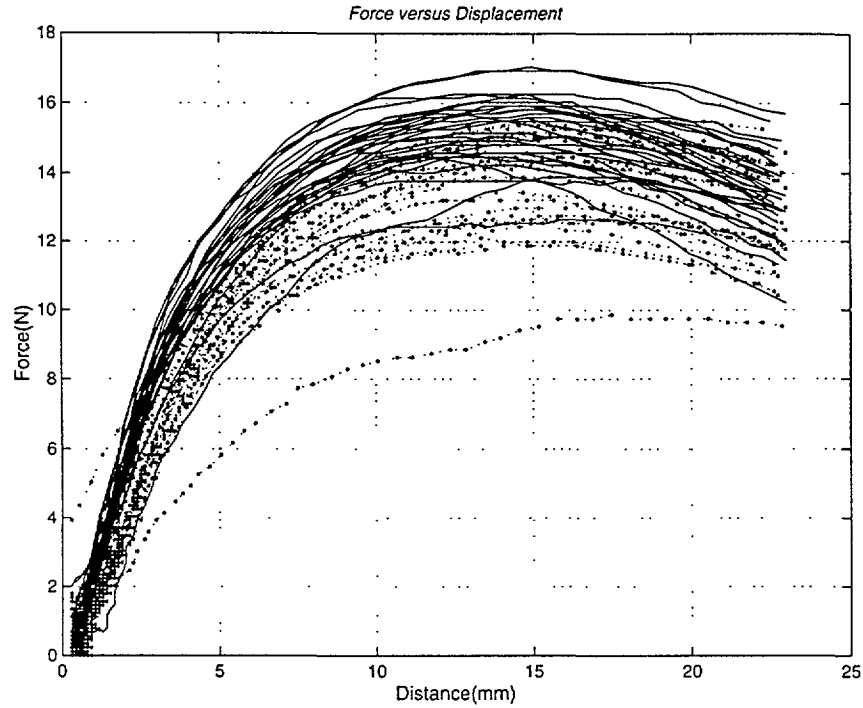

Figure 8.8: *Force versus Displacement Data for $\Delta B/B_0 = 25\%$*

To quantify the observation that force cues are available early during the pinch grasp, in Table 8.4, the spatial mean force difference for all stimulus pairs is calculated over the first 10 mm of distance. The data was calculated by averaging force with respect to distance in the same fashion as was employed in Chapters 5 and 6 to determine the average mean force results over the entire fixed displacement. The results in the table confirm that spatial-based force cues are available during this initial grasping of the object.

Stimulus Pair		Average Mean Force Difference
<i>Viscosity</i>	<i>10%</i>	<i>5.3%</i>
	<i>15%</i>	<i>8.1%</i>
	<i>20%</i>	<i>12.8%</i>
	<i>25%</i>	<i>14.6%</i>
<i>Mass</i>	<i>10%</i>	<i>3.0%</i>
	<i>20%</i>	<i>8.2%</i>
	<i>30%</i>	<i>10.1%</i>
	<i>40%</i>	<i>16.2%</i>

Table 8.4: *Mean Spatial Force Differences for the first ten millimeters*

Based on the TFC-SFD Hypothesis, the reason that subjects are better at discriminating viscosity than mass is because the same grasp strategy, $f(t) = \alpha t$, results in greater differences in the spatial force functions for viscosity than mass for the same stimulus pair difference. This can be extended to include compliance discrimination. For any compliance, C , position and time are directly related and the percent difference in force cues is equal to the stimulus pair difference. A comparison of the spatial mean force difference data for viscosity, mass, and compliance is shown in Figure 8.9, where the spatial mean force difference data for these three mechanical properties are plotted versus stimulus pair. For viscosity and mass, the solid lines in the plot are the best fit straight lines for the spatial mean force results. The actual data, averaged over all subjects, is plotted as dark squares for the viscosity results and as gray circles for the mass results. The theoretical force data for compliance is depicted as a dotted line.

For all stimulus pair differences with viscosity and mass, the spatial mean force difference between the reference and comparison stimuli is the greater for viscosity than for mass. Furthermore, when the difference in stimulus pair is equal to the viscosity and mass JND (indicated by the vertical black lines for viscosity and mass) the percent difference in spatial mean force approaches the force JND of 7% reported by Pang, et al, 1989. Likewise for compliance, when the difference in stimulus pair approaches compliance JND (as reported by Tan et al, 1995, using the same device and experimental paradigm), the percent difference in spatial mean force also approaches the force JND. Thus, the TFC-SFD hypothesis provides a mechanism to explain the loss in sensory resolution that occurs when force cues become dependent on derivative based displacement cues.

The hypothesis does not state whether the subjects measure the mechanical impedance of the stimulus as an averaged spatial force function or as an integrated spatial force function. However, research by others (Pang et al, 1989; Tan et al, 1995) involving constant force and compliance discrimination has showed that force integrated over distance, in other words mechanical work, greatly influences discrimination judgment.

The possibility that mechanical work or force is the underlying factor for all these discrimination experiments is discussed in more detail in Chapter 9.

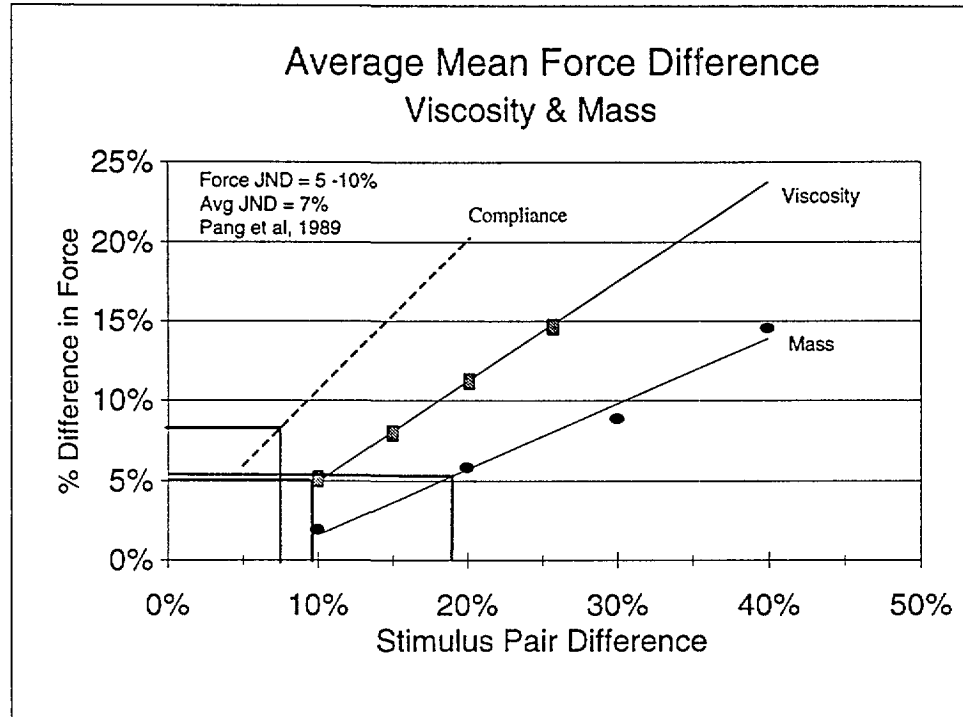

Figure 8.9: A Comparison of the Spatial mean Force Differences for Viscosity and Mass

8.3.7 Modifications to the Theory

The theory is based on the idealization that subjects apply the same force ramp ($f(t)=\alpha t$, where α is a constant) for all trials. However the coefficient of variation data for force presented in Chapters 5 and 6, indicates there is variability in the applied force from trial-to-trial. A histogram of the slope (α) values in Figure 8.11 reinforces this fact. In this figure, slope data for 256 trials is presented for subject ZS from every experimental run where the reference viscosity was 120Ns/m and the stimulus pair difference was 25%. The data shows a range of slope values from 40–160N/s for both stimuli with majority of values clustered around 120N/s. (The standard deviation in the slope data for both stimuli was approximately 25N/s.) When the mean slopes were calculated for the reference and comparison stimuli, the difference in the means was only 2.2%. Therefore, although the

range of slopes is quite large, the implication is, that distributions are nearly the same for both stimuli and on average, the same force ramp is used for both stimuli. This fact is further supported by the data in Table 8.1, where the percent differences in spatial mean ramp force data are presented for all stimulus pairs.

Therefore what the theory actually captures is the overall statistical nature of the motor data and $f(t) = \alpha t$ more accurately describes the mean applied force ramp of the reference and comparison stimuli than the applied force ramp for every individual trial.

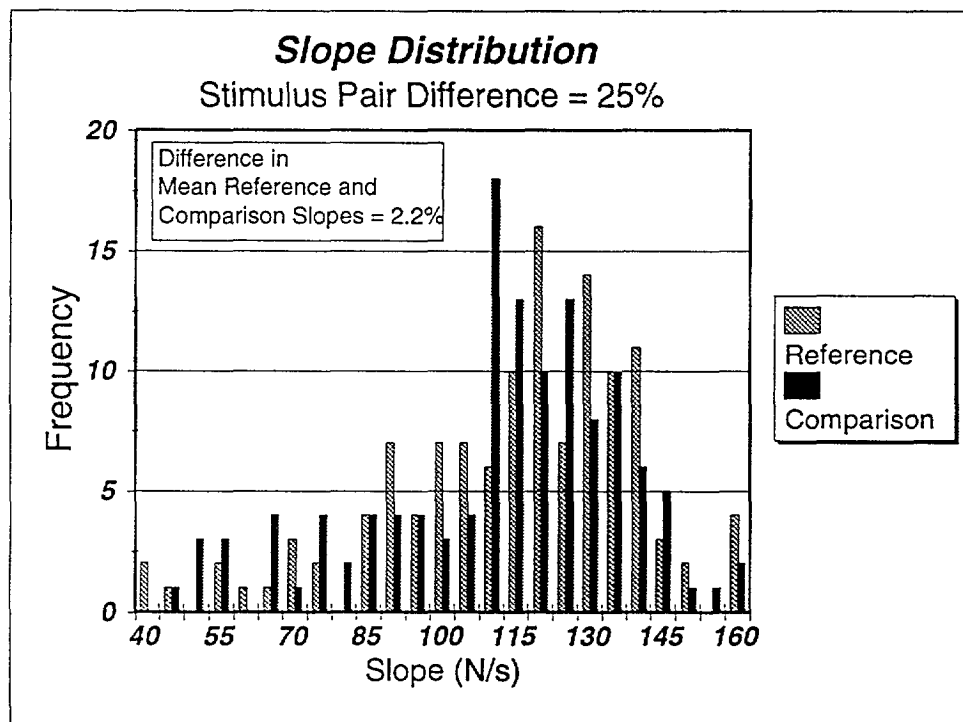

Figure 8.10: The Distribution of Slope Data for Subject ZS when $\Delta B/B_0 = 25\%$

8.3.8 Model Predictions for Force and Motional Data

The model predicts that the average percent differences in spatial force, velocity and acceleration profiles depend primarily on the ratios of the stimuli involved in the experiment. For the viscosity discrimination experiments, the spatial mean force percent differences are linearly related to the square root of the ratio of the comparison to the reference viscosity. Whereas, spatial mean velocity differences are linearly related to the

square root of the ratio of the reference to the comparison viscosity. In the mass discrimination experiments, the differences are determined by powers of the cube root of the ratio of the masses: spatial mean force differences are linearly related to the cube root of the ratio of the comparison mass to the reference mass and spatial mean acceleration differences are linearly related to the square of the cube root of the ratio of the reference mass to the comparison mass.

To confirm that the model works reasonably well in describing this data, we can compare model predictions for the percent difference in force, velocity and acceleration with actual data. Because the model is only applicable for the ramp portion of force profile, the actual percent differences were determined over the first 10 millimeters of travel, because typically the linear force ramp was used in this displacement range.

The results of this analysis are presented versus stimulus pair in Figures 8.11–8.14. Predicted values are plotted for force and velocity in Figures 8.11 and 8.12 for the viscosity discrimination experiments along with the actual spatial mean data from these experiments. Similarly, predicted values are plotted for force and acceleration in Figures 8.13 and 8.14 for the mass discrimination experiments along with the actual spatial mean data from these experiments. Overall, the plots verify that a good match between the predicted and actual values exists. The predicted increase in force and motion cues as the difference in stimulus pairs increases is corroborated with the actual data for both the viscosity and mass discrimination experiments.

Incidentally, the model also provides a partial explanation as to why the spatial mean force differences presented in Chapters 5 and 6 (which were also spatial averages) increased with stimulus pair difference. Although in these cases, because the averages were over the entire fixed distance of 25 mm (and not just the first 10 mm), minor discrepancies between the model and the data arise. This is because after the first 10 mm subjects often exhibited some plateauing and reduction in their applied force profiles over the remaining distance that is not accounted for in the model.

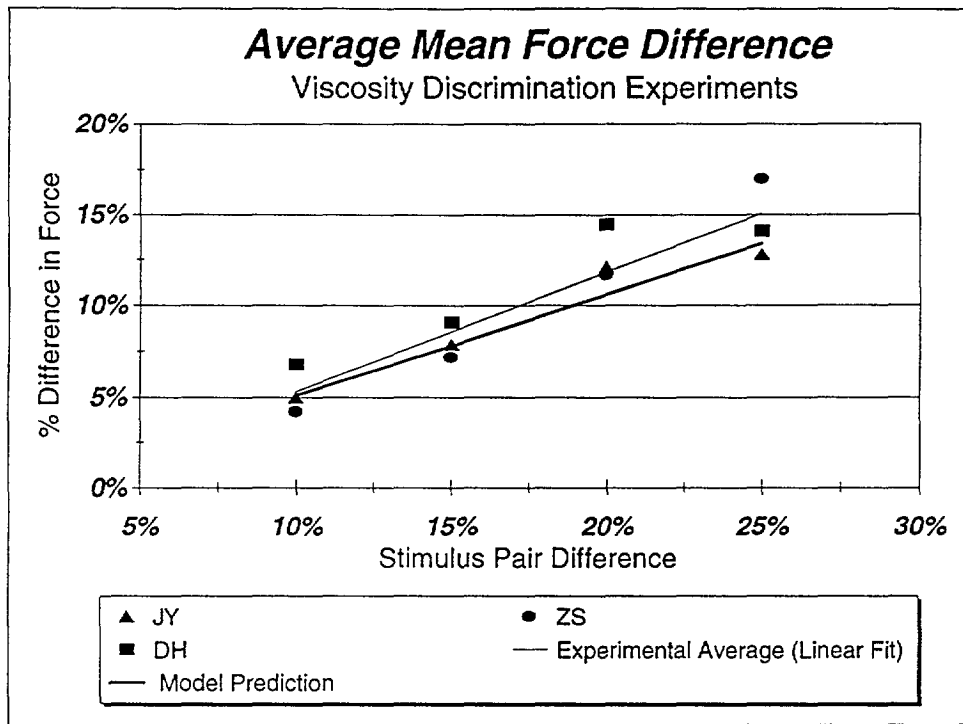

Figure 8.11: Actual versus Predicted Spatial Mean Force Results

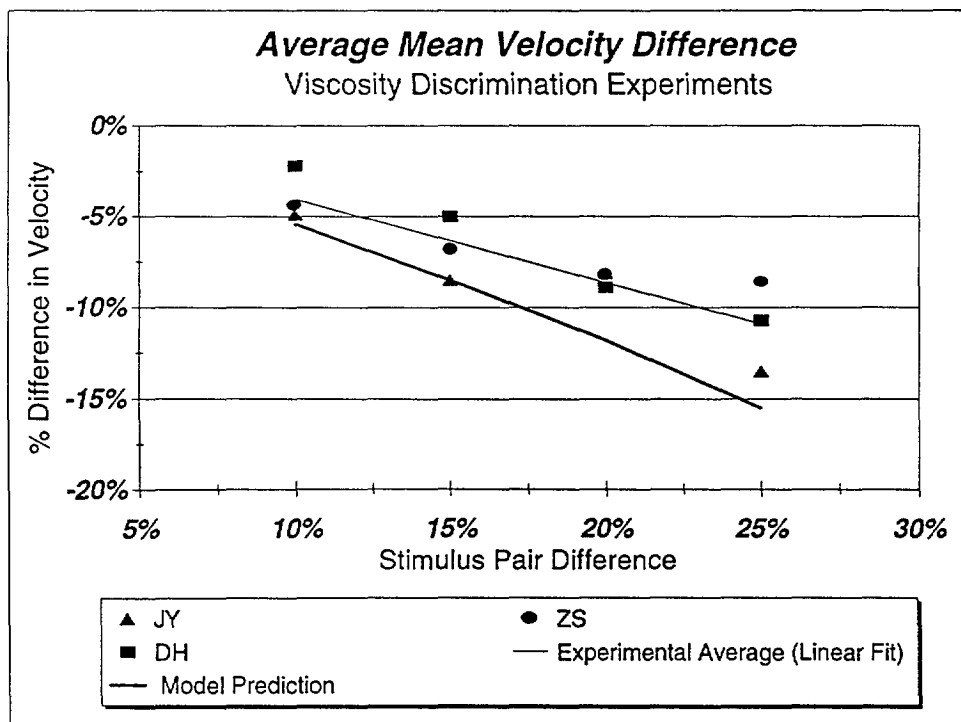

Figure 8.12: Actual versus Predicted Spatial Mean Velocity Results

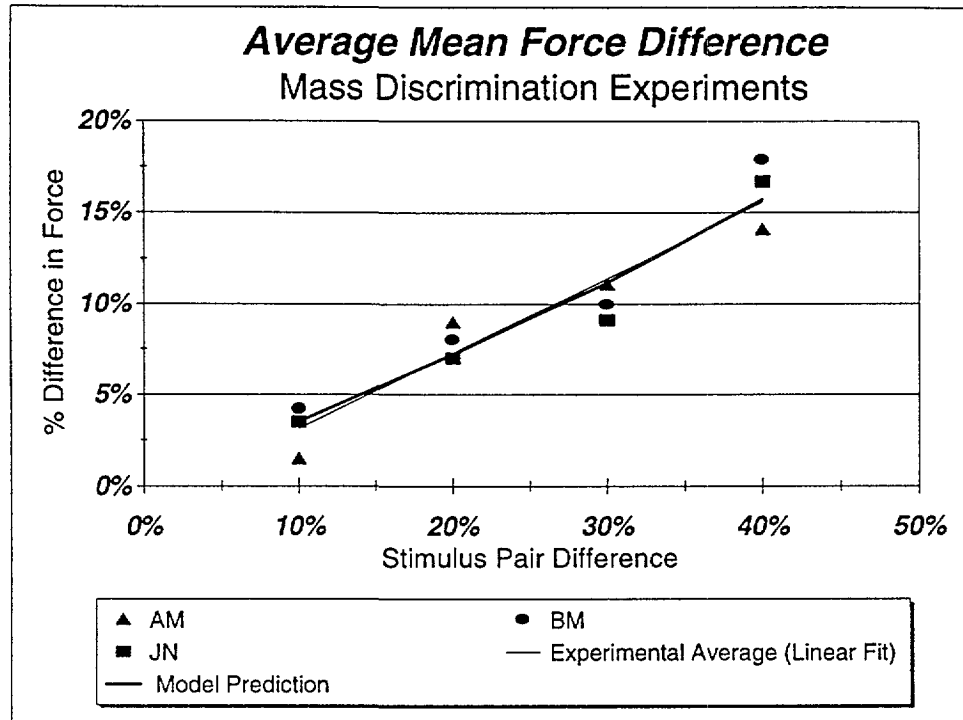

Figure 8.13: Actual versus Predicted Spatial Mean Force Results

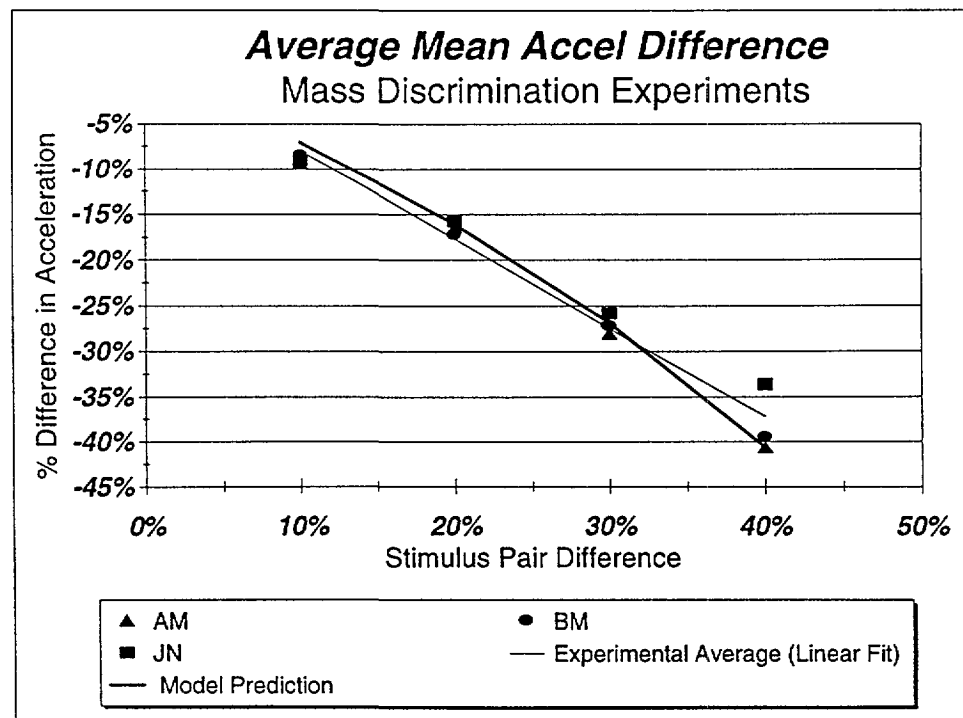

Figure 8.14: Actual versus Predicted Spatial Mean Acceleration Results

8.4 Analysis of Coefficient of Variation Data

A summary of the overall force coefficient of variation results for the discrimination experiments are presented in Table 8.5. Because motor performance was recorded for only 400 trials in the fixed displacement viscosity discrimination experiments, coefficient of variation results for this experiment are not included in the table. The results in the table are a measure of the average variation in mean force for both the reference and comparison stimulus over the course of an experimental run. The data suggest that for both the viscosity and mass experiments, the mean forces for both stimuli exhibited comparable amounts of variation when measured as a percentage of average mean force. The average coefficient of variation for the viscosity experiments was 10.7% versus 16.3% for the mass discrimination experiments. Thus, there was less variation in mean force over the course of an experimental run involving viscous stimuli, than an experimental run involving mass stimuli.

Experiment	Coefficient of Variation: Reference	Coefficient of Variation: Comparison
Viscosity Discrimination	<i>10.1%</i>	<i>11.3%</i>
Fixed Displacement Mass Discrimination	<i>15.6%</i>	<i>15.0%</i>
Different Reference Mass Discrimination	<i>17.4%</i>	<i>17.1%</i>

Table 8.5: Overall Coefficient of Variation Results

Since these results measure the coefficient of variation over an experimental run, they do not necessarily characterize the trial to trial performance by the subjects. Given, that subjects are supplied with correct response feedback after every trial, there is a significant likelihood that their decision strategy involves the comparison of two consecutive trials, therefore variability in applied mean force between two consecutive trials may provide a better indication of motor performance consistency than measuring the coefficient of variation over the entire experimental run. Further, to eliminate

variations in force due to differences in the stimuli for consecutive runs, it is more useful to measure the coefficient of variation for consecutive trials involving the same stimuli.

Results of this analysis are presented in Table 8.6 for subjects for which consecutive trial data existed. Shown is both mean and median trial-to-trial coefficient of variation data for applied force when same stimuli were presented on consecutive trials. For each subject, the average mean value was calculated by averaging the mean coefficient of variation data from every experimental run. Likewise, the average median value was determined by averaging the median data from every experimental run. (The median is the middle score of a distribution of data.)

Experiment	Subject	Mean Trial-to-Trial Coefficient of Variation	Median Trial-to-Trial Coefficient of Variation
	JY	6.7%	4.6%
Viscosity	ZS	7.8%	5.3%
	DH	7.6%	5.0%
	<i>Average</i>	7.4%	5.0%
	AM	8.6%	6.3%
Mass	BM	10.1%	7.4%
	JN	12.3%	8.1%
	<i>Average</i>	10.4%	7.3%

Table 8.6: Trial-to-Trial Force Variation Results

The data indicate that the average trial-to-trial variations in mean force are generally equal to the force JND values as measured by Pang, et al 1991. Consistent with coefficient of variation results over an entire experimental run, the mean trial-to-trial variation for the viscosity discrimination experiments was less than that for the mass discrimination experiments (7.4% versus 10.4%). However, the difference between the two experiments is much smaller when measured from trial-to-trial.

The median results were always lower than the mean results. This indicates that the coefficient of variation between any two consecutive trials was more likely than not to

be less than the mean for that experimental run. In fact, for the viscosity discrimination experiments, nearly 70% of the time the coefficient of variation between consecutive trials was less than the mean of 7.4%. Hence, for most of the trials, the variation in mean applied force was less 5.0%. A similar analysis of the mass discrimination experiments indicates that greater than two-thirds of the time the coefficient of variation was less than the mean of 10.4%.

Thus, there appears to be two types of variation during an experimental run: (1) Variability that arises between trials that is approximately equal to the JND for force and, (2) A variation in mean applied force that occurs more gradually over the entire course of an experimental run, and is greater than the average trial-to-trial variation. Since in the first case the variation was often less than or equal to force JND, then it is quite possible that motor performance variability had only a small impact on the discrimination performance.

9

Discussion

9.1 Summary of Results

The objective of this research has been to study how the haptic system discriminates physical properties of objects through the mechanism of active touch. To accomplish this objective, this thesis has focused on studying the capability of the haptic system to discriminate two elemental physical properties, viscosity and mass, with active pinch grasping. In regards to these properties, the investigation has sought to accomplish three goals: (1) To measure discrimination performance under various conditions, (2) To obtain human factors data on the applied forces, velocities and accelerations used during active pinch grasp discrimination, and (3) To characterize the haptic motor strategies utilized in discrimination tasks with emphasis on exploring how motor performance and underlying sensory limits may affect discrimination performance.

In regards to measuring discrimination performance, JNDs for viscosity and mass have been measured for different references and squeezing distances. Overall, the average JND for viscosity has been found to be 12% and reasonably constant over a range of references (60–180Ns/m) and fixed squeezing distances (15–35mm). The average JND for mass was found to be 20% and likewise constant over a span of references (6–12kg) and similar fixed squeezing distances (15–35mm). When compared to a force JND of 7% and a compliance JND of 8% obtained under similar experimental conditions using the same device (Pang et al, 1991; Tan et al, 1995), these results show a loss in sensory

resolution when the resisting force of the object was proportional to derivative-based displacements. This degradation in discrimination performance is consistent with the results of Jones and Hunter (1989, 1992b, 1993), although our JNDs for compliance and viscosity were much less than theirs (8% and 12% versus 23% and 34%, respectively).

The mass JND results obtained in this thesis are in the range of Weber fractions, 16% - 30%, reported by Ross et al (1984) and are close to the differential sensory threshold for the moment of inertia of 28% measured by Kreifeldt and Chuang (1979). But the results are considerably less than the Weber fraction of 113% reported by Ross and Benson (1986) for moment of inertia.

To support an analysis of the how the sensorimotor interactions might influence the manual resolution of viscosity and mass, velocity and acceleration JNDs were measured over the range of velocities and accelerations experienced during the discrimination experiments. An average JND for velocity of 11% was measured for reference velocities ranging from 60–120 mm/sec and an average JND of 17% was measured for accelerations from 400–1600 mm/sec². These JNDs were measured under passive conditions (requiring no active effort from the subjects) and attempted to measure the purely sensory limits of the haptic system in discriminating these properties. Because the stimuli in these experiments were presented over the same fixed displacements used in the viscosity and mass discrimination experiments, it is possible that subjects discriminated on the basis of time to completion for velocity discrimination and terminal velocity or time to completion for acceleration discrimination. However, those cues would have also been available if subjects discriminated on the basis of velocity or acceleration during the viscosity and mass experiments and are thus potentially appropriate cues for the subjects to use. To fully characterize the manual resolution of velocity and acceleration, beyond what is necessary to study the mechanisms of viscosity and mass discrimination, it may be necessary to design experiments that mitigate these cues.

There are no other known studies that have reported data on the manual resolution of velocity and acceleration, thus these results cannot be directly compared to the results

of any other work. However, Milner (1986) has reported that the ability to accurately reproduce target peak velocities with rapid flexion of the interphalangeal joint of the thumb was degraded for half of his subjects when viscous loads were intermittently applied to the thumb. Thus, the ability to sense and control velocity may be influenced and degraded by the presence of viscosity, although there were only six subjects in Milner's experiment and each subject completed only a total of 80 movements.

In our experiments, haptic motor performance was recorded for 9,616 trials during the viscosity discrimination experiments and 11,280 trials during the mass discrimination experiments. During the viscosity experiments, average pinch grasp forces ranged from 3.5–17 Newtons depending on subject and stimulus. Resulting grasp velocities ranged from 35–195 mm/sec for the viscosity discrimination experiments. Average pinch grasp forces in the mass discrimination experiments varied from 3.5–7.5 Newtons with resulting accelerations from 350–1200 mm/sec². These human factors data compare to average forces of approximately 4–6 Newtons and velocities from 40–80 mm/sec for comparable viscous stimuli in contralateral matching experiments involving the forearms (Jones and Hunter, 1993) and pushing velocities from 20–120 mm/sec in active pinch grasp force discrimination experiments using the Linear Grasper (Pang et al, 1991).

The third emphasis of this study was to explore the relationship between discrimination and motor performance. Thus even though the number of subjects was limited, all subjects whose motor performance was analyzed completed a large number of trials (typically more than 3,000) to ensure an adequate amount of motor data (in terms of forces, velocities and accelerations) and discrimination data were acquired. A common observation for all experimental conditions was that the amount of force and motional cues available to the subjects, when averaged with respect to squeezing distance, varied systematically with the difference in stimulus pairs. In essence, it was observed that while the spatial mean force for the reference stimulus was *constant* for all stimulus pairs, the spatial mean force for the comparison *decreased* as the difference in stimulus pair *increased*. As a result, the difference in the spatial mean force between the reference and

the comparison increased as the difference in stimulus pair increased. In regard to motional cues, it was observed that while the spatial mean velocity in the viscosity discrimination experiments (or acceleration in the mass discrimination experiments) for the reference stimulus was *constant* for all stimulus pairs, the spatial mean velocity (or acceleration) for the comparison *increased* as the difference in stimulus pair *increased*. As a result, the difference in the spatial mean velocity (or acceleration) between the reference and the comparison also increased as the difference in stimulus pair increased.

It appears that these cues arose naturally from a propensity for all subjects to consistently apply a stereotypical force profile $f(t) = \alpha t$, when initially grasping the stimulus. This stereotypical force profile was transformed into a distinct mapping of force versus displacement by the mechanical impedance of the stimulus being grasped. The resulting JND performance for both viscosity and mass is then best explained by postulating that subjects discriminate on the basis of differences in the spatial force profiles of the two stimuli. Specifically, it was found that the JNDs for viscosity and mass occurred when the spatial mean force difference between the reference and comparison fell within the range of force JNDs measured by Pang et al (1991) under the similar experimental conditions.

The precise nature of what differences in the spatial force profiles subjects base their responses is unclear. Theoretically speaking, the JND results could be predicted equally well if subjects discriminated based on: (1) Differences in a single force value at one fixed displacement, (2) Differences in the average force over distance, or (3) Differences in an integrated force over distance function, like mechanical work. Although, (1) implies that subjects sample force at just one (and at always the same) fixed displacement and ignore all other force and motional information available during the trial. This makes performance depend also on the ability to manually resolve the same single fixed displacement for every trial and it is generally disadvantageous because it ignores additional force and displacement information available during grasping. Thus, it is less likely to be the actual strategy utilized by the subjects.

There is no clear way to separate (2) and (3) for the experiments in this thesis. Although, there is some previous evidence from Tan et al (1995), that mechanical work and perhaps terminal force cues influence the perception of compliance. In experiments using the Linear Grasper and the same experimental protocol used in this thesis, Tan et al (1995) demonstrated that mechanical work and terminal force cues bias subject responses when discriminating compliance in a roving displacement paradigm. Furthermore, when mechanical work cues were eliminated, compliance JNDs varied from 15–99% and were most parsimoniously explained by terminal force JNDs from 5–7%. Perhaps the results of compliance, viscosity and mass discrimination performance can all be explained in terms of mechanical work or force JNDs. However, experiments to measure mechanical work JNDs under various conditions need to be performed before the fundamental nature of mechanical work versus force can be better debated.

Most investigations of kinesthesia have focused on force and position (Clark and Horch, 1986) and it is unclear how people would estimate mechanical work or perform some form of force averaging over distance. For force, there appear to be two separate mechanisms involved in perception: one arising from tension receptors in the Golgi tendon organs and another resulting from copies of centrally generated motor signals that get fed back to perceptual areas of the brain, called corollary discharges. These corollary discharges appear to be intrinsically connected to subjective impressions of “effort” (McCloskey, 1981). Perhaps, then, subjects attempt to grasp with the same “effort” on every trial (perceived centrally) and measure the resulting tension (perceived kinesthetically through Golgi tendon organs) over finger position (also perceived through appropriate kinesthetic sensory organs). However, it should be noted that the perceptual interaction between force and position is complicated; for example, it has been shown that in the presence of a resisting elastic force, subjects tend to underestimate position (Watson et al, 1984). Thus any discussion about the underlying physiological basis for viscosity and mass perception is speculative at best.

9.2 Future Work

There are several potential avenues for future work, two of which are discussed below.

9.2.1 Complex Object Perception

Because baseline JNDs have been established for the fundamental physical properties of force, compliance, viscosity and mass, experiments can now be initiated to measure the ability to discriminate among complex objects that have various combinations of all or some of these properties. Specifically, experiments could be conducted to measure the ability of subjects to resolve combinations of these properties into their constituent components or simply to measure the ability to resolve differences in the overall mechanical impedance between two complex objects.

These experiments should allow us to test the validity of the active pinch grasp discrimination hypothesis for more complicated objects. First, by recording motor performance during these experiments, we should be able to determine if other subjects apply the same stereotypical force profiles that were recorded for viscosity and mass discrimination. Furthermore, if we postulate that subjects will apply a similar linear force ramp, then for any two objects which consist of different linear combinations of these mechanical properties, we should be able to predict if the resulting spatial force profiles of the objects will be sufficiently different enough to allow the subjects to discriminate on the basis of force. Hopefully, combined with other experiments that measure mechanical work JNDs we may be able to determine if there is an underlying mechanism that can explain active touch discrimination performance for a wide range of object properties.

9.2.2 Multimodal Perception of Object Properties

Another avenue of future work is in the area of multimodal perception of object properties. With a baseline of purely haptic based JNDs for these properties, we can explore the influence of other modalities such as vision and audition on haptic perception of viscosity or mass, for example.

Some preliminary work has already been done in this area regarding on the perception of stiffness in the presence of altered visually presented spatial cues (unpublished work by the author and Srinivasan). Initial results strongly suggest that the phenomena of visual dominance (See Rock and Victor, 1963; and a review by Welch and Warren, 1986) can be used change the perceived stiffness of a “virtual spring”. In these experiments, subjects were given graphically presented visual information on hand location, as they used pushed with their hand on a force-reflecting device with a force profile that was linearly increased with the distance pushed. By altering the relationship between the actual distance pushed and the visually displayed pushing distance, we could manipulate the relative level of perceived stiffness of the spring. One explanation, consistent with the pinch grasp discrimination hypothesis, is that by altering the spatial force mapping with visual information we were able to modify the perceived stiffness of the spring.

These are only preliminary results, but point to an interesting and potentially very relevant area of research for virtual environments. Similar research with sound and or visual cues also needs to be investigated.

9.3 Conclusion

In this thesis, the manual resolution of viscosity and mass was explored and the role of sensorimotor performance in affecting the discrimination of these properties was investigated. The results indicated that even though the magnitude of the forces, velocities, and accelerations were different among subjects and across experimental conditions, certain fundamental motor performance characteristics could be observed. An analysis of these motor characteristics lead to the postulation of a simple sensorimotor strategy to explain motor performance for both viscosity and mass discrimination experiments. This strategy is not only consistent with the observed motor data but also successfully predicts the measured discrimination for viscosity and mass.

Appendix A

The following is taken directly from Durlach (1968) and is reprinted with permission.

The One Interval Two Alternative Forced Choice (1I-2AFC) Paradigm

Basic Structure and Procedure:

The one-interval, two alternative forced choice experiment is designed such that:

- 1) There are two admissible stimuli, S_1 and S_2 .
- 2) There are two admissible responses, R_1 and R_2 .
- 3) On each trial, the experimenter presents S_1 or S_2 randomly with *a priori* probabilities $P(S_1)$ and $P(S_2) = 1 - P(S_1)$.
- 4) The subject is instructed to respond R_1 when stimuli S_1 is presented and R_2 when the stimuli S_2 is presented.
- 5) The experimenter “pays off” the subject for responding R_j to S_i with a positive reward when $j = i$ and a negative reward $j \neq i$.

For all the discrimination experiments carried out in this thesis, S_1 and S_2 are identified with specific non-zero stimuli, for example, two distinct viscosities. The paradigm is called “one-interval” because only one of the two admissible stimuli is given on a single trial. The term “two alternative forced choice” refers to the fact there are only two allowable responses and that the subject is forced to choose one of them. In addition, for all the discrimination experiments in this thesis, the subject is provided with correct response feedback upon selecting a response.

The results of a particular discrimination experiment can be organized by a 2x2 matrix whose entries are the relative frequencies of responding R_i to S_j :

$$f_{ij} = \frac{N(R_i|S_j)}{N(R_1|S_j) + N(R_2|S_j)}$$

where $N(R_i|S_j)$ is the number of times the subject responded R_i to S_j , and $N(R_1|S_j) + N(R_2|S_j)$ is the number of times S_j was presented. To the extent that $f(R_1|S_1)$ and $f(R_1|S_2)$ have different values measures the extent to which the subject has demonstrated a sensitivity to differences in S_1 and S_2 . The extent to which both $f(R_1|S_1)$ and $f(R_2|S_1)$ are close to unity measures the degree to which the subject has exhibited a bias to respond R_1 rather than R_2 .

Decision Model for the 1I-2AFC Paradigm

The axioms of the 1I-2AFC decision model are:

- 1) There exists a real random variable X , (the “decision space”) with the property that each stimulus presentation determines a value of X . The decision space is assumed to be unidimensionable.
- 2) There exists a fixed cut-off value, C , (the “criterion”) on the X axis.
- 3) The subject responds R_1 if and only if, $X < C$ and R_2 if and only if, $X \geq C$.

The statistics of X are independent of all aspects of the experiment except S_1 and S_2 , and are described completely by the conditional probability density functions $p_x(X_0|S_1)$ and $p_x(X_0|S_2)$. In particular the statistics are independent of the a priori probabilities and payoffs, and the trials of the experiment are statistically independent.

The model is illustrated in Figure B-1. The conditional response probabilities $P(R_i | S_j)$ are given by:

$$\begin{aligned} P(R_1|S_1) &= \int_{-\infty}^C p_x(X_0|S_1)dX_0 & P(R_2|S_1) &= \int_C^{+\infty} p_x(X_0|S_1)dX_0 \\ P(R_1|S_2) &= \int_{-\infty}^C p_x(X_0|S_2)dX_0 & P(R_2|S_2) &= \int_C^{+\infty} p_x(X_0|S_2)dX_0 \end{aligned}$$

and are related by:

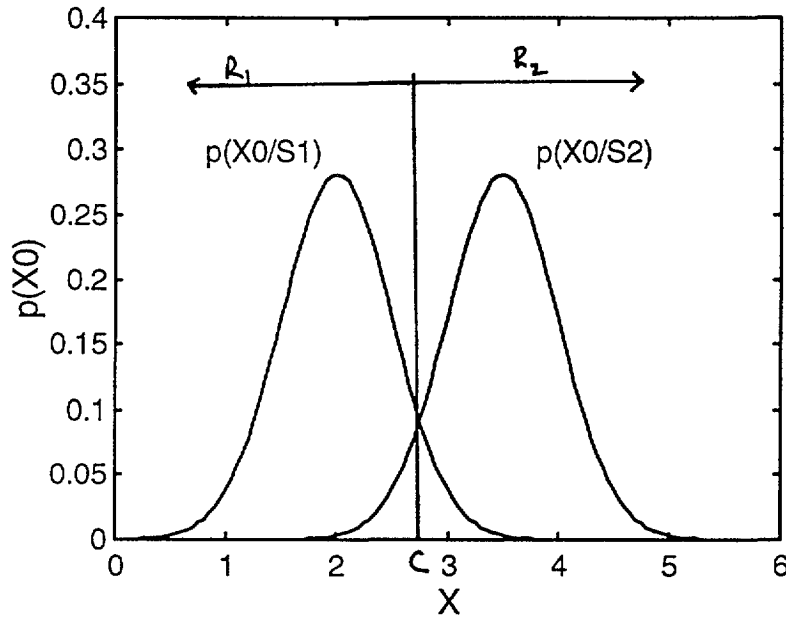

Figure A.1: Decision Model for II-2AFC Paradigm

$$P(R_1 | S_j) + P(R_2 | S_j) = 1 \text{ for } j = 1, 2$$

According to the model, the sensitivity of the system is determined by the extent to which the densities are nonoverlapping, and the bias of the system by the criterion C . Generally, the value of C is presumed to depend on the payoffs and the a priori probabilities $P(S_j)$. For example, if the subject is informed that $P(S_1) \gg P(S_2)$, the subject is likely to be biased towards responding R_1 rather than R_2 and therefore will choose a relatively large value of C . It is also important to note that the decision model implies that a change in a priori probabilities or payoffs will not affect the underlying conditional probability density functions.

The model is further specified by assuming the conditional probability densities are Gaussian and of equal variance:

$$p_X(X_0 | S_j) = \frac{1}{\sqrt{2\pi\sigma}} e^{-\frac{(X_0 - M_j)^2}{2\sigma^2}}$$

The assumption that the densities are Gaussian is reasonable if X is assumed to be the sum of a large number of similar, independent, random variable and assume that some form of the Central Limit Theorem is applicable. This assumption combined with the assumption of equal variances makes the model very simple mathematically. From this a *sensitivity index*, d' , can be defined as the normalized difference between the means of the two densities (M_1 and M_2):

$$d' = (M_2 - M_1) / \sigma$$

A *bias*, β , can be defined as the normalized deviation of the response criterion, C , from the midpoint between the two means:

$$\beta = [C - (M_2 + M_1) / 2] / \sigma$$

The normalization has been chosen so that $\beta = 0$ when the subject exhibits unbiased behavior, $\beta = 0.5d'$ when $C = M_2$ and $\beta = -0.5d'$ when $C = M_1$.

Generally speaking the values of d' are found to be roughly proportional to the difference between S_1 and S_2 , typically denoted by the incremental difference ($\Delta S/S_1$). Given this proportionality, performance can be summarized by the slope $\delta = d' / (\Delta S/S_1)$ averaged over the different values of $\Delta S/S_1$ tested for the same S_1 . The **JND** is defined for the performance threshold of $d' = 1$. The Weber fraction denoted by **JND%** is computed by from the average $\bar{\delta}$:

$$JND\% = \frac{1}{\bar{\delta}} * 100\%$$

Appendix B

Viscosity Discrimination Motor Performance Data:

Presented in Appendix B is the motor performance data recorded during the viscosity discrimination experiments with different references. For each subject, force and velocity data are plotted versus time and squeezing distance for all references. Because there was a considerable amount of data recorded during these experiments, for each subject, only data from one experimental run is shown for each stimulus pair. Data from a total of 2,304 trials are presented.

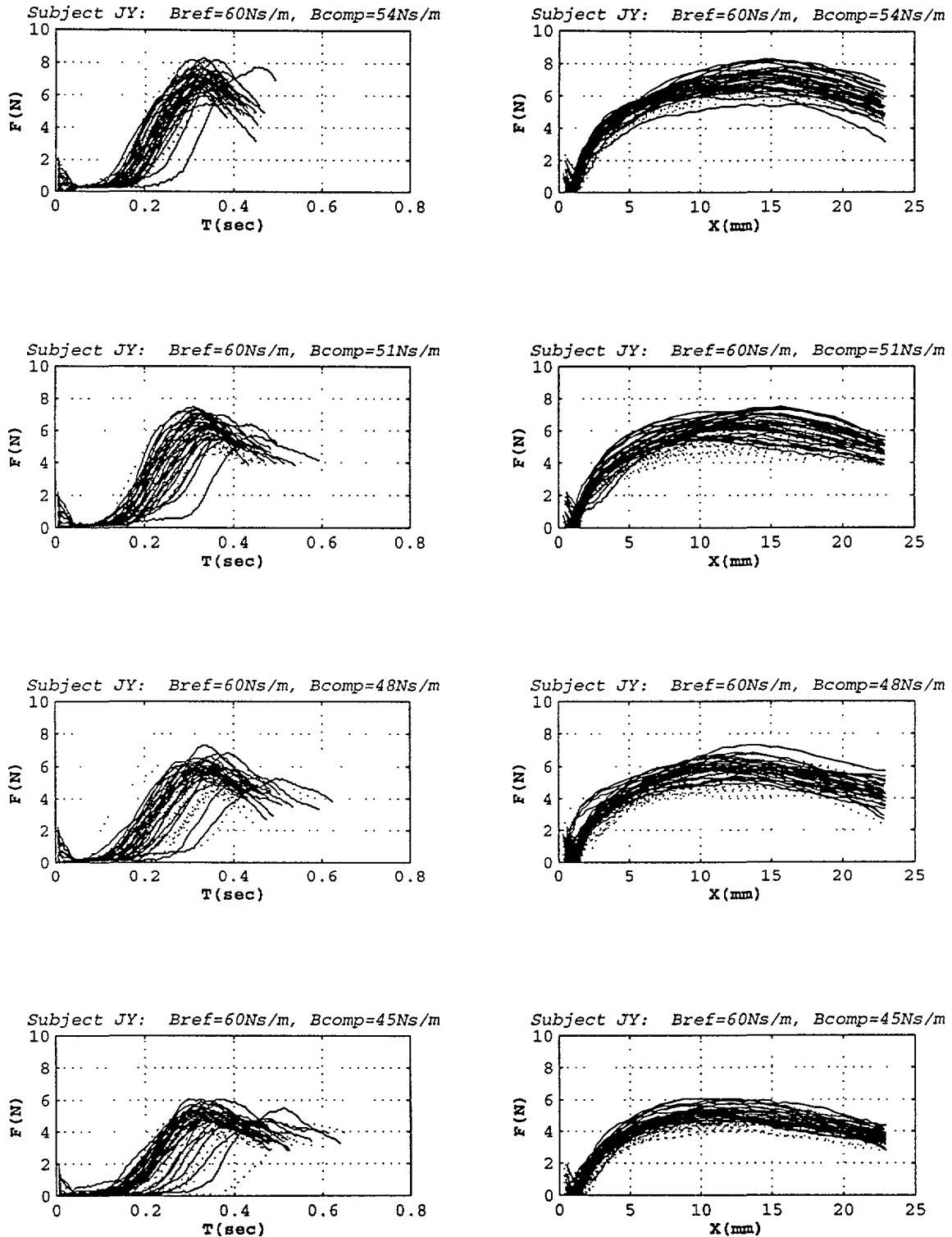

Figure B.1: Force Data for Subject JY with Reference Viscosity = 60Ns/m. Force data plotted versus time and squeezing distance for all stimulus pairs. Solid lines are for trials where the reference was presented and dotted lines represent trials where the comparison was presented.

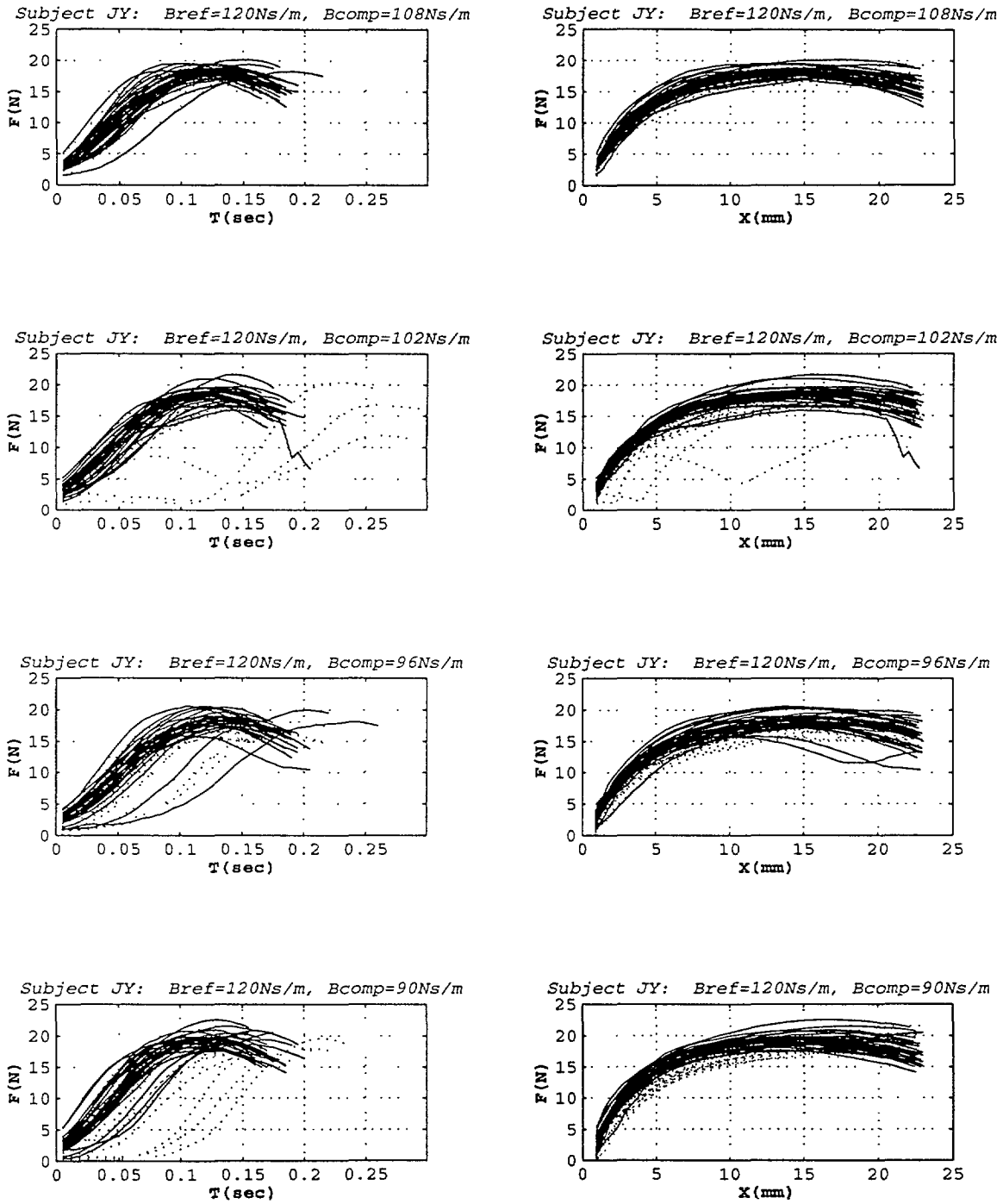

Figure B.2: Force Data for Subject JY with Reference Viscosity =120Ns/m. Force data plotted versus time and squeezing distance for all stimulus pairs. Solid lines are for trials where the reference was presented and dotted lines represent trials where the comparison was presented.

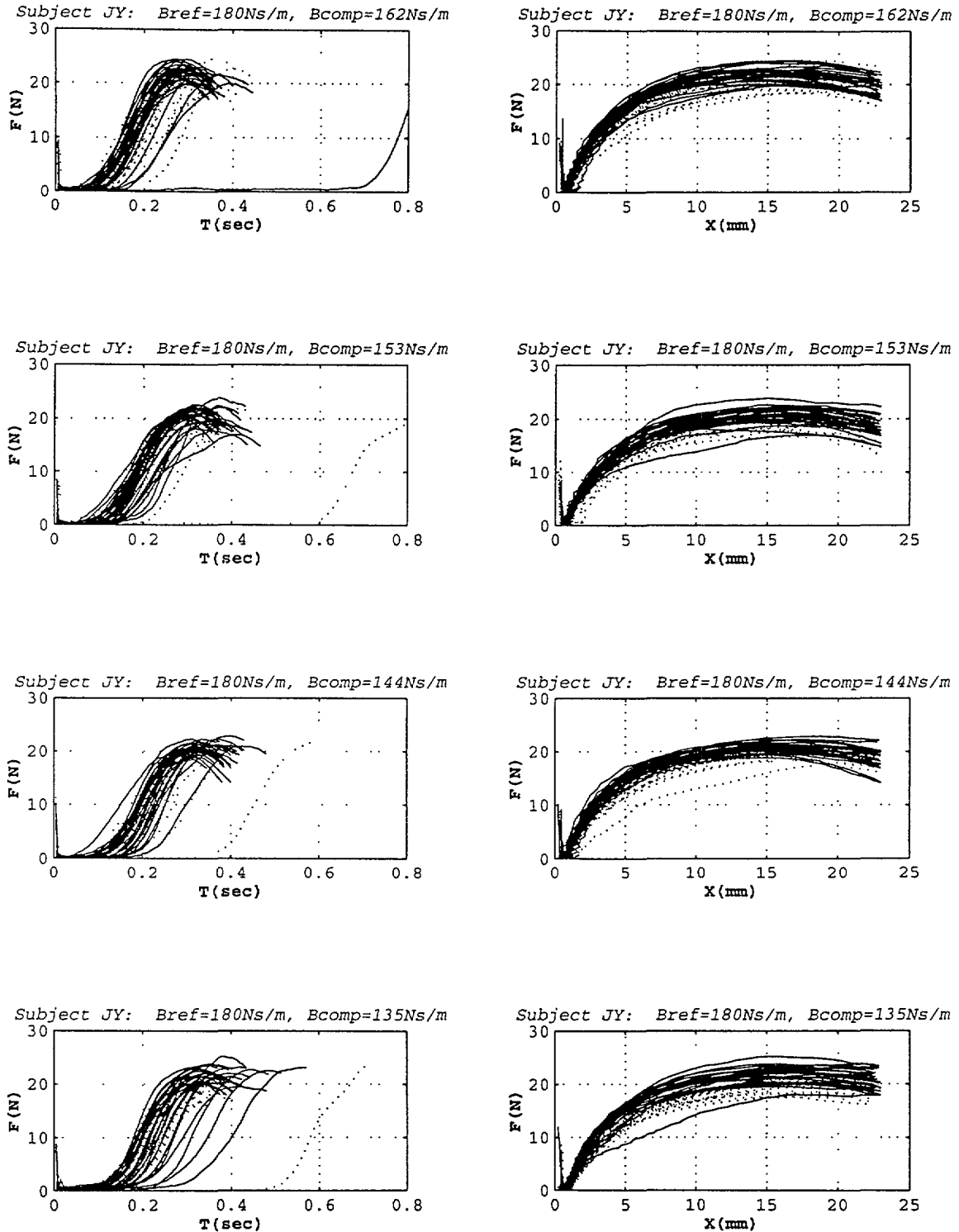

Figure B.3: Force Data for Subject JY with Reference Viscosity =180Ns/m. Force data plotted versus time and squeezing distance for all stimulus pairs. Solid lines are for trials where the reference was presented and dotted lines represent trials where the comparison was presented.

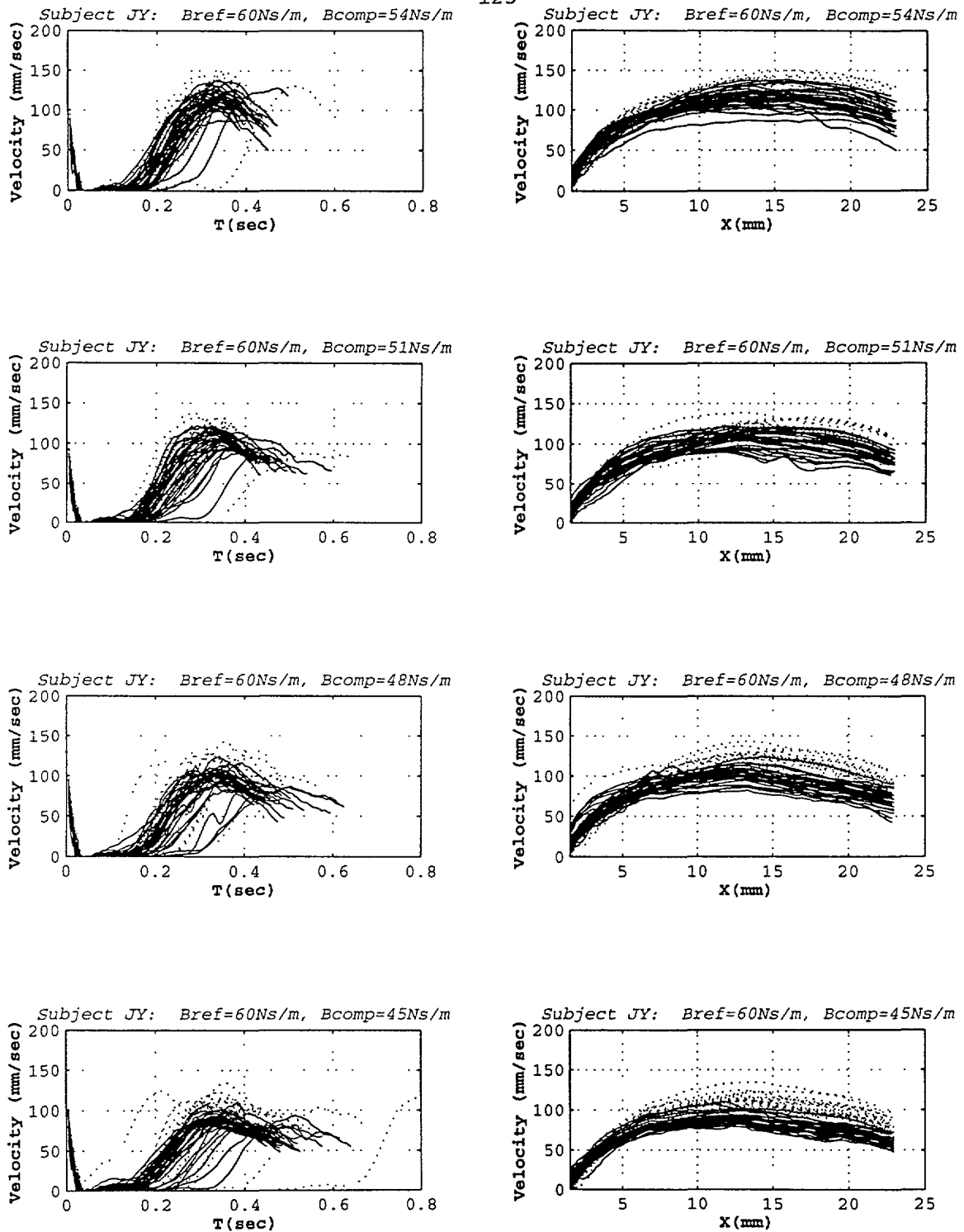

Figure B.4 Velocity Data for Subject JY with Reference Viscosity = 60Ns/m. Velocity data plotted versus time and squeezing distance for all stimulus pairs. Solid lines are for trials where the reference was presented and dotted lines represent trials where the comparison was presented.

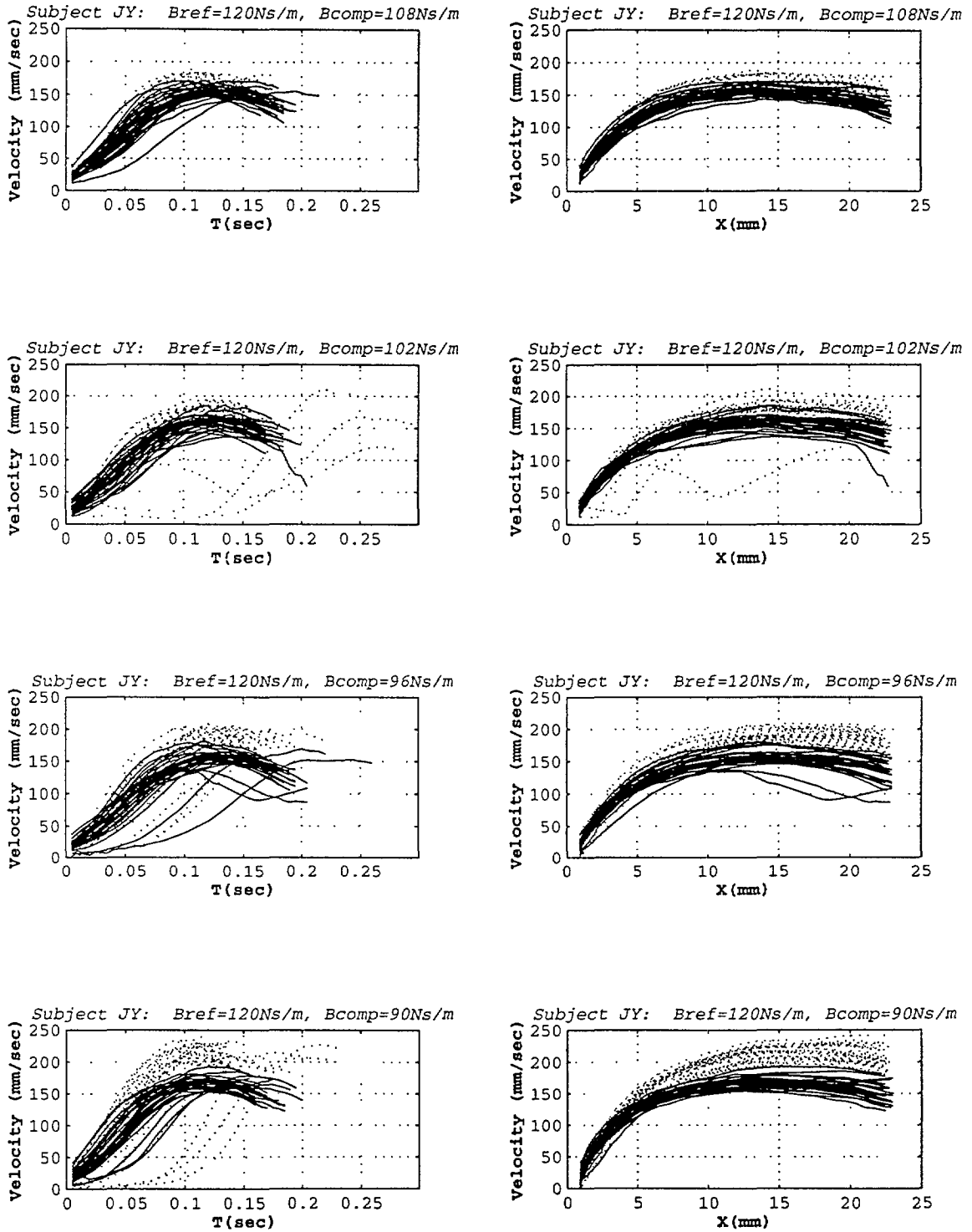

Figure B.5: Velocity Data for Subject JY with Reference Viscosity =120Ns/m. Velocity data plotted versus time and squeezing distance for all stimulus pairs. Solid lines are for trials where the reference was presented and dotted lines represent trials where the comparison was presented.

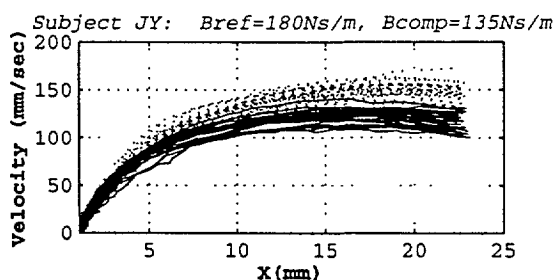
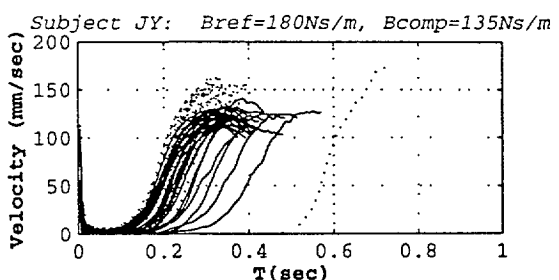
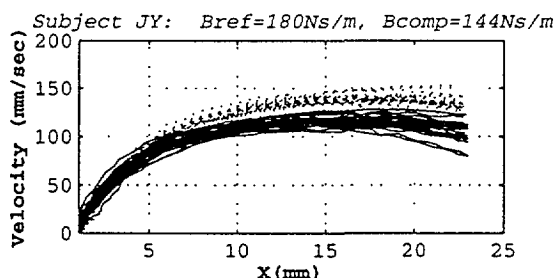
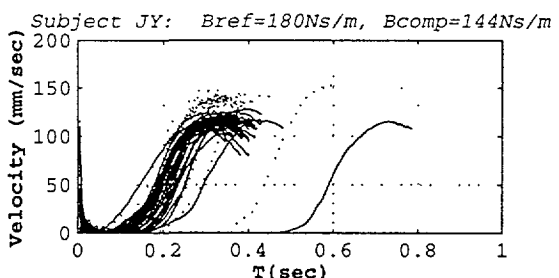
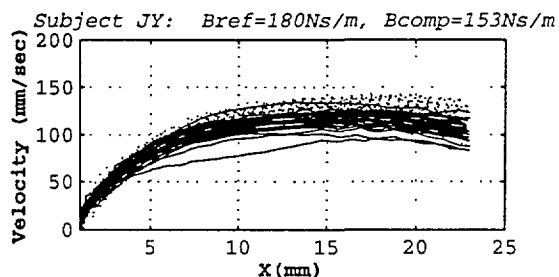
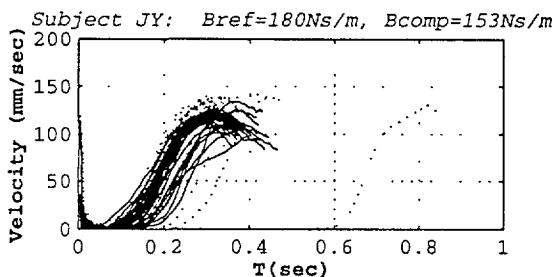
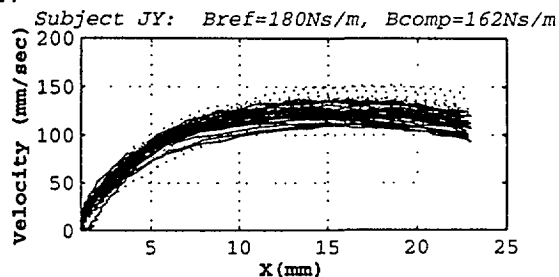
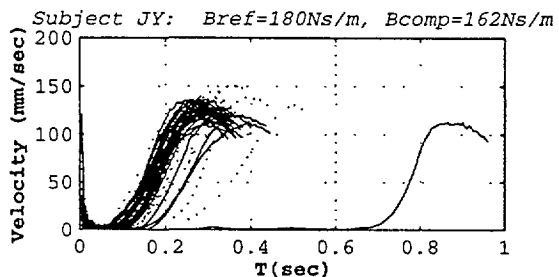

Figure B.6: Velocity Data for Subject JY with Reference Viscosity =180Ns/m. Velocity data plotted versus time and squeezing distance for all stimulus pairs. Solid lines are for trials where the reference was presented and dotted lines represent trials where the comparison was presented.

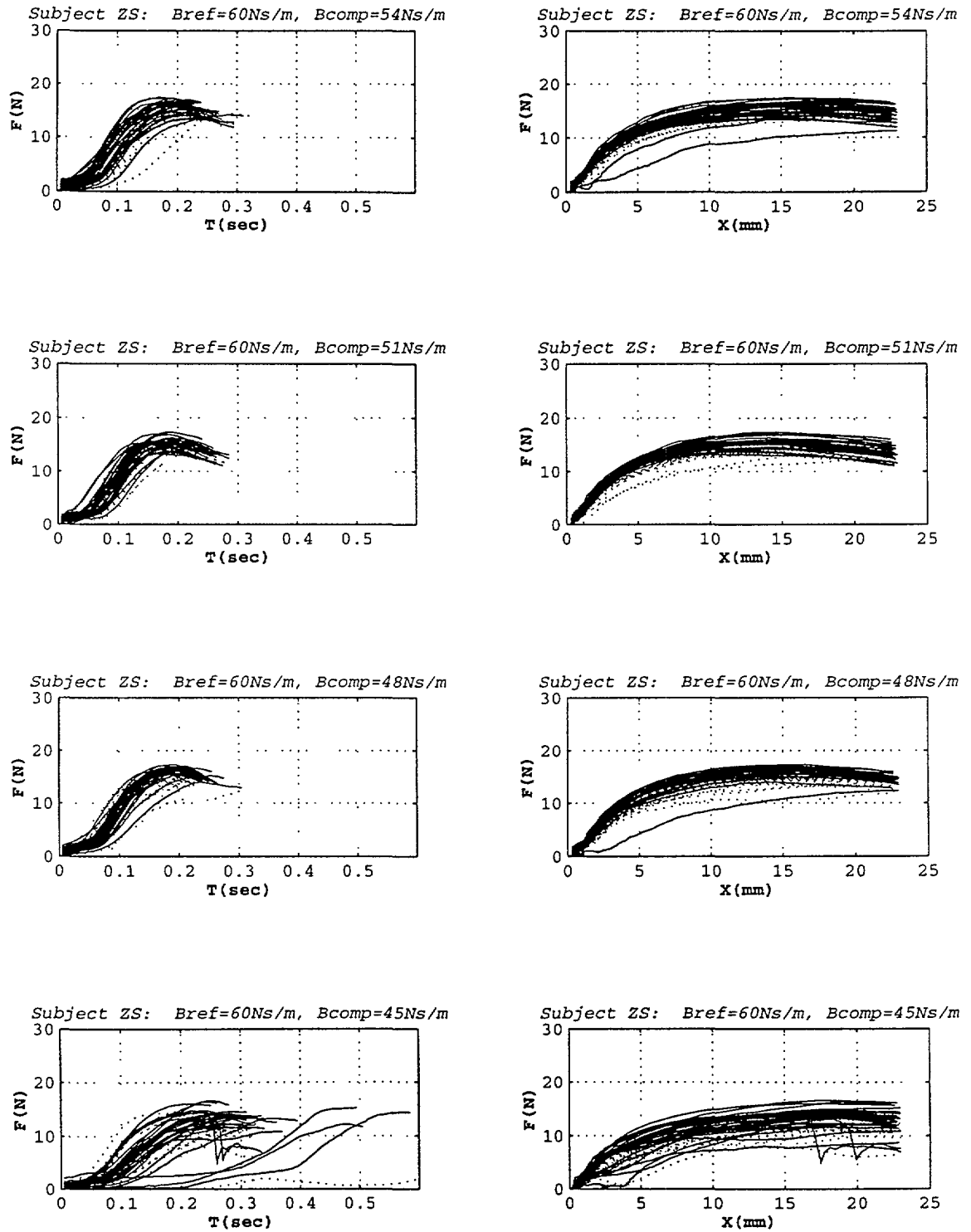

Figure B.7: ForceData for Subject ZS with Reference Viscosity = 60Ns/m. Force data plotted versus time and squeezing distance for all stimulus pairs. Solid lines are for trials where the reference was presented and dotted lines represent trials where the comparison was presented.

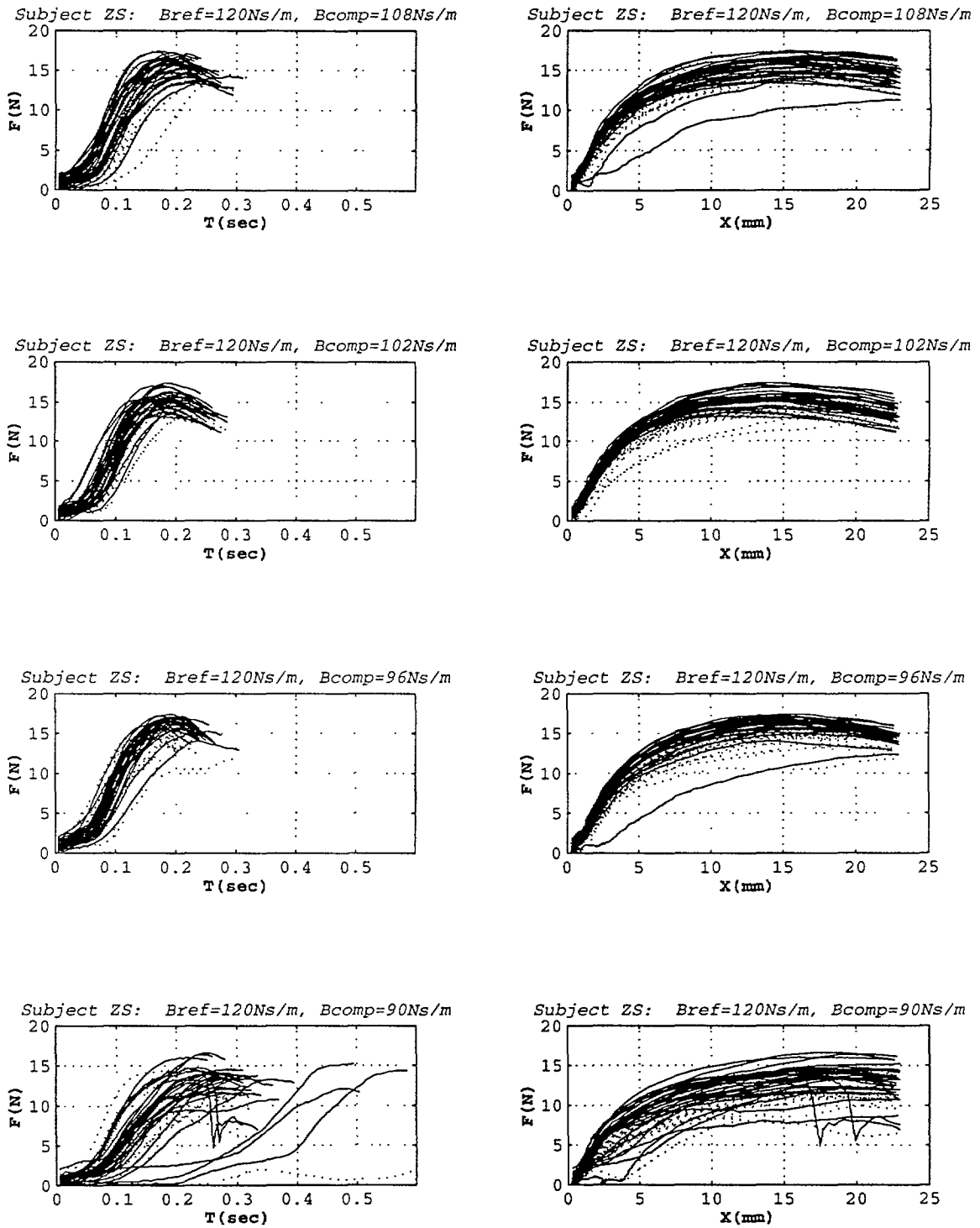

Figure B.8: ForceData for Subject ZS with Reference Viscosity = 120Ns/m. Force data plotted versus time and squeezing distance for all stimulus pairs. Solid lines are for trials where the reference was presented and dotted lines represent trials where the comparison was presented.

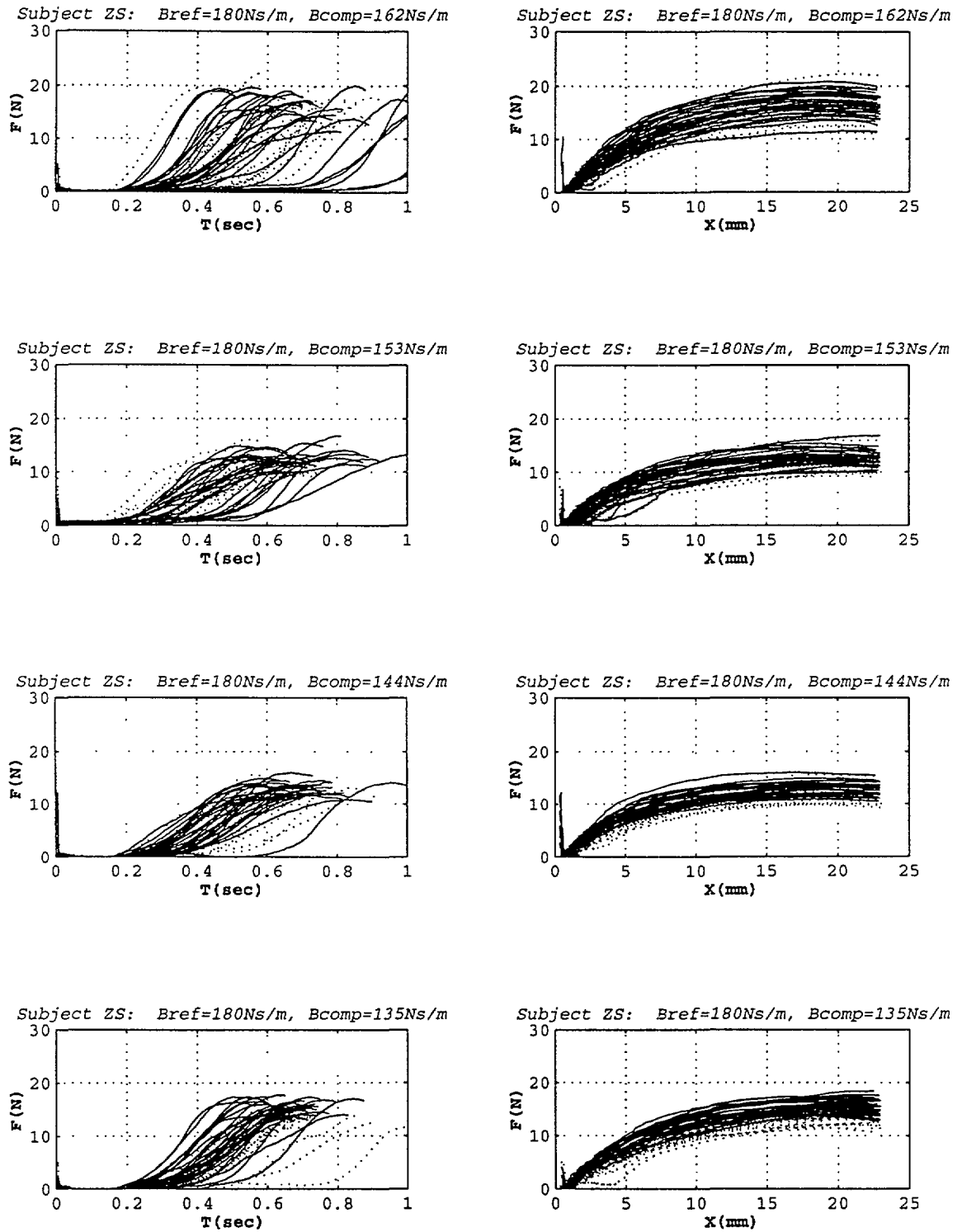

Figure B.9: ForceData for Subject ZS with Reference Viscosity = 180Ns/m. Force data plotted versus time and squeezing distance for all stimulus pairs. Solid lines are for trials where the reference was presented and dotted lines represent trials where the comparison was presented.

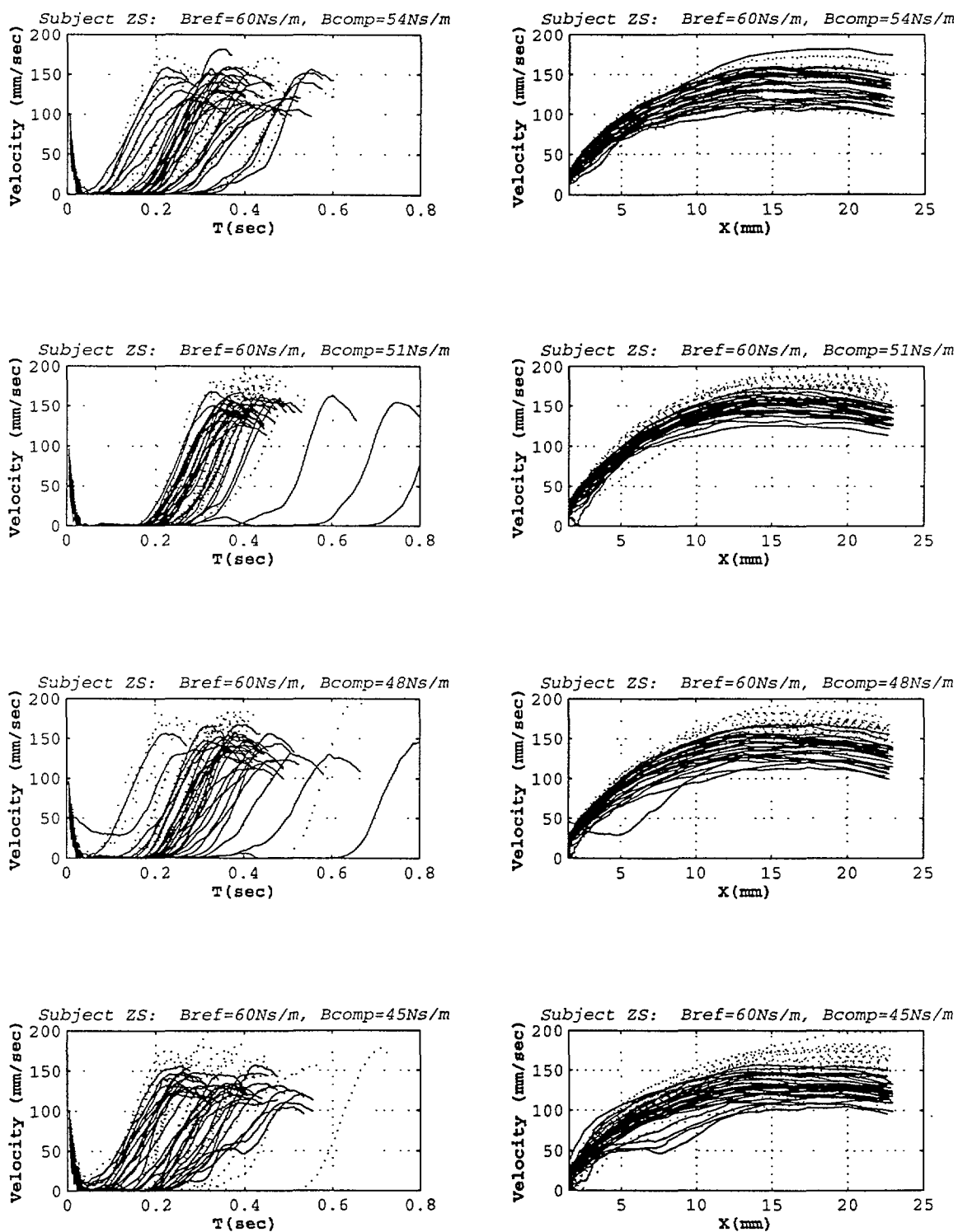

Figure B.10: Velocity Data for Subject ZS with Reference Viscosity = 60Ns/m. Velocity data plotted versus time and squeezing distance for all stimulus pairs. Solid lines are for trials where the reference was presented and dotted lines represent trials where the comparison was presented.

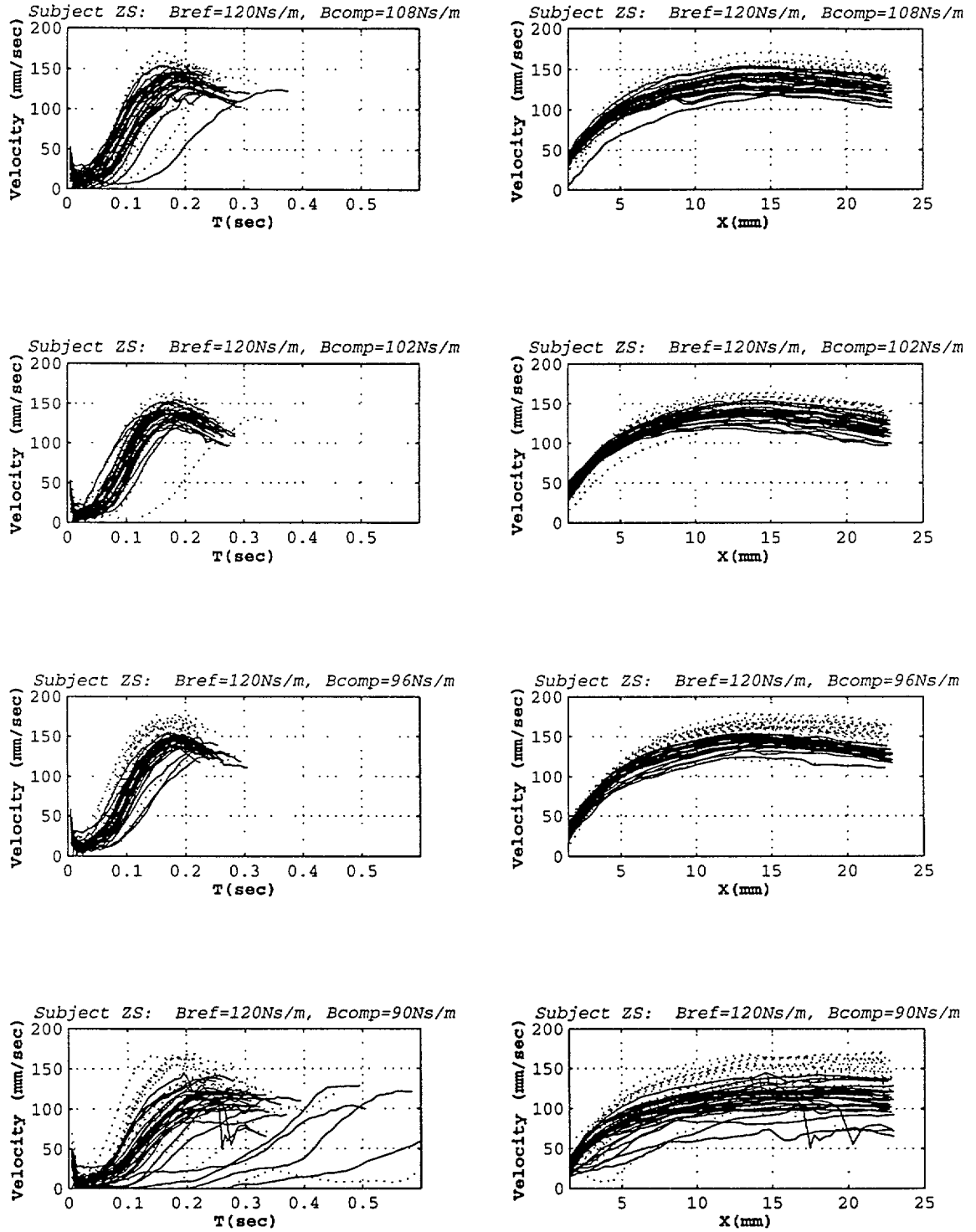

Figure B.11: Velocity Data for Subject ZS with Reference Viscosity = 120Ns/m. Velocity data plotted versus time and squeezing distance for all stimulus pairs. Solid lines are for trials where the reference was presented and dotted lines represent trials where the comparison was presented.

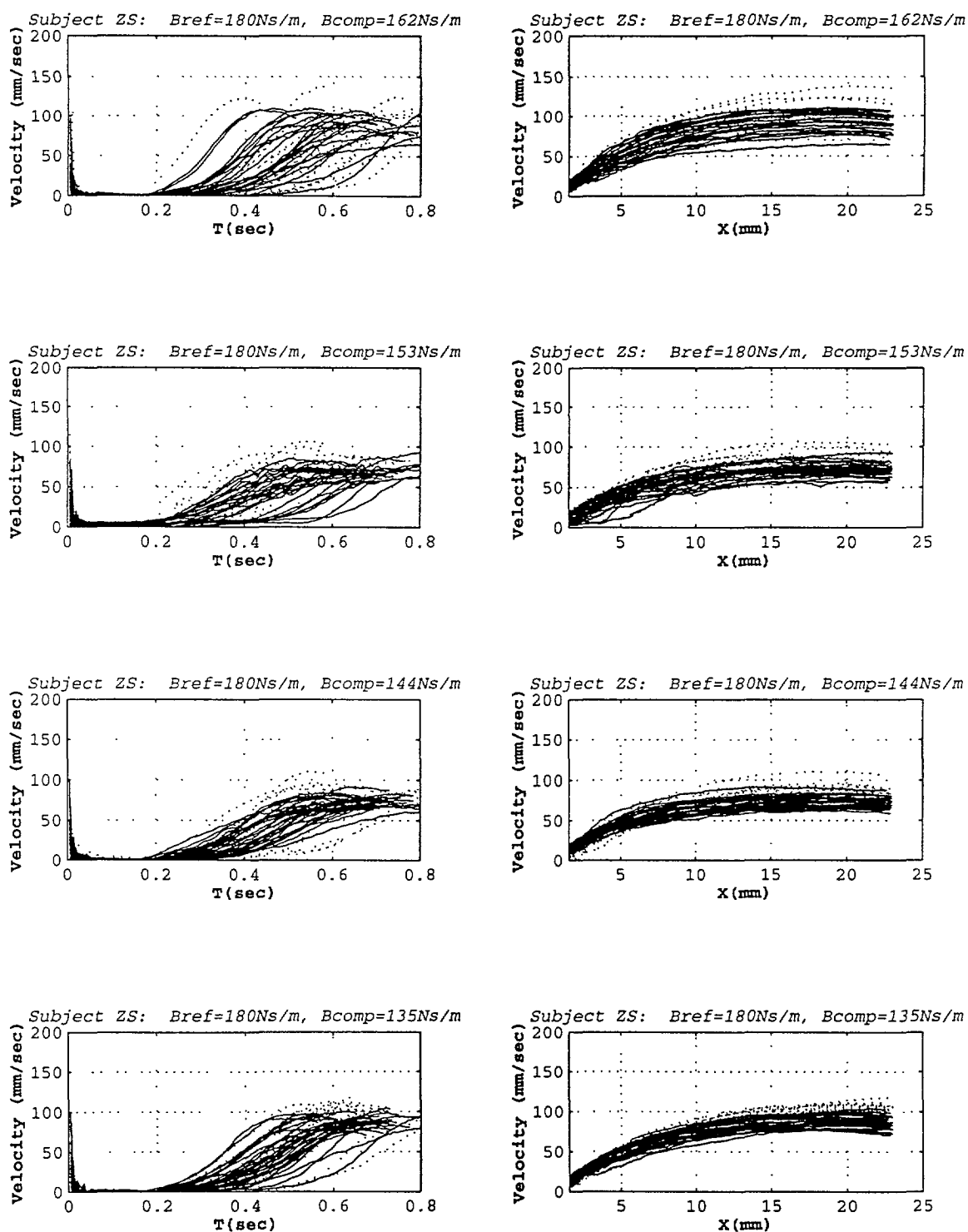

Figure B.12: Velocity Data for Subject ZS with Reference Viscosity = 180Ns/m. Velocity data plotted versus time and squeezing distance for all stimulus pairs. Solid lines are for trials where the reference was presented and dotted lines represent trials where the comparison was presented.

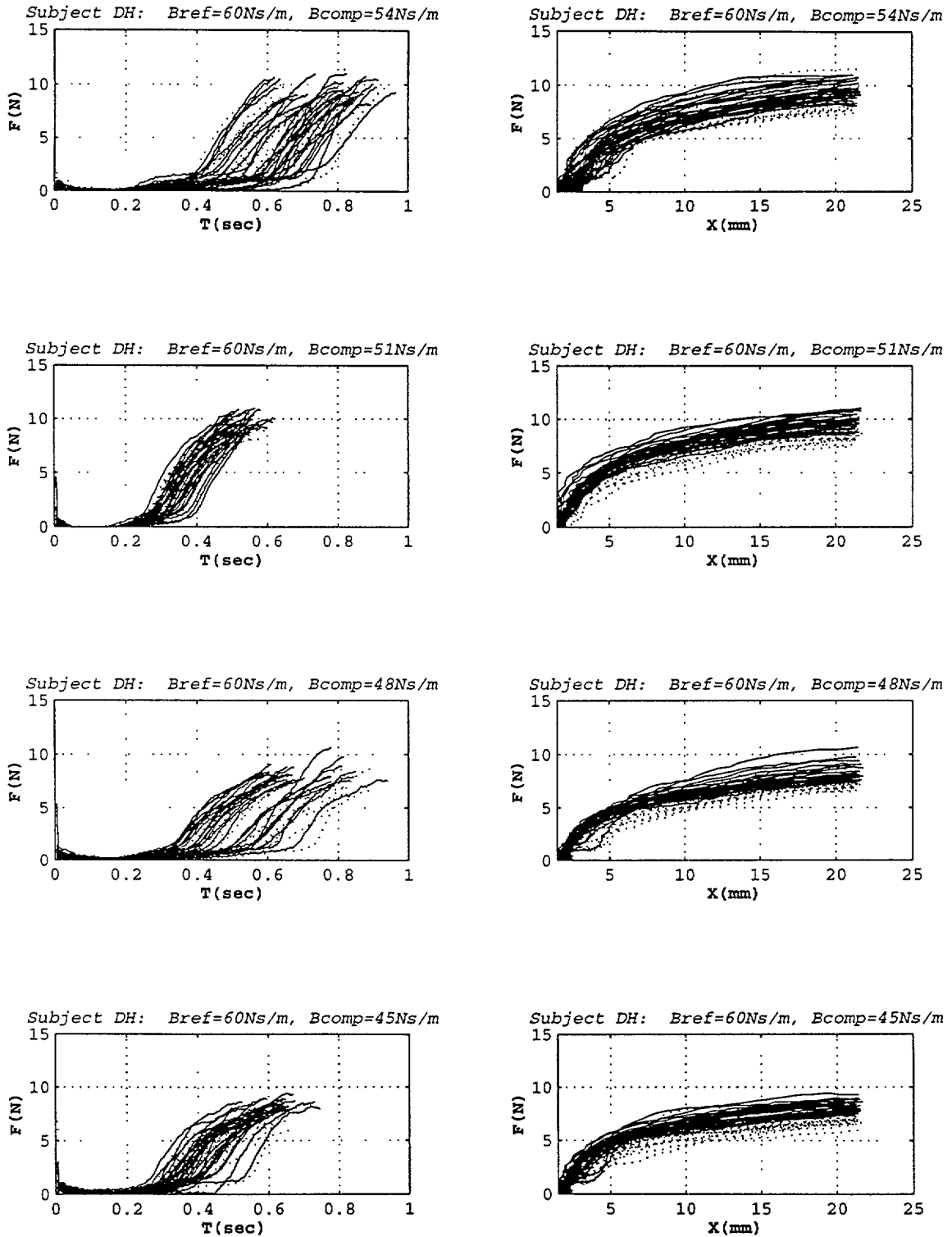

Figure B.13: Force Data for Subject DH with Reference Viscosity = 60Ns/m. Force data plotted versus time and squeezing distance for all stimulus pairs. Solid lines are for trials where the reference was presented and dotted lines represent trials where the comparison was presented.

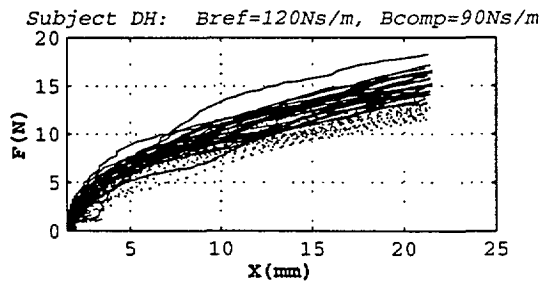
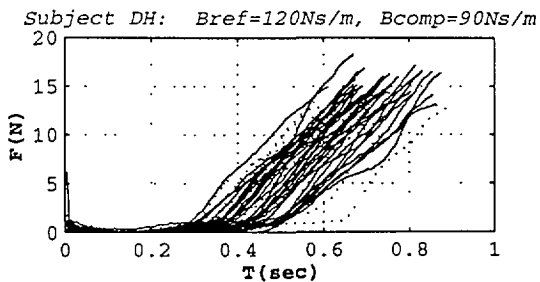
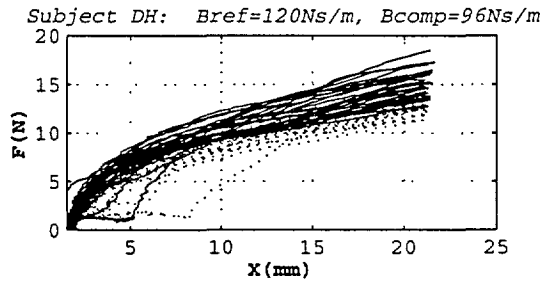
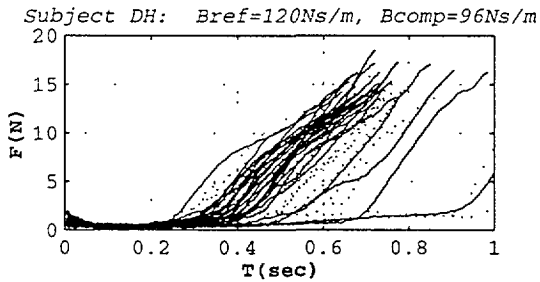
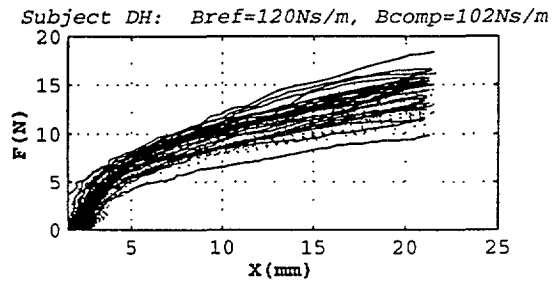
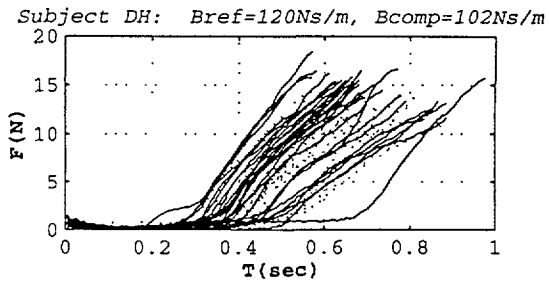
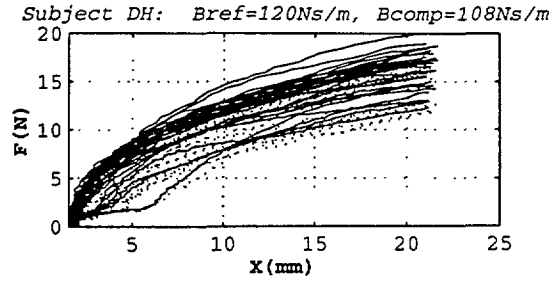
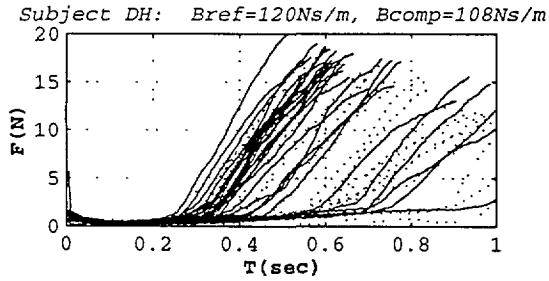

Figure B.14: Force Data for Subject DH with Reference Viscosity = 120Ns/m. Force data plotted versus time and squeezing distance for all stimulus pairs. Solid lines are for trials where the reference was presented and dotted lines represent trials where the comparison was presented.

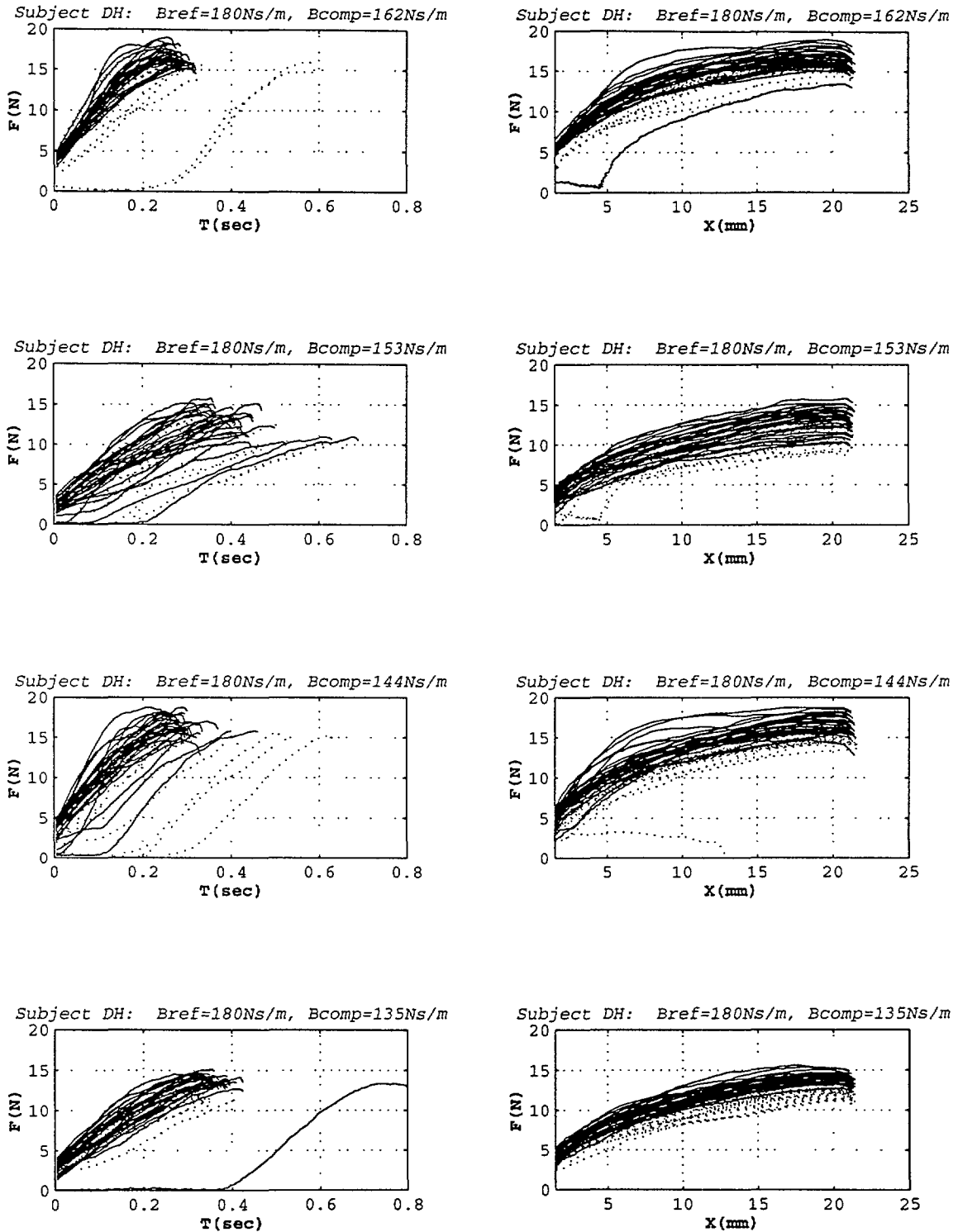

Figure B.15: Force Data for Subject DH with Reference Viscosity =180Ns/m. Force data plotted versus time and squeezing distance for all stimulus pairs. Solid lines are for trials where the reference was presented and dotted lines represent trials where the comparison was presented.

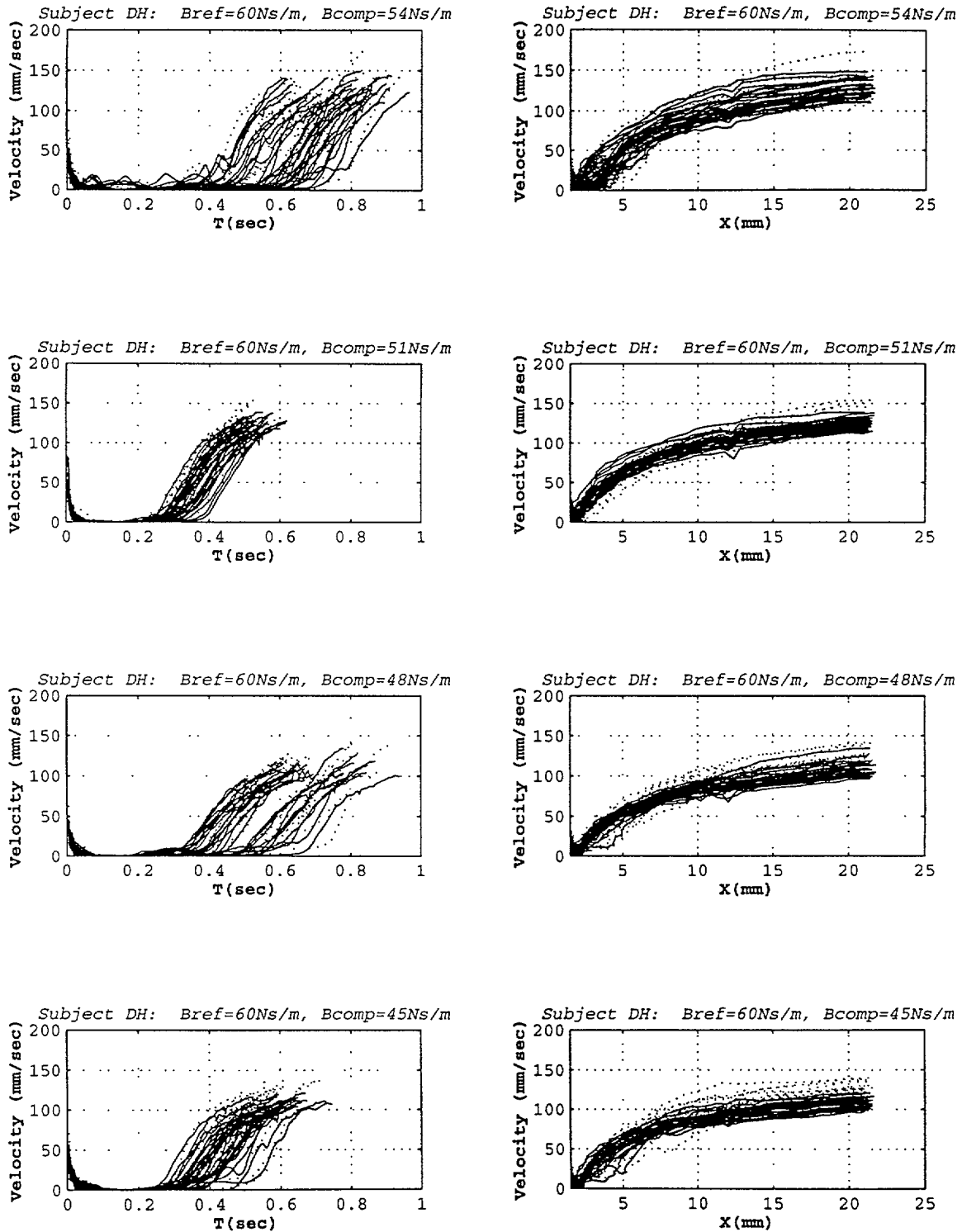

Figure B.16 Velocity Data for Subject DH with Reference Viscosity = 60 Ns/m. Velocity data plotted versus time and squeezing distance for all stimulus pairs. Solid lines are for trials where the reference was presented and dotted lines represent trials where the comparison was presented.

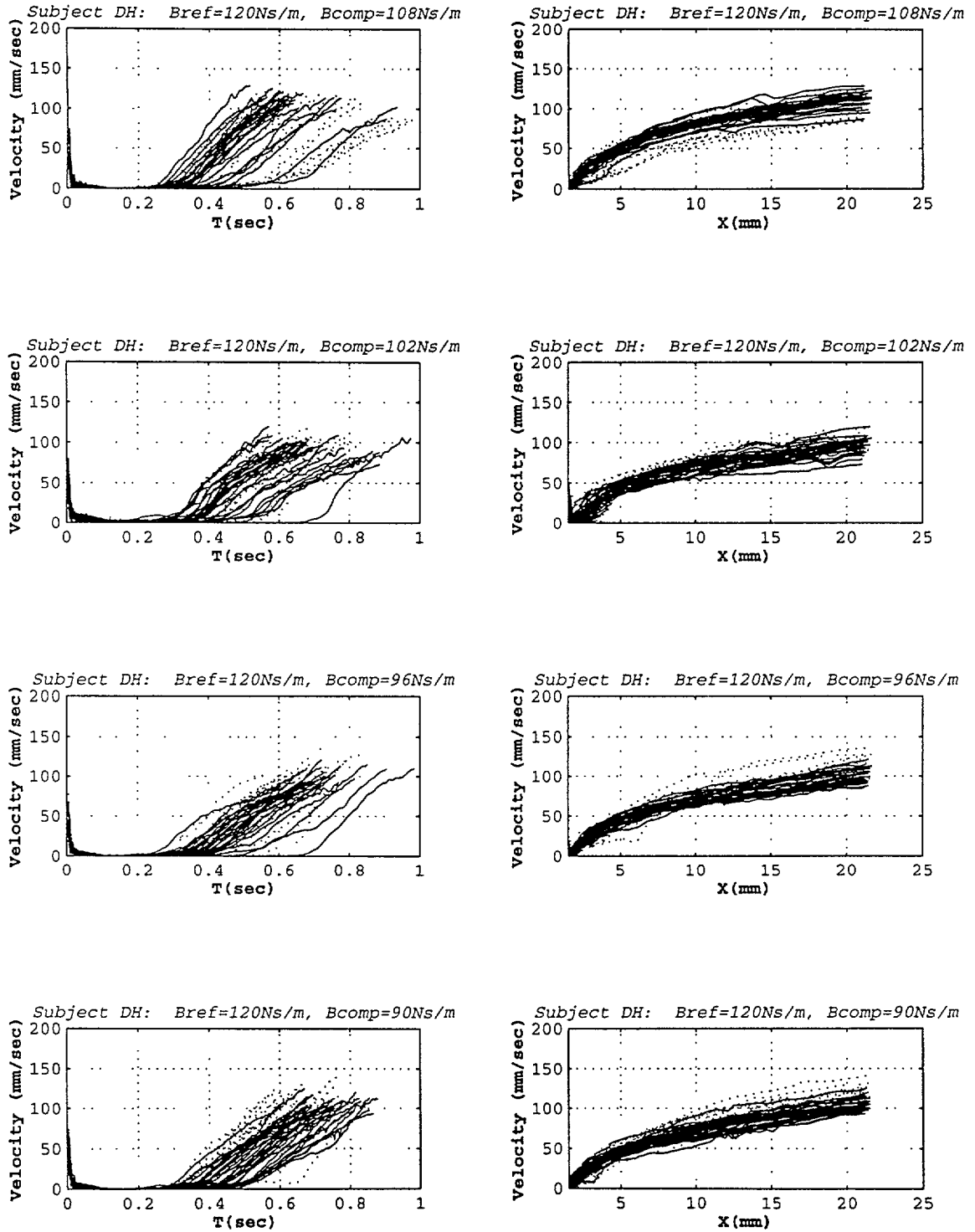

Figure B.17: Velocity Data for Subject DH with Reference Viscosity =120Ns/m. Velocity data plotted versus time and squeezing distance for all stimulus pairs. Solid lines are for trials where the reference was presented and dotted lines represent trials where the comparison was presented.

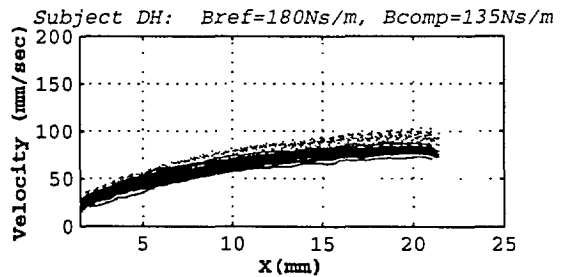
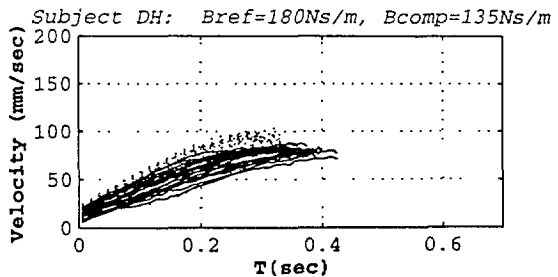
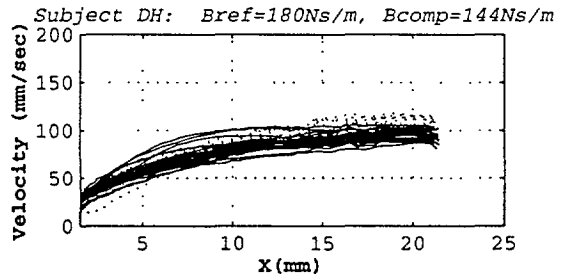
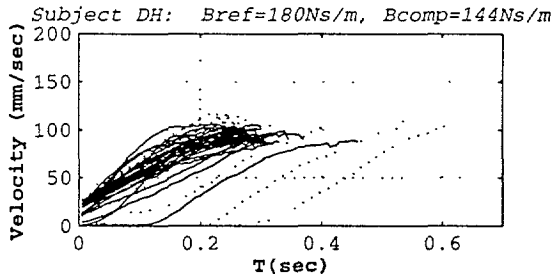
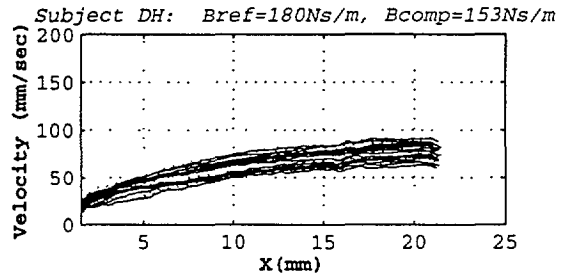
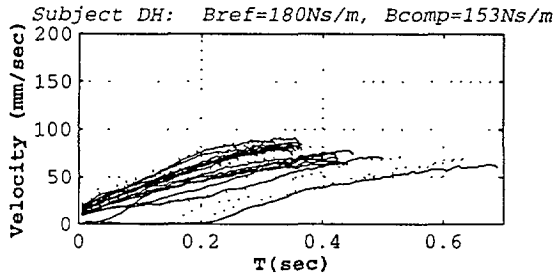
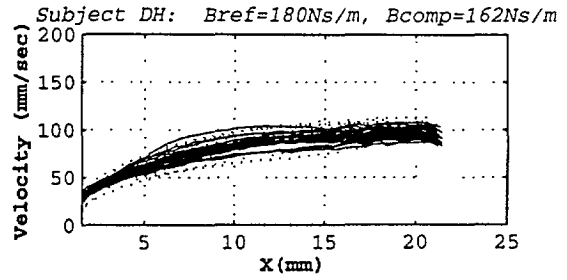
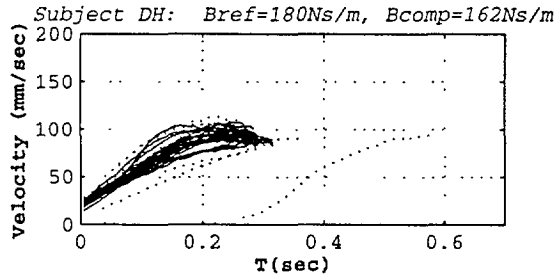

Figure B.18: Velocity Data for Subject DH with Reference Viscosity =180Ns/m. Velocity data plotted versus time and squeezing distance for all stimulus pairs. Solid lines are for trials where the reference was presented and dotted lines represent trials where the comparison was presented.

Appendix C

Mass Discrimination Motor Performance Data:

Presented in Appendix C is the motor performance data recorded during the mass discrimination experiments with different references. For each subject, force and acceleration data are plotted versus time and squeezing distance for all references. Because there was a considerable amount of data recorded during these experiments, for each subject, only data from one experimental run is shown for each stimulus pair. Data from a total of 2,304 trials are presented.

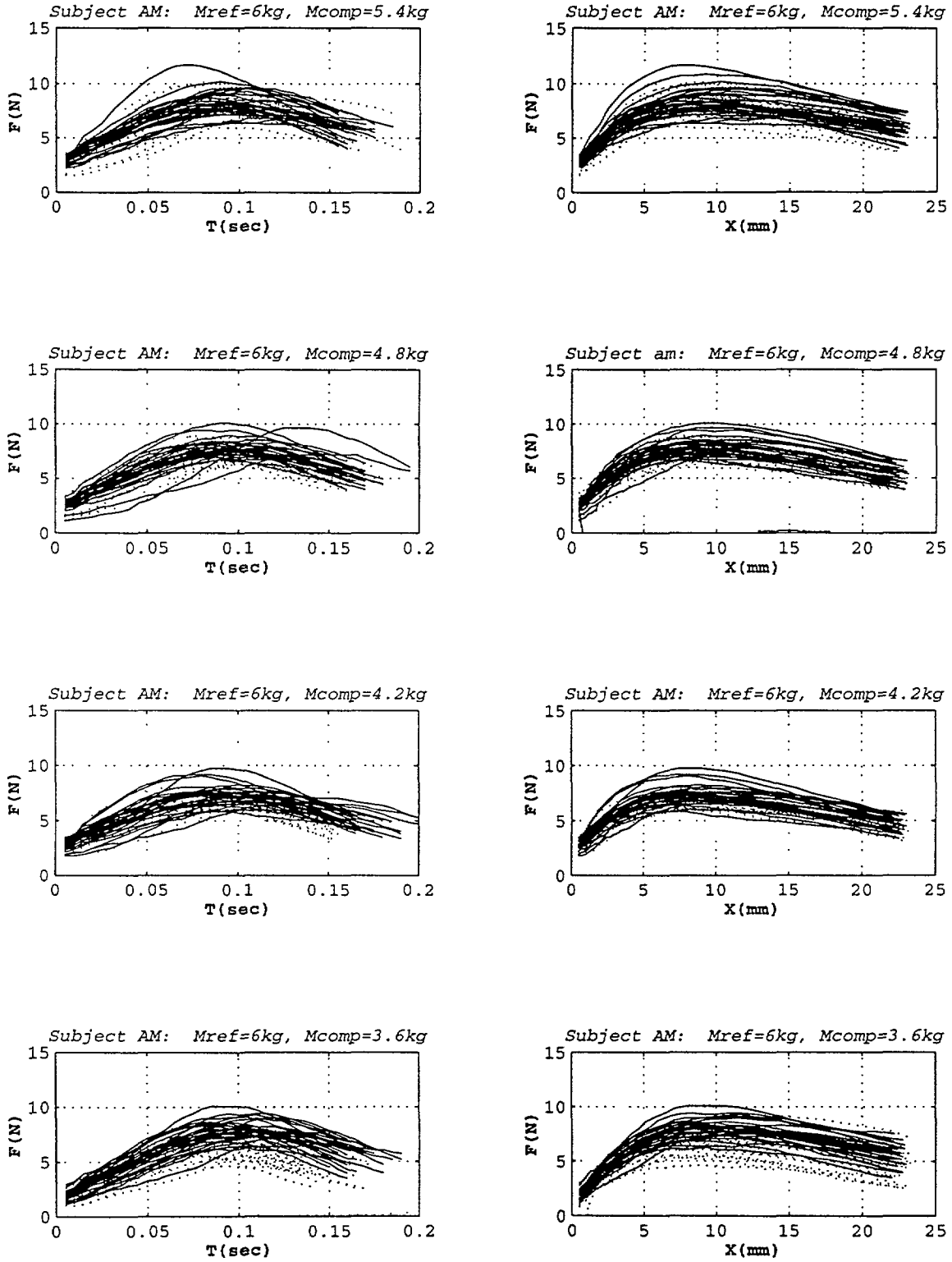

Figure C.1: Force Data for Subject AM with Reference Mass = 6kg. Force data plotted versus time and squeezing distance for all stimulus pairs. Solid lines are for trials where the reference was presented and dotted lines represent trials where the comparison was presented.

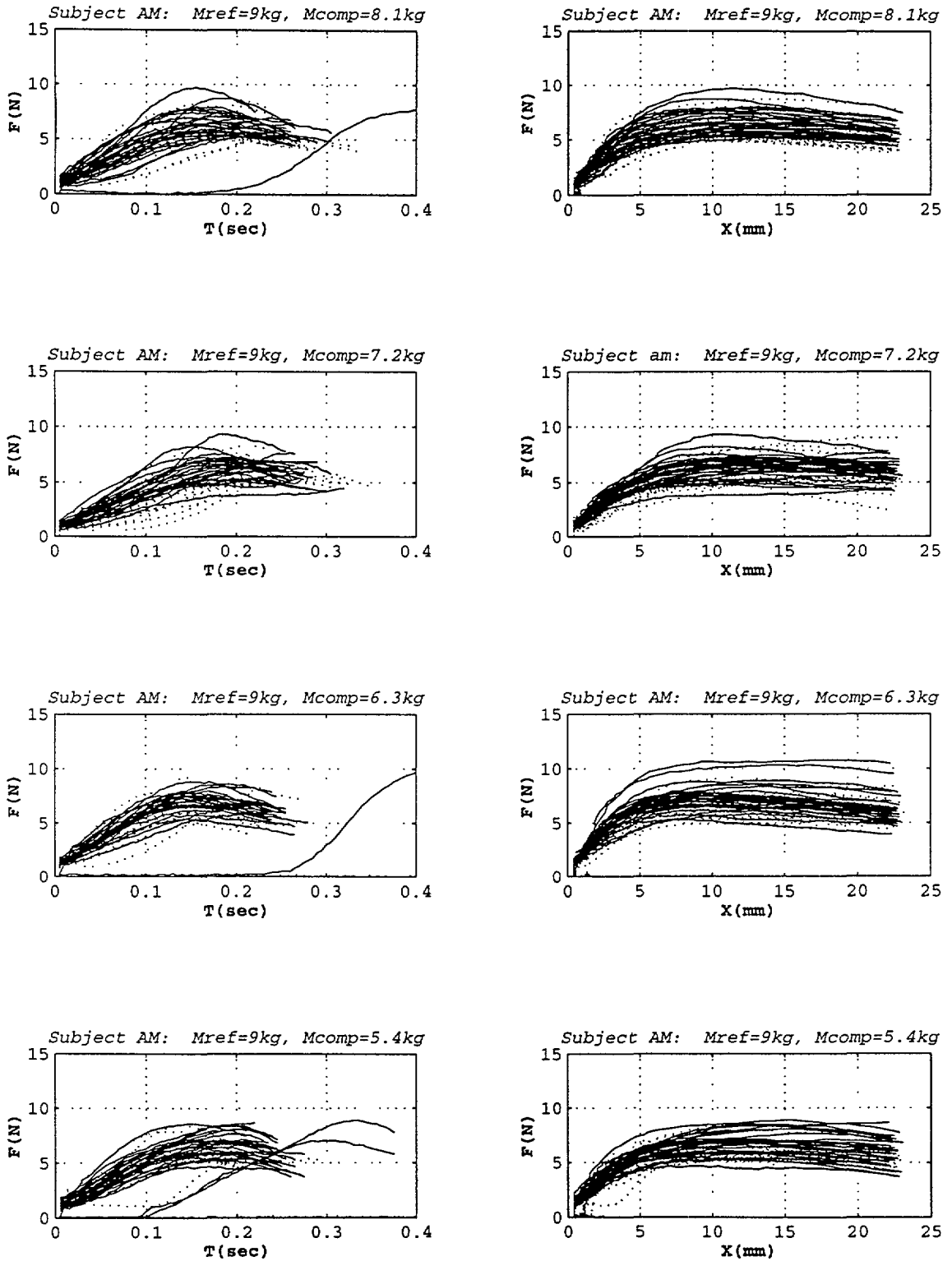

Figure C.2: Force Data for Subject AM with Reference Mass =9kg. Force data plotted versus time and squeezing distance for all stimulus pairs. Solid lines are for trials where the reference was presented and dotted lines represent trials where the comparison was presented.

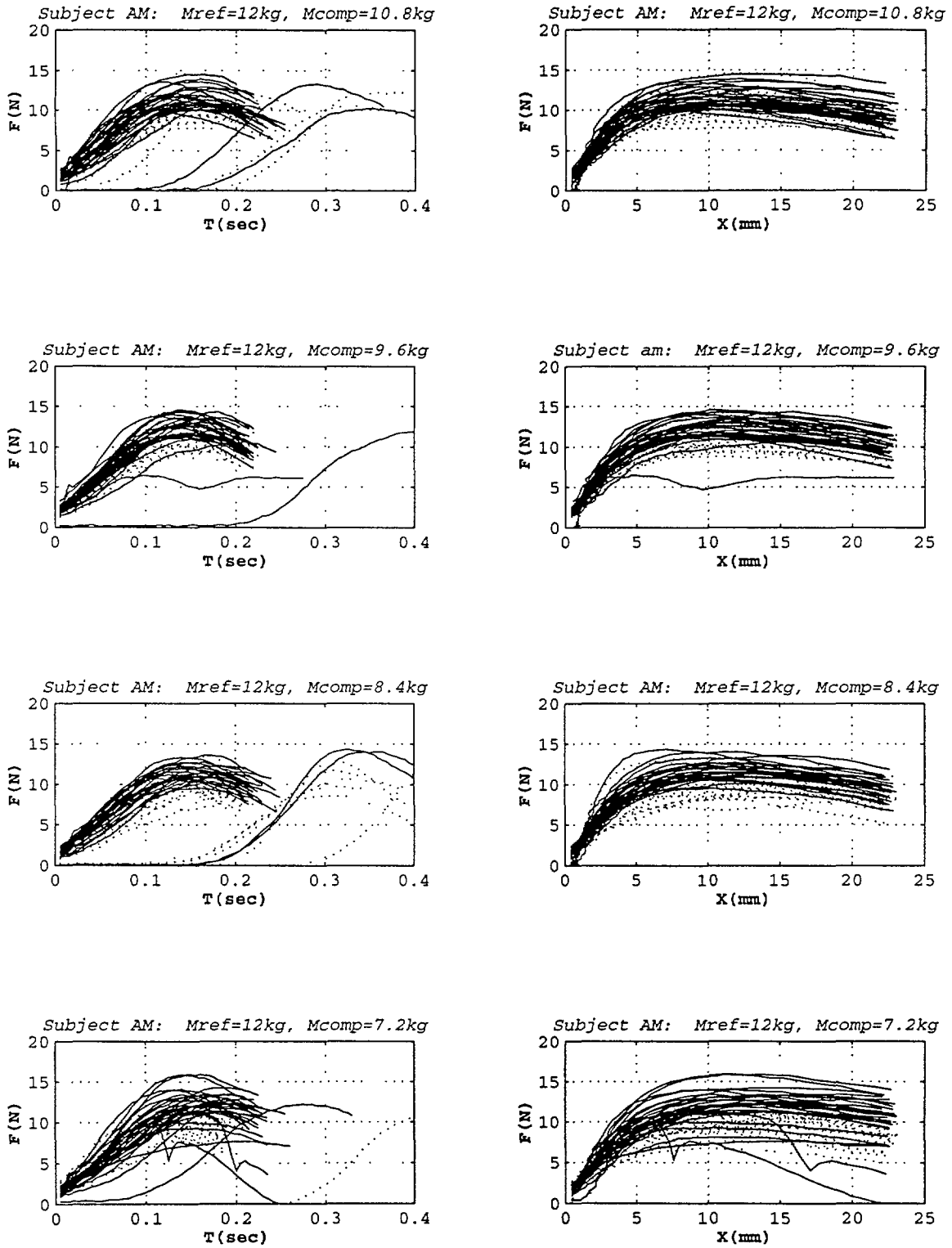

Figure C.3: Force Data for Subject AM with Reference Mass = 12kg. Force data plotted versus time and squeezing distance for all stimulus pairs. Solid lines are for trials where the reference was presented and dotted lines represent trials where the comparison was presented.

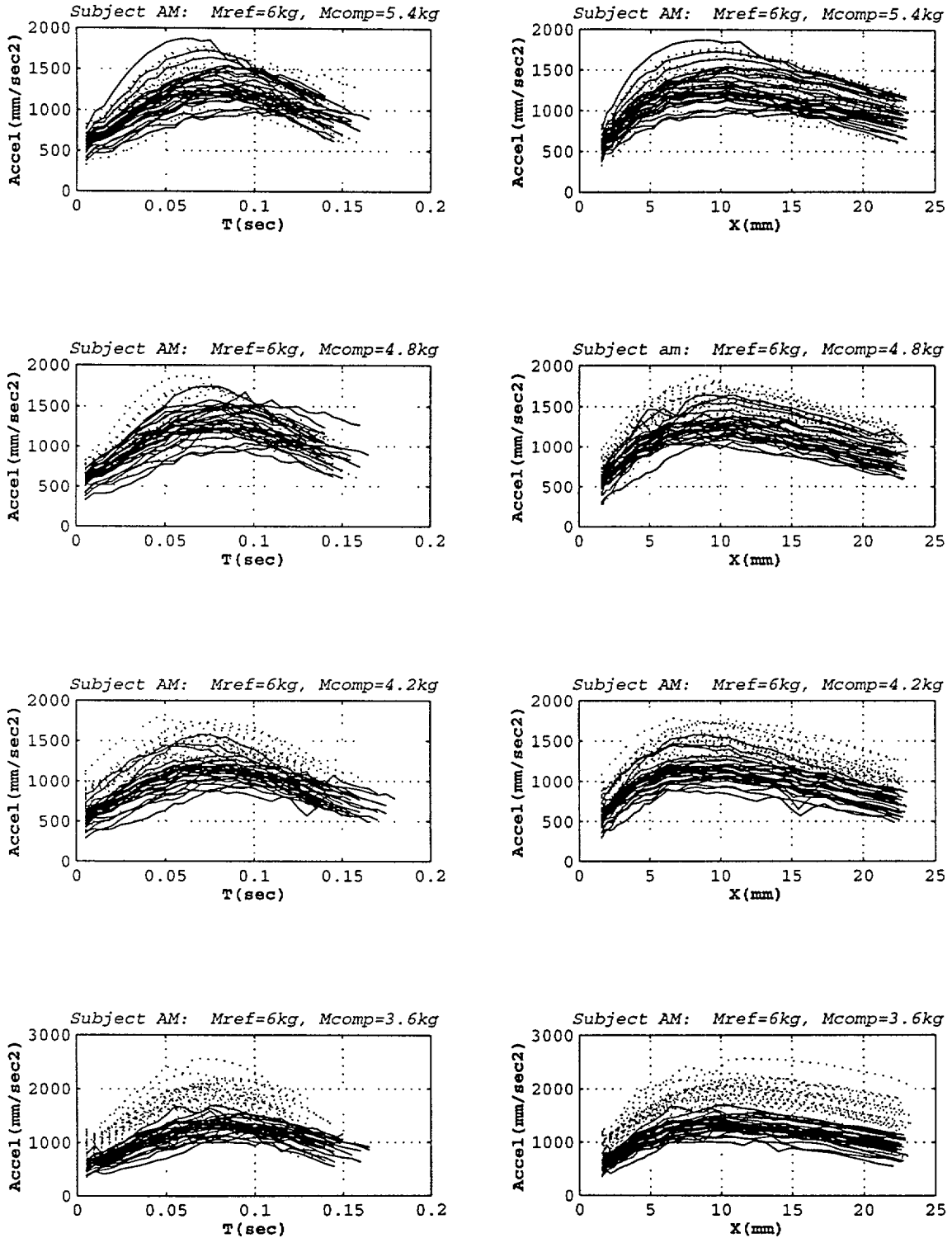

Figure C.4 Acceleration Data for Subject AM with Reference Mass = 6kg. Acceleration data plotted versus time and squeezing distance for all stimulus pairs. Solid lines are for trials where the reference was presented and dotted lines represent trials where the comparison was presented.

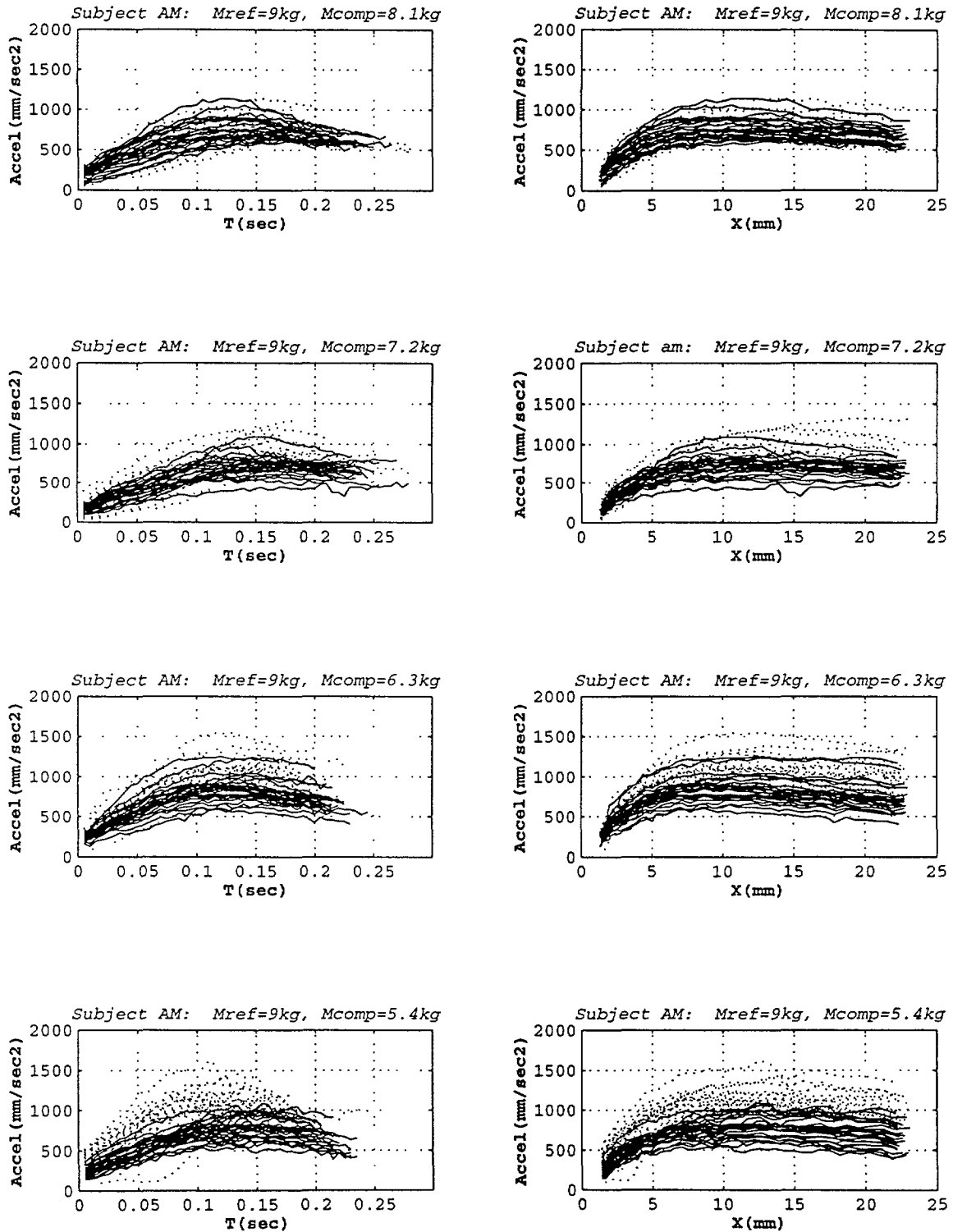

Figure C.5: Acceleration Data for Subject AM with Reference Mass = 9kg. Acceleration data plotted versus time and squeezing distance for all stimulus pairs. Solid lines are for trials where the reference was presented and dotted lines represent trials where the comparison was presented.

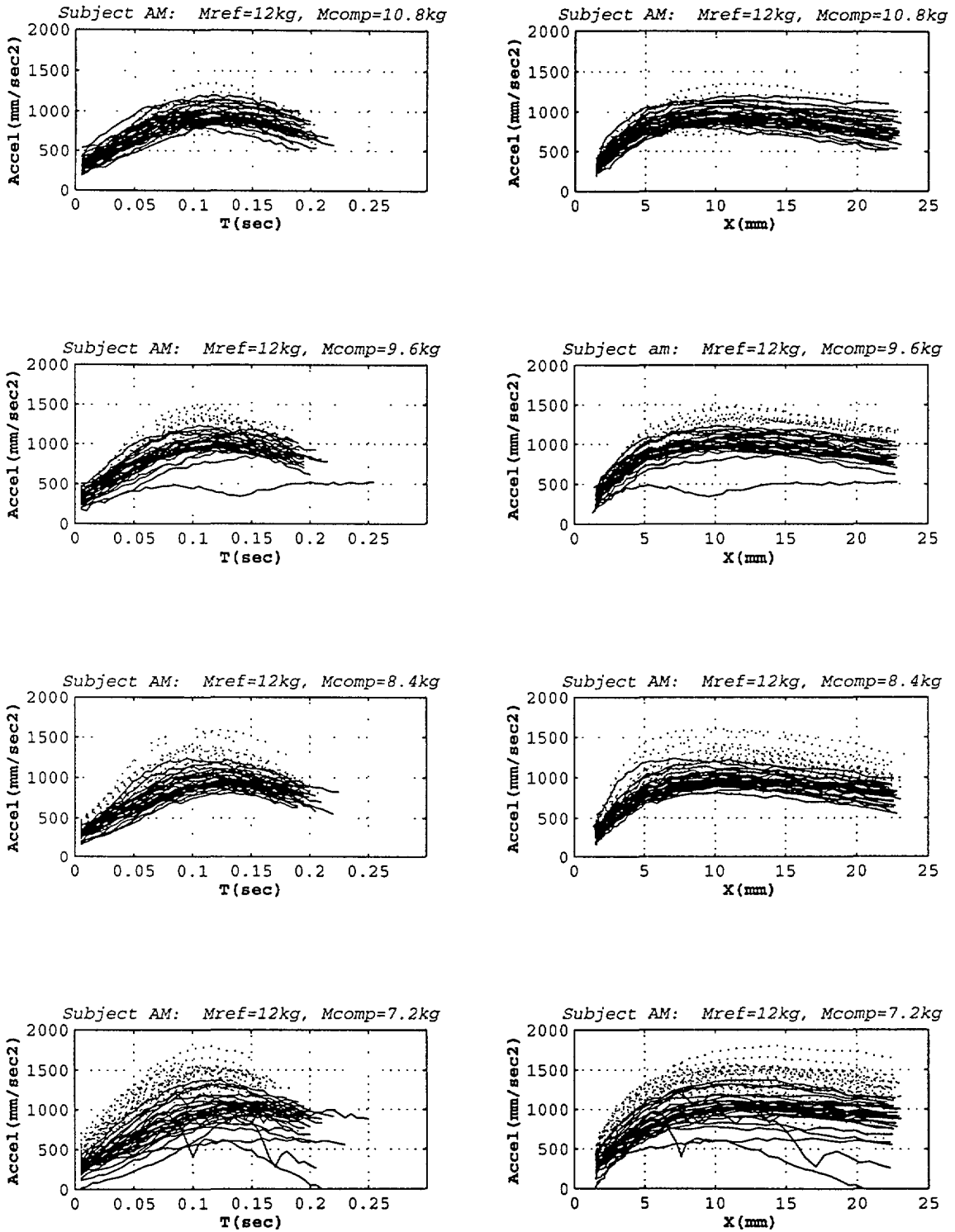

Figure C.6: Acceleration Data for Subject AM with Reference Mass = 12 kg. Acceleration data plotted versus time and squeezing distance for all stimulus pairs. Solid lines are for trials where the reference was presented and dotted lines represent trials where the comparison was presented.

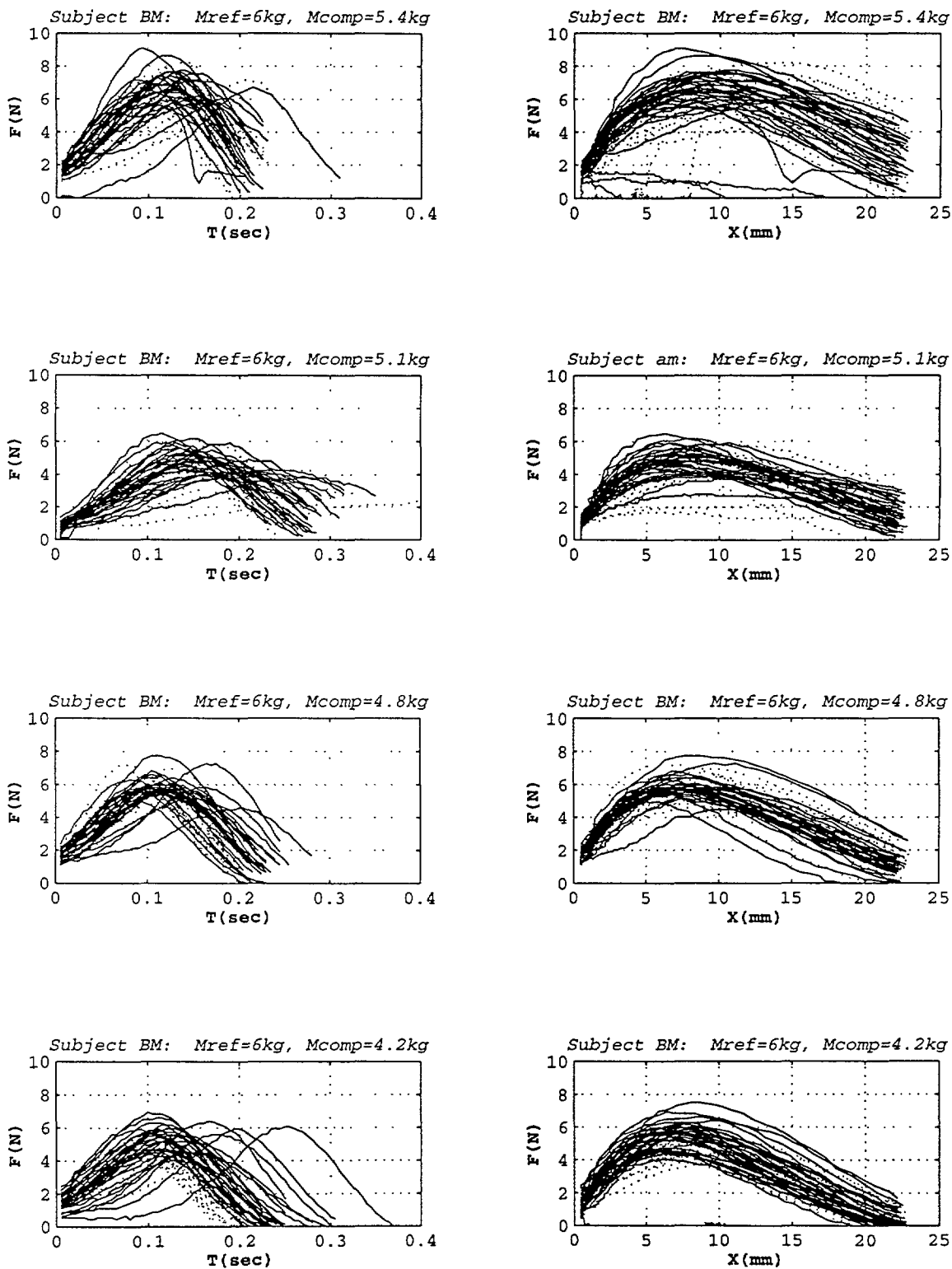

Figure C.7: Force Data for Subject BM with Reference Mass = 6kg. Force data plotted versus time and squeezing distance for all stimulus pairs. Solid lines are for trials where the reference was presented and dotted lines represent trials where the comparison was presented.

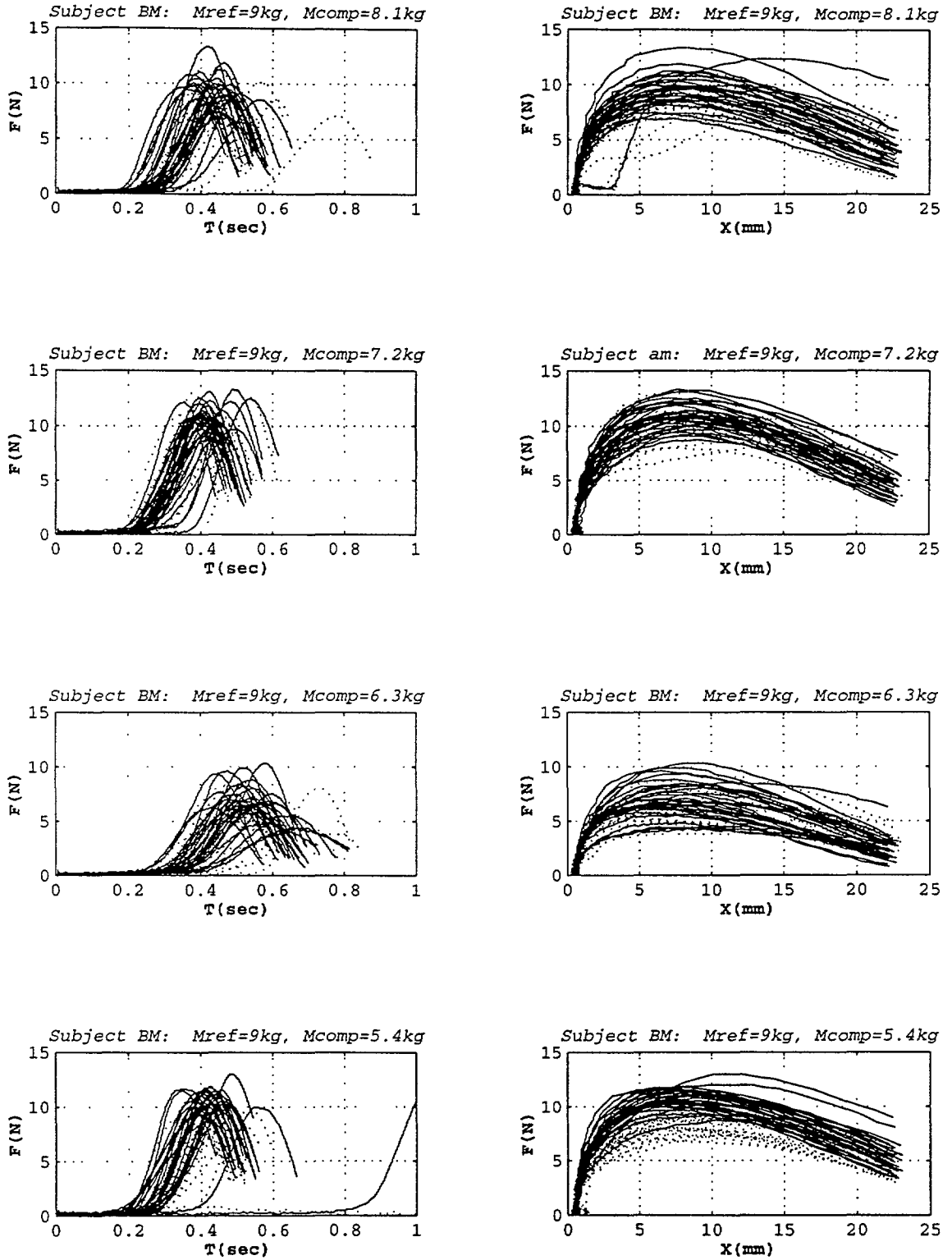

Figure C.8: Force Data for Subject BM with Reference Mass =9kg. Force data plotted versus time and squeezing distance for all stimulus pairs. Solid lines are for trials where the reference was presented and dotted lines represent trials where the comparison was presented.

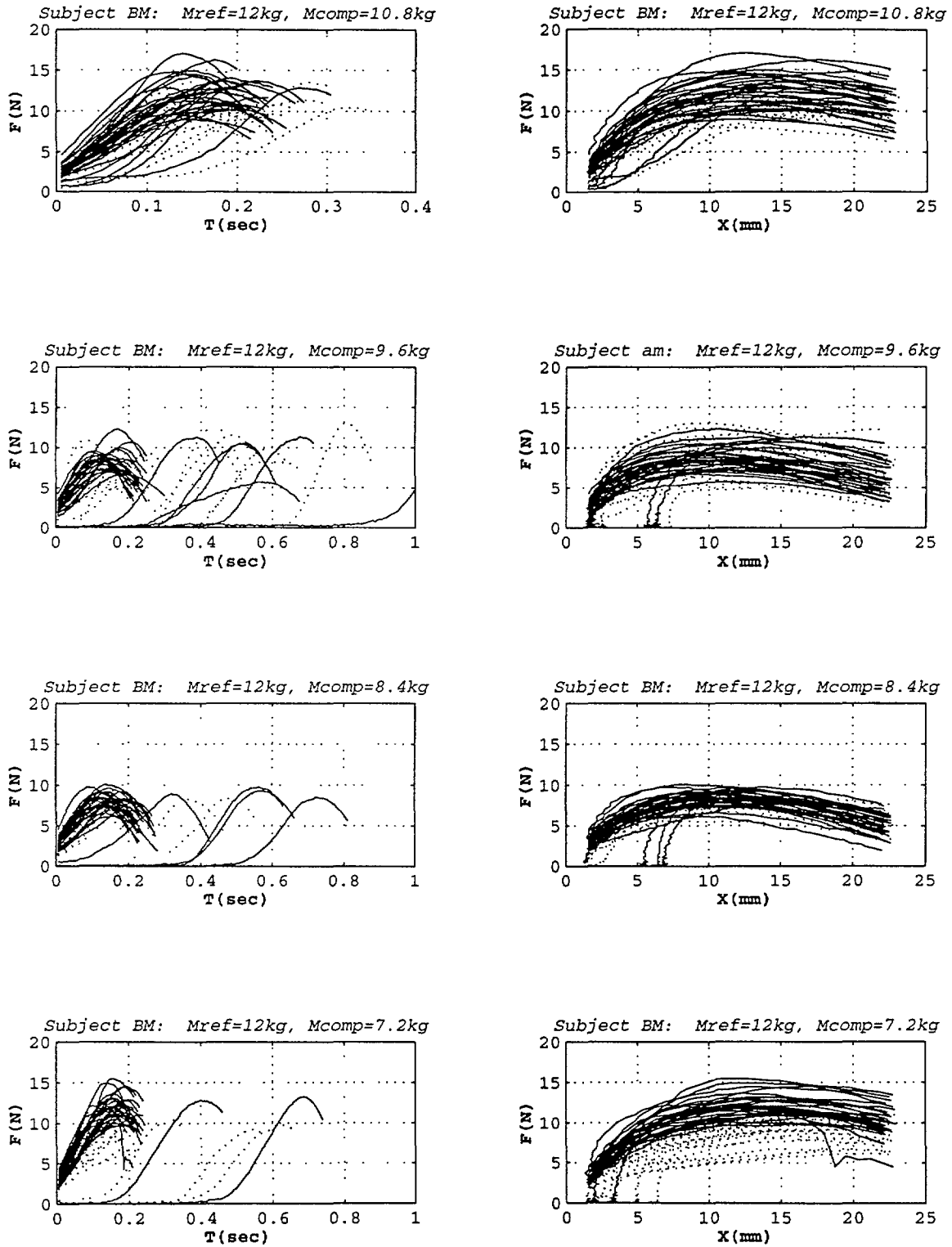

Figure C.9: Force Data for Subject BM with Reference Mass = 12kg. Force data plotted versus time and squeezing distance for all stimulus pairs. Solid lines are for trials where the reference was presented and dotted lines represent trials where the comparison was presented.

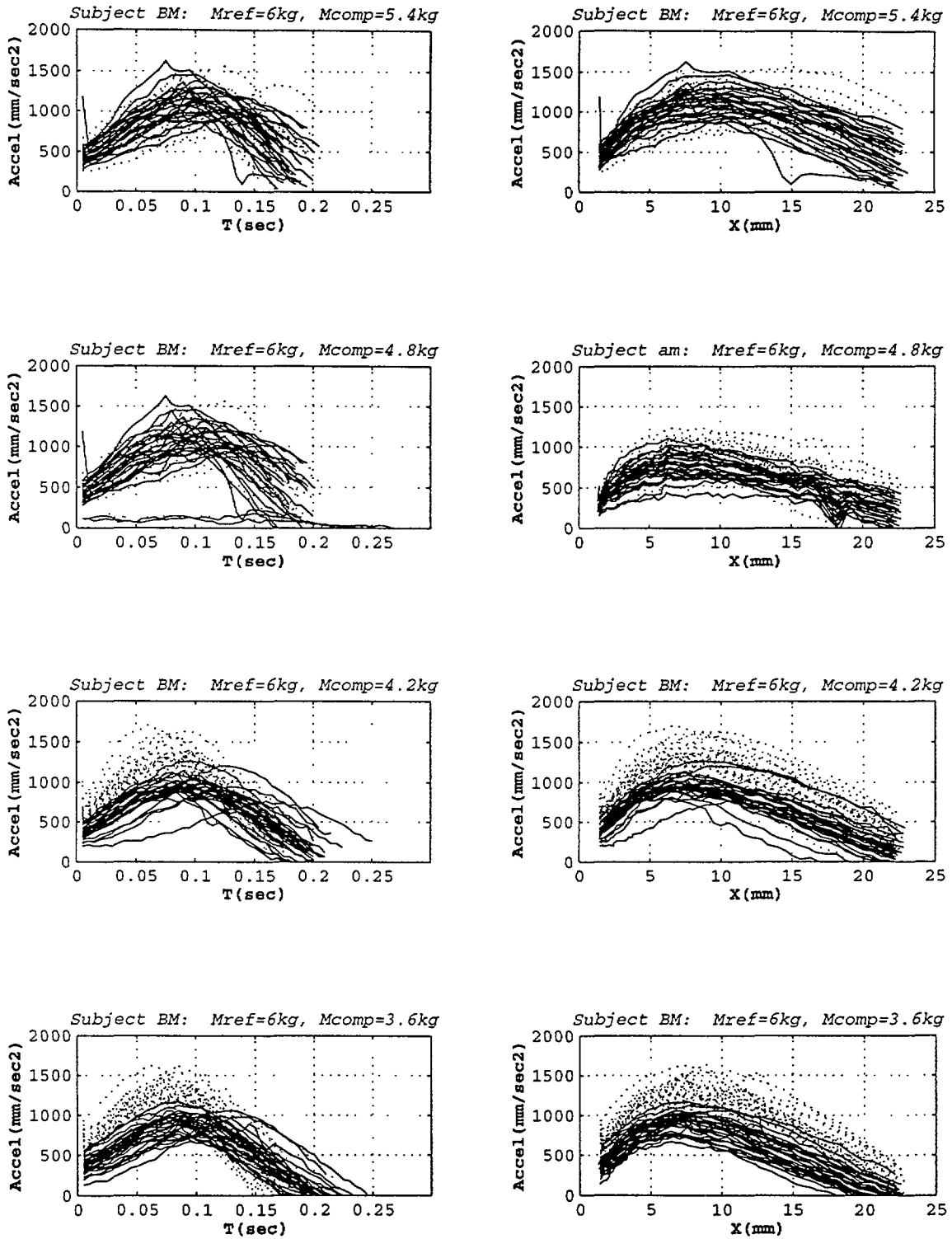

Figure C.10 Acceleration Data for Subject BM with Reference Mass = 6kg. Acceleration data plotted versus time and squeezing distance for all stimulus pairs. Solid lines are for trials where the reference was presented and dotted lines represent trials where the comparison was presented.

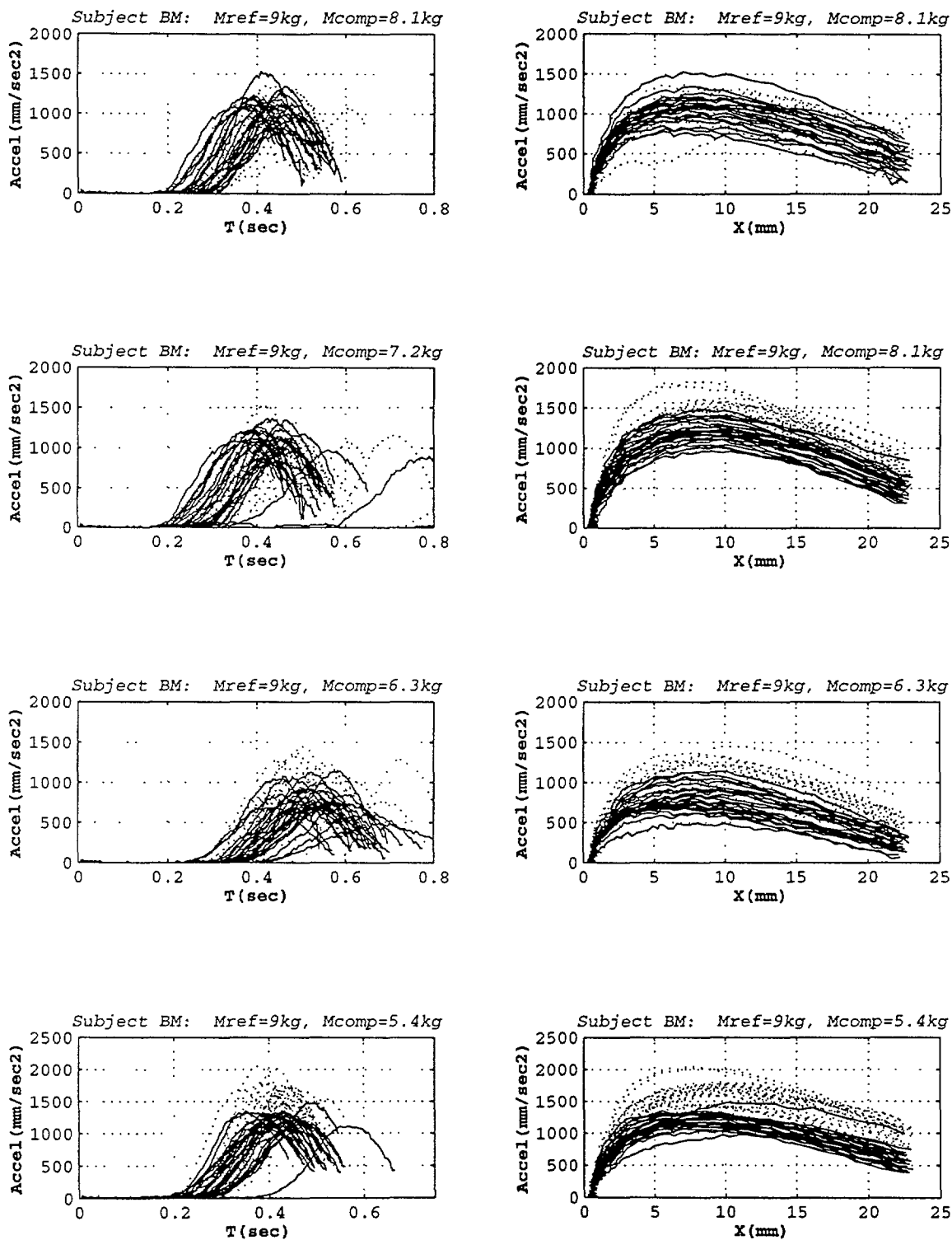

Figure C.11: Acceleration Data for Subject BM with Reference Mass = 9kg. Acceleration data plotted versus time and squeezing distance for all stimulus pairs. Solid lines are for trials where the reference was presented and dotted lines represent trials where the comparison was presented.

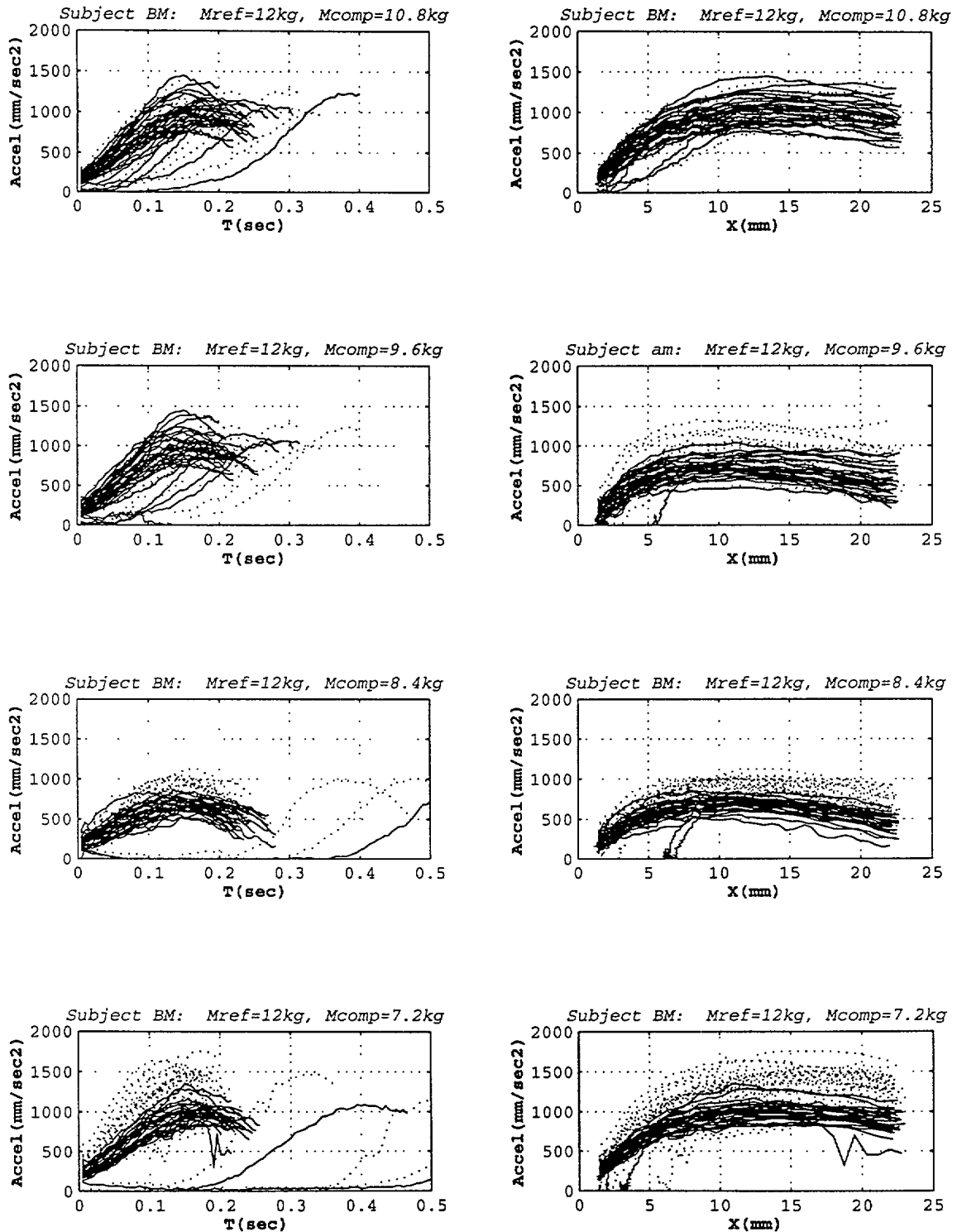

Figure C.12: Acceleration Data for Subject BM with Reference Mass = 12 kg. Acceleration data plotted versus time and squeezing distance for all stimulus pairs. Solid lines are for trials where the reference was presented and dotted lines represent trials where the comparison was presented.

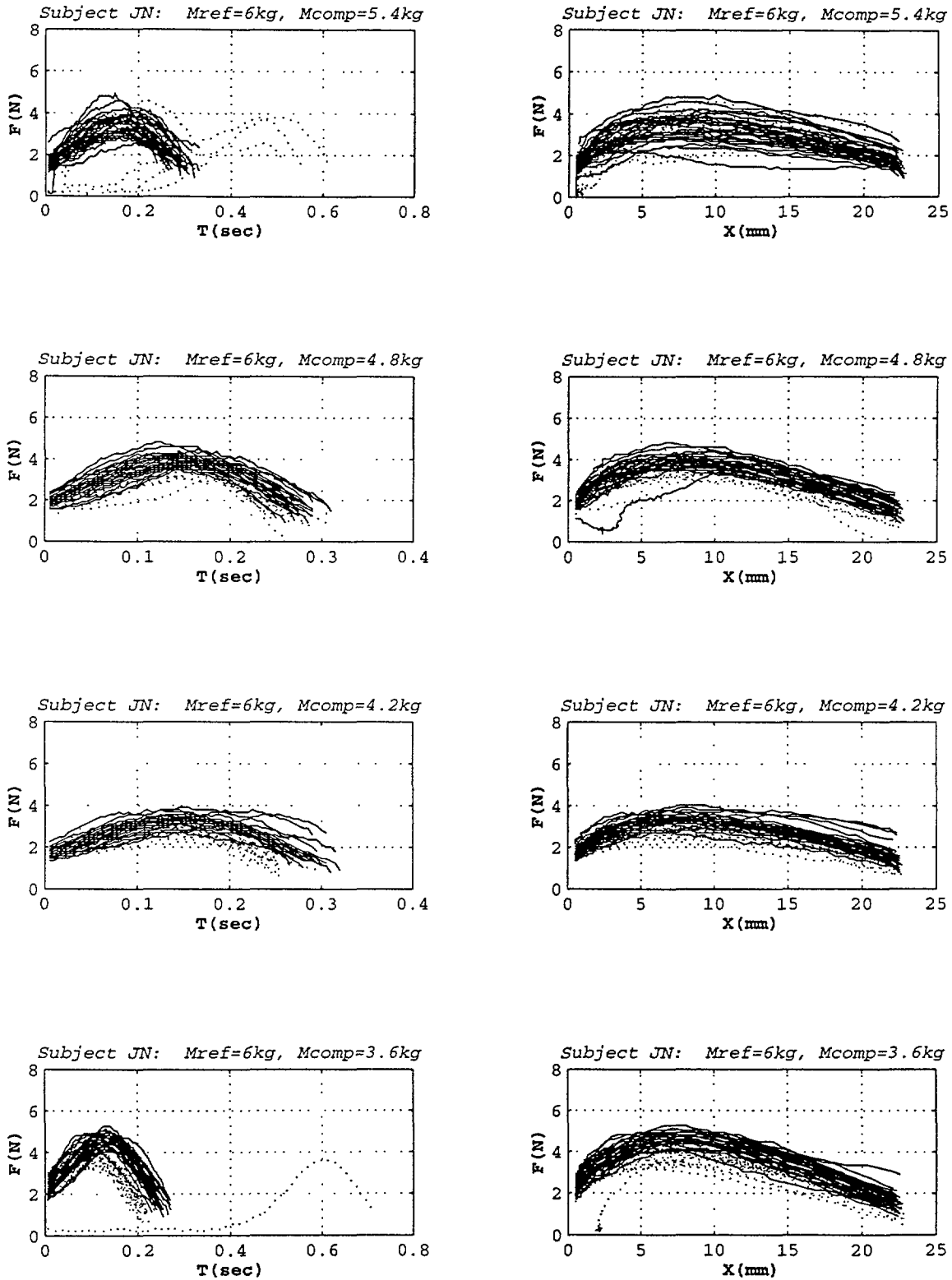

Figure C.13: Force Data for Subject JN with Reference Mass = 6kg. Force data plotted versus time and squeezing distance for all stimulus pairs. Solid lines are for trials where the reference was presented and dotted lines represent trials where the comparison was presented.

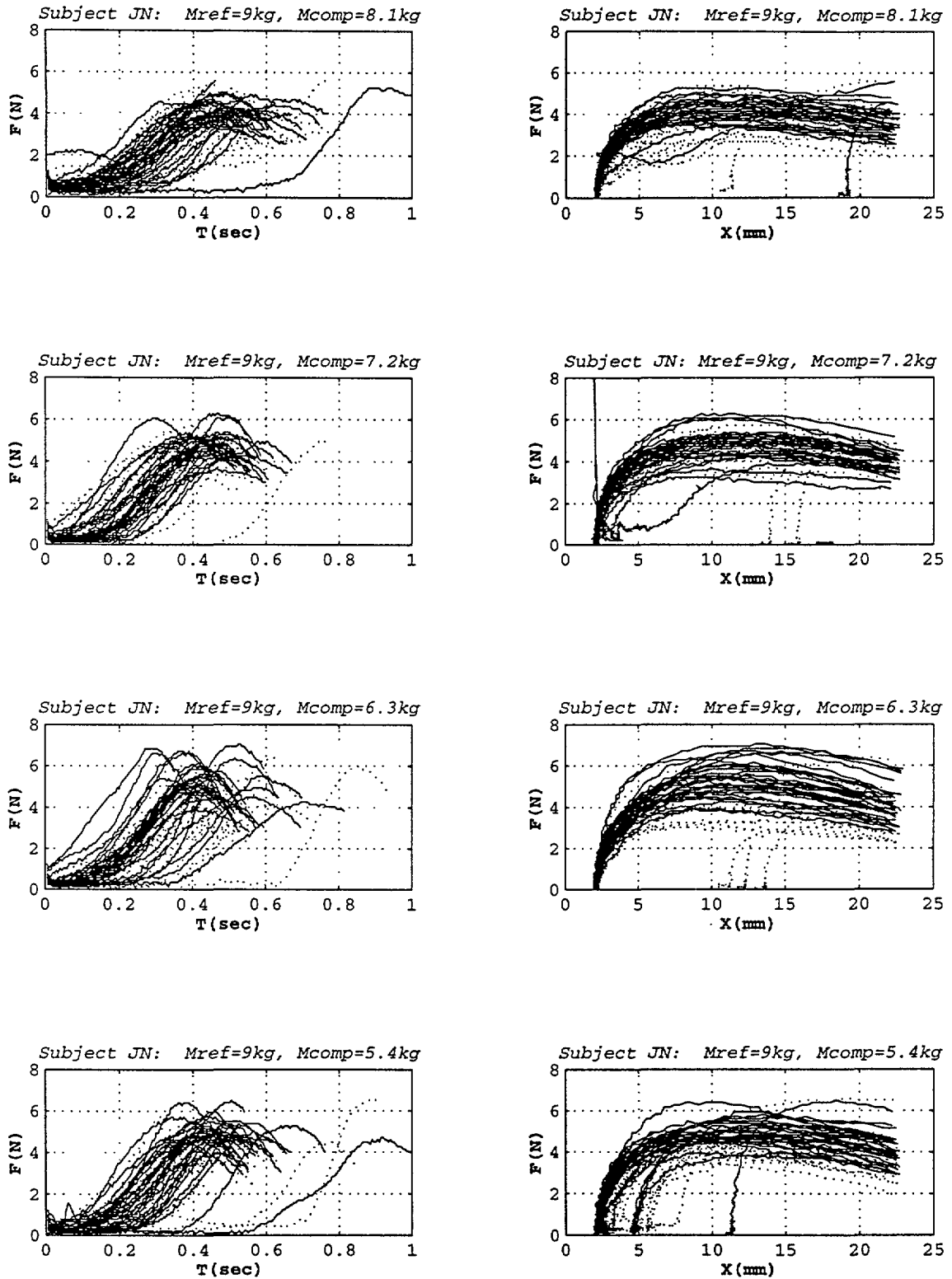

Figure C.14: Force Data for Subject JN with Reference Mass =9kg. Force data plotted versus time and squeezing distance for all stimulus pairs. Solid lines are for trials where the reference was presented and dotted lines represent trials where the comparison was presented.

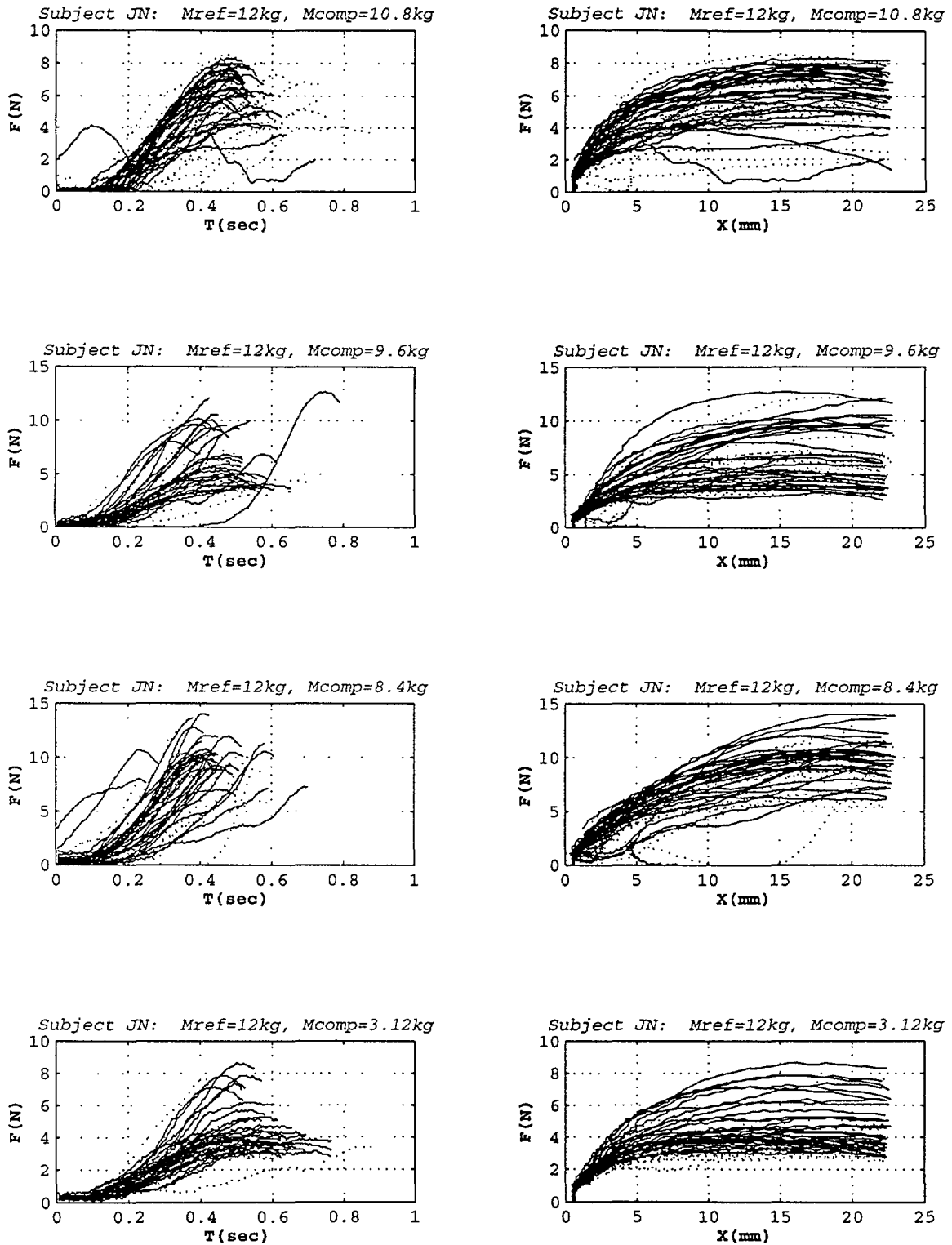

Figure C.15: Force Data for Subject JN with Reference Mass = 12kg. Force data plotted versus time and squeezing distance for all stimulus pairs. Solid lines are for trials where the reference was presented and dotted lines represent trials where the comparison was presented.

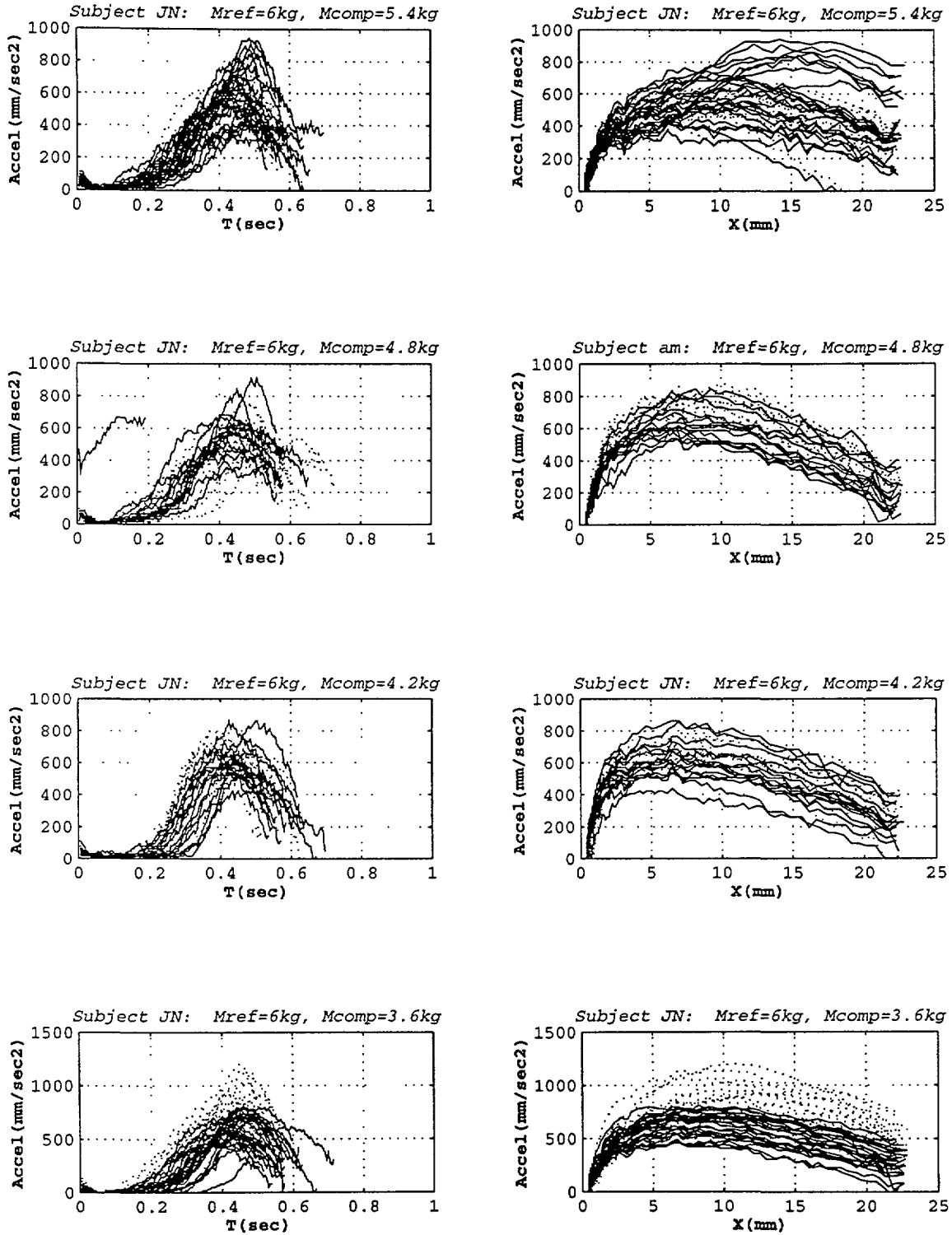

Figure C.16 Acceleration Data for Subject JN with Reference Mass = 6kg. Acceleration data plotted versus time and squeezing distance for all stimulus pairs. Solid lines are for trials where the reference was presented and dotted lines represent trials where the comparison was presented.

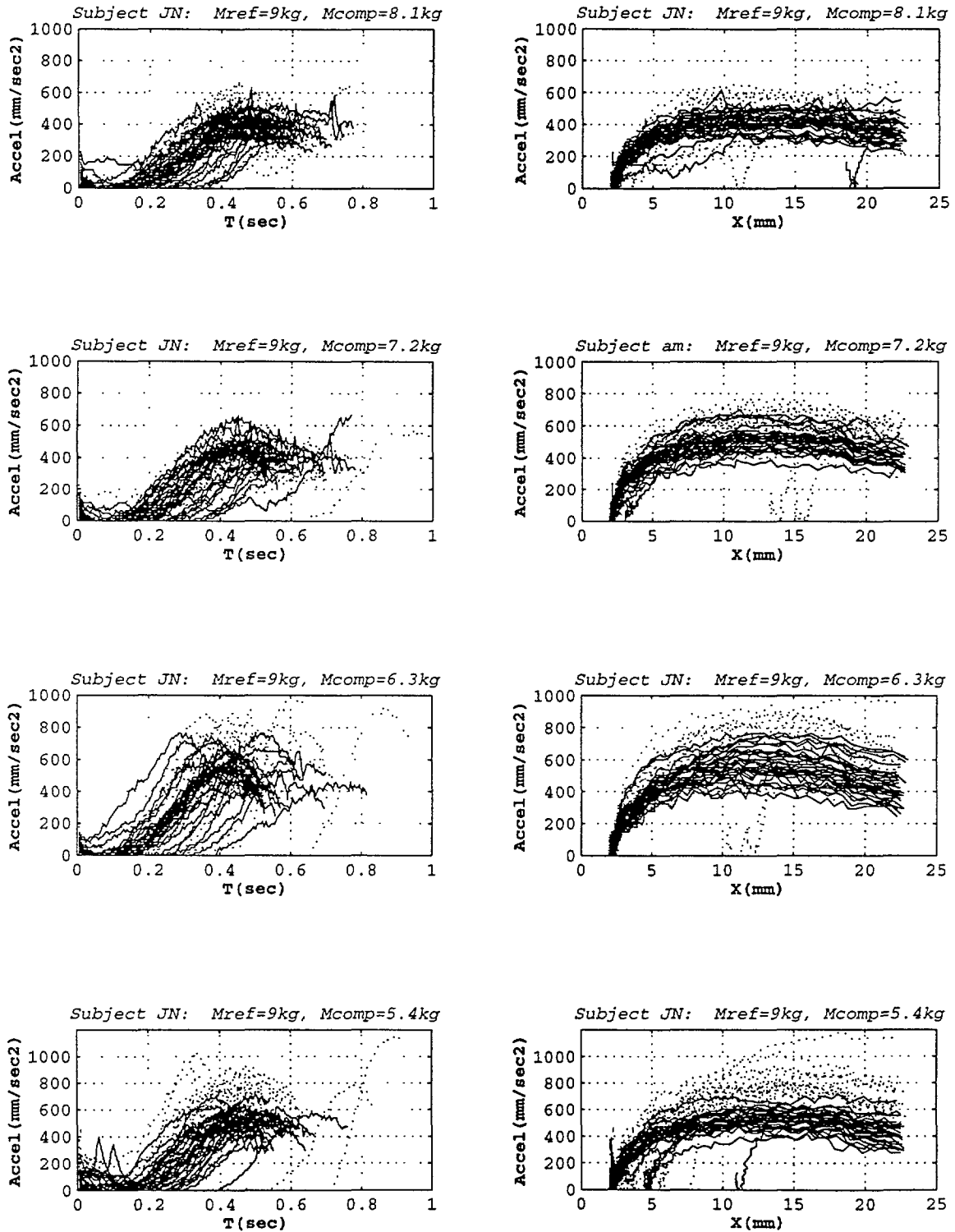

Figure C.17: Acceleration Data for Subject JN with Reference Mass = 9kg. Acceleration data plotted versus time and squeezing distance for all stimulus pairs. Solid lines are for trials where the reference was presented and dotted lines represent trials where the comparison was presented.

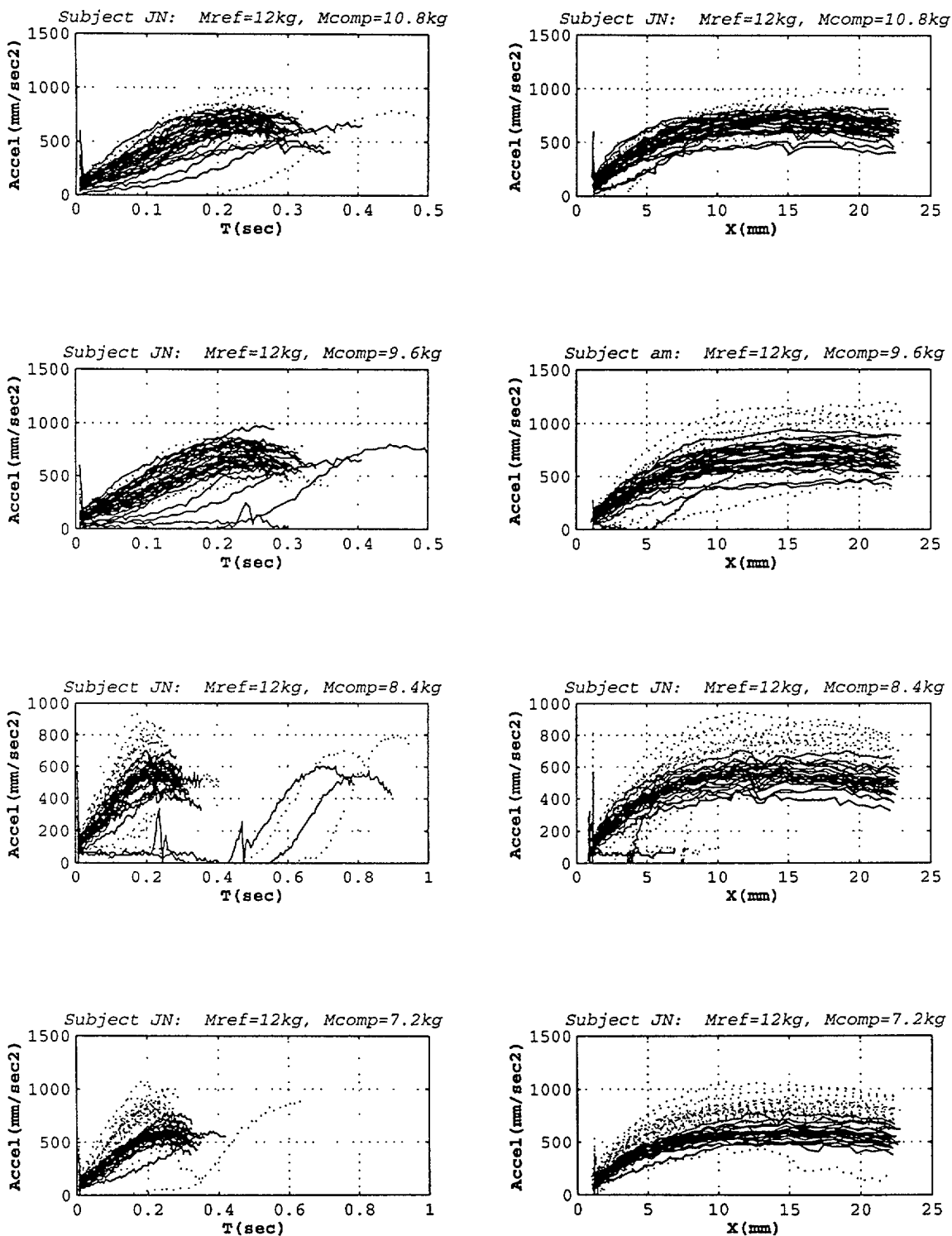

Figure C.18: Acceleration Data for Subject JN with Reference Mass = 12 kg. Acceleration data plotted versus time and squeezing distance for all stimulus pairs. Solid lines are for trials where the reference was presented and dotted lines represent trials where the comparison was presented.

Appendix D

Discrimination Experiments: Software Algorithms

Viscosity/Mass Discrimination Software:

```
/*
*****
* File: dashd25.c
*
* Copyright 1994 MIT Research Laboratory for Electronics
*
* Contents: Linear Dashpot/Viscosity Discrimination Experimental Software
* Created: 05/04/94
* Author: Lee Beauregard
* Revision: 4.1 (4/27/95)
*
* Remarks: presents 1I 2AFC viscosity stimuli at 1 KHZ with a
* fixed displacement of 25mm & logs position, velocity, acceleration
* and force at a 200 hz sampling rate into MAT-file format.
*****/

/* INCLUDE FILES
*****/
#include "stdio.h"
#include "stdlib.h"
#include "dos.h"
#include "alloc.h"
#include "time.h"
#include "/ASO1600/C/userprot.h"

/* LOCAL VARIABLES
*****/
DDH DAS1600; /* Device Handle */
char NumOfBoards; /* Number of boards in DAS1600.cfg */
int Err; /* Function return error flag */
int da_value; /* Storage for D/A value */
long ad_value; /* Storage for A/D value */
```

```

/* CONSTANTS
*****/
#define DEFAULT_FILE      "dashpot.cfg"
#define BASE 0x300        // base address of das 1600 board
#define COUNT_1 0x0d      // counter 1 address
#define COUNT_2 0x0e      // counter 2 address
#define CONTROL 0x0f      // timer control byte address

/* TYPES
*****/
typedef struct config_info {
    int      num_trials;    /* Number of trials */
    int      *trial;        /* Stiffness i */
    double   stiff_1;       /* Viscosity Stimulus 1 */
    double   stiff_2;       /* Viscosity Stimulus 2 */
    int      feedback;      /* Feedback status flag */
    char     subject_name[40]; /* Subject's name */
    char     test_date[40];   /* Date of Experiment */
    char     hand[40];        /* Hand evaluated */
    char     age[20];         /* Subject's age */
    char     test_type[40];   /* Type of experiment */
    char     experimenter[40]; /* Experiementer's name */
} CONFIG_INFO;

/* LOCAL FUNCTIONS
*****/
void initialize_hardware();
void initialize_timer();
void cursor_off();
void cursor_on();
void motor_output();
void print_config();
void print_labels();
void read_config();
double read_velocity();
double read_force();
double read_position();
double read_accel();
double actual_mm( double xdc );
double actual_velocity( double v_dc );
double actual_newtons( double f_vdc );
double actual_accl( double a_dc );
int  rnd_stim(int n, int *s);
int  rnd_position();

CONFIG_INFO *create_config();

/* LOCAL VARIABLES
*****/
CONFIG_INFO *config; /* Configuration information */

/* MAIN
*****/
void main(argc, argv)
    int      argc;          /* number of command line arguments */

```



```

char    *argv[];          /* command line arguments */
{
FILE    *fp,*ptr;        /* data and reponse file pointers */
time_t  t;
double  v_vdc;           /* velocity measured in volts dc */
double  a_vdc;           /* acceleration in volts */
double  x_vdc;           /* position in volts dc */
double  f_vdc;           /* force in volts dc */
double  position;        /* position (mm) */
double  velocity;        /* velocity in mm/s */
double  force;           /* force in newtons */
double  acceleration;    /* acceleration in mm/s/s */
double  f_offset,a_offset; /* force offset */
double  drive;           /* linear motor drive (v) */
double  drive_force;     /* driving force to be generated */
double  damping_coef;    /* damping coefficient (Ns/mm) */
double  position_data[1500]; /* position data array */
double  velocity_data[1500]; /* velocity data array */
double  force_data[1500];  /* force data array */
double  accel_data[1500]; /* acceleration data array */
double  select=0;         /* data logger selector */
double  stim_real[2];

int     value;           /* random number */
int     i,j,l, n_trial; /* trial number */
int     index;           /* index */
int     stim[256]        /* array holding stim presentation order */
int     x_data[256];     /* array holding roving distance values */
int     response[256];   /* array holding subject response order */
int     x_max;           /* maximum position to apply force */
int     c1=0, c2=0;      /* counters for correct stimuli detection */
int     missed1,missed2; /* counters for missed detections */
int     flag,wait,rate=0; /* flags for data logging */
int     delta_count;     /* count difference in timer routine */
int     delta=0,error=0; /* sampling rate error values */
int     old_count,new_count,dum; /* lsb,msb timer counter values */

char    filename[40];    /* filename */
char    datafile[40];    /* data file name */
char    matfile[40];     /* mat file name */
char    c;               /* subject's response */

char    xmat[4] ;        /*MAT file variables */
char    fmat[4];
char    vmat[4];
char    amat[4];
char    string[3];
char    *posx="x";
char    *forf="f";
char    *velv="v";
char    *acca="a";
double  trial[64];
double  resp[64];

/* Configuration information */
if (argc >= 3) {

```

```

strcpy(filename, argv[1]);
strcpy(datafile, argv[2]);
strcpy(matfile, argv[3]);
}
else {
strcpy(filename, DEFAULT_FILE);
strcpy(datafile, "dashpot.dat");
strcpy(matfile, "dash.mat");
}
config = create_config();
read_config(filename);
n_trial = config->num_trials;
rnd_stim(n_trial, stim); // generate random stim array
clrscr();
strcpy(xmat, posx);
strcpy(fmat, forf);
strcpy(vmat, velv);
strcpy(amat, acca);

// DETERMINE FORCE OFFSET

initialize_hardware();
drive=0.0;
motor_output(drive);

printf("Hit the space bar for force sensor calibration\n");
while( !kbhit());
c = getch();

force = read_force();
f_offset = -21.195*force;
a_vdc = read_accel();
a_offset = 3331.8*a_vdc;

for (n_trial = 0; n_trial < config->num_trials; n_trial++) {

initialize_timer();

// RESET GRASPER TO HOME POSITION

drive = -0.10;
motor_output(drive);
x_vdc = read_position();
position = actual_mm( x_vdc );
while ( (!kbhit()) & (position > 1.5)){
x_vdc = read_position();
position = actual_mm( x_vdc );
}

cursor_off();
print_labels(n_trial);

/* RANDOMIZE BETWEEN 2 DAMPING COEFFICIENTS */

if (stim[n_trial] == 1)
damping_coeff = config->stiff_1;

```

```

else
    damping_coeff = config->stiff_2;

x_max = 10.0; // fixed displacement of 35mm
x_data[n_trial] = x_max; // record distance
x_vdc = read_position(); // measure initial position
position = actual_mm( x_vdc );
select = 0.0; // data log every fourth trial
wait = 1; // wait used to store data at 500hz
l = 0; // reset data array subscript
flag = 1;

/* CONTROL LOOP */

while( position < x_max ) {

if ( flag == 1 ){
    outportb( BASE + CONTROL, 0x80 ); // control byte to read C2 status
    old_count = inportb( BASE + COUNT_2 ); // read lsb
    dum = inportb( BASE + COUNT_2 ); // dummy msb read
    flag = 0;
}

do{
    outportb( BASE + CONTROL, 0x80 ); // wait loop for 1msec
    new_count = inportb( BASE + COUNT_2 ); // control byte for C2
    dum = inportb( BASE + COUNT_2 ); // read lsb
    delta_count = old_count - new_count; // dummy read msb
} while ( delta_count == 0 );

/* READ SENSOR DATA */

v_vdc = read_velocity();
velocity = actual_velocity( v_vdc );
x_vdc = read_position();
position = actual_mm( x_vdc );
f_vdc = read_force();
force = actual_newtons( f_vdc ) - f_offset;
a_vdc = read_accel();
acceleration = actual_accl( a_vdc ) - a_offset;

/* CHECK COUNT VALUE FOR ONE DECREMENT */
if (( delta_count != 1 ) && (delta_count != -255 ) && (select == 0)){
// printf("Sampling rate error. Delta Count = %d\n",delta_count);
error = n_trial + 1;
delta = delta_count;
// cursor_on();
}

/* GENERATE DRIVE FORCE */
drive = 0.0;
drive_force = damping_coeff*velocity-0.5;
drive = -0.0670*drive_force; // convert force to volts */

if (drive_force < 30.0) motor_output(drive);

/* LOG DATA EVERY TRIAL */

```

```

    if (( l < 1500 ) && (rate == 0) && (select == 0.0)){
        velocity_data[l] = velocity;
        position_data[l] = position;
        force_data[l] = force;
        accel_data[l] = acceleration;
        l++;
    }

    wait++;
    rate = wait%5;
    old_count = new_count;

}

drive = 0.0;
motor_output(drive);

/*          RECORD SUBJECT'S RESPONSE          */

printf("Type '1' for the greater viscosity, Type '2' for the lesser viscosity \n");
c = getch();

while(( c != '1' ) & ( c != '2')){
    printf("Type '1' for the lesser viscosity, Type '2' for the lesser viscosity \n");
    c=getch();
}
switch( c ){
    case '1':
        response[n_trial] = 1;
        resp[n_trial] = 1.0;
        break;
    case '2':
        response[n_trial] = 2;
        resp[n_trial] = 2.0;
        break;
}

/*          FEEDBACK PRESENTATION          */

if (config->feedback == 1){
    if (response[n_trial] == stim[n_trial])
        printf("Correct Response\n");
    else printf("Incorrect Response\n");
}

/*          WRITE VELOCITY, FORCE AND POSITION DATA TO MAT-FILE
-----*/

if ((ptr=fopen(matfile, "a+b")) == NULL){
    printf("can not open file\n");
    return;
}

j=n_trial+1;
if (stim[n_trial] == 1) trial[n_trial]=1.0;

```

```

        else trial[n_trial]=2.0;

        itoa(j, string, 10);
        strcat(xmat, string);
        strcat(fmat, string);
        strcat(vmat, string);
        strcat(amat, string);
        savemat(ptr, 0, xmat, 1, 1, 0, position_data, (double *)0);
        savemat(ptr, 0, fmat, 1, 1, 0, force_data, (double *)0);
        savemat(ptr, 0, vmat, 1, 1, 0, velocity_data, (double *)0);
        savemat(ptr, 0, amat, 1, 1, 0, accel_data, (double *)0);
        savemat(ptr, 0, "trmat", 64, 1, 0, trial, (double *)0);      //array holding stim order
        savemat(ptr, 0, "rspmat", 64, 1, 0, resp, (double *)0);    //array holding response order
        fclose(ptr);
        strcpy(xmat, posx);
        strcpy(fmat, forf);
        strcpy(vmat, velv);
        strcpy(amat, acca);
        cursor_on();
    }
    drive = 0.0;
    motor_output(drive);

/*          WRITE TO RESPONSE DATA FILE          */

if ((fp=fopen(datafile,"a")) == NULL){
    printf("can not open file\n");
    return;
}
t = time(NULL);
if ( error > 0 ) fprintf(fp, "sample rate error at trial %d\t delta = %d\n",error,delta);
fprintf(fp, "%s\n", config->subject_name);
fprintf(fp, "%s\n", config->age);
fprintf(fp, "%s\n", config->hand);
fprintf(fp, "%s", ctime(&t));
fprintf(fp, "%s\n", config->test_date);
fprintf(fp, "%s\n", config->test_type);
fprintf(fp, "%s\n", config->experimenter);
fprintf(fp, "Feedback Status (1=on 0=off): %d\n", config->feedback);
fprintf(fp, "Reference Damping:\t %4.3f\n", config->stiff_1);
fprintf(fp, "Damping #2:\t %4.3f\n", config->stiff_2);
fprintf(fp, "TRIAL#\t STIMULUS\t RESPONSE\t ROVING DISPLACEMENT\n");
for ( i=0; i < config->num_trials; i++) {
    j=i+1;
    fprintf(fp, "%3.1d\t %5.1d\t %12.1d\t %18.1d\n",j,stim[i],response[i],x_data[i]);
}
fprintf(fp, "\n");

/* CALCULATE CONFUSION MATRIX AND WRITE TO DATA FILE */
for (n_trial = 0; n_trial < config->num_trials; n_trial++) {
    if (stim[n_trial] == 1){
        if (stim[n_trial] == response[n_trial]) c1=c1+1;
    }
    if (stim[n_trial] == 2){
        if (stim[n_trial] == response[n_trial]) c2=c2+1;
    }
}

```

```

    }
    missed1 = (config->num_trials)/2 - c1;
    missed2 = (config->num_trials)/2 - c2;
    fprintf(fp, "Damping 1 was correctly detected %d times\n", c1);
    fprintf(fp, "Damping 1 was missed %d times\n", missed1);
    fprintf(fp, "Damping 2 was correctly detected %d times\n", c2);
    fprintf(fp, "Damping 2 was missed %d times\n", missed2);
    fprintf(fp, "\n");
    fclose(fp);
    cursor_on();
}
//      FUNCTIONS USED IN ALL DISCRIMINATION EXPERIMENTS

/* INITIALIZE HARDWARE
----- */
void initialize_hardware()
{
    /* Initialize the hardware/software */
    if ((Err = DAS1600_DevOpen("DAS1600.CFG", &NumOfBoards)) != 0) {
        fprintf(stderr, "test error: %x during DevOpen\n", Err);
        exit(Err);
    }

    /* Establish communication with the driver */
    if ((Err = DAS1600_GetDevHandle(0, &DAS1600)) != 0) {
        fprintf(stderr, "test error: Error %x during GetDevHandle\n", Err);
        exit(Err);
    }
}

/* CREATE CONFIG
----- */
CONFIG_INFO *create_config()
{
    CONFIG_INFO *config;

    config = (CONFIG_INFO *) malloc(sizeof(CONFIG_INFO));
    return(config);
}

/* READ CONFIG
----- */
void read_config(filename)
char *filename;
{
    char temp[40];
    double value;

    FILE *fp;

    if ((fp = fopen(filename, "r")) == NULL) {
        fprintf(stderr, "read_config error: unable to open file %s\n", filename);
        exit(1);
    }
    fscanf(fp, "%s %d", temp, &(config->num_trials));
}

```

```

config->trial = (int *) malloc(config->num_trials*sizeof(int));
fscanf(fp, "%s %lf", temp, &value);
config->stiff_1 = value;
fscanf(fp, "%s %lf", temp, &value);
config->stiff_2 = value;
fscanf(fp, "%s %d", temp, &(config->feedback));
fscanf(fp, "%s", &(config->subject_name));
fscanf(fp, "%s", &(config->age));
fscanf(fp, "%s", &(config->hand));
fscanf(fp, "%s", &(config->test_date));
fscanf(fp, "%s", &(config->test_type));
fscanf(fp, "%s", &(config->experimenter));
}
/* PRINT CONFIG
----- */
void print_config()
{
    printf("%lf\n", config->stiff_1);
    printf("%lf\n", config->stiff_2);
    printf("%d\n", config->feedback);
}

/* PRINT LABELS
----- */
void print_labels(n_trial)
    int    n_trial;
{
    /* gotoxy(10, 3); */

    printf("\n");
    printf("DASHPOT TRIAL No. %d\n", n_trial+1);

    /* gotoxy(2, 8);
    printf("Position (mm): ");
    gotoxy(2, 10);
    printf(" Force (N): ");
    gotoxy(2, 12);
    printf(" Drive (v): "); */
}

/* READ POSITION
----- */
double read_position()
{
    /* Read channel 0 at gain 1; store sample in ad_value */
    if ((Err = K_ADRead(DAS1600, 0, 0, &ad_value)) != 0) {
        fprintf(stderr, " test error: Error in K_ADRead operation\n");
        exit(Err);
    }
    return(((double) ((ad_value >> 4) - 2048))/204.8);
}
/* READ FORCE
----- */
double read_force()
{
    /* Read channel 2 at gain 8; store sample in ad_value */

```

```

if ((Err = K_ADRead(DAS1600, 2, 3, &ad_value)) != 0) {
    fprintf(stderr, " test error: Error in K_ADRead operation\n");
    exit(Err);
}
return(((double) ((ad_value >> 4) - 2048))/204.8);
}

/* READ ACCELERATION
----- */
double read_accel()
{
/* Read channel 3 at gain 1; store sample in ad_value */
if ((Err = K_ADRead(DAS1600, 3, 0, &ad_value)) != 0) {
    fprintf(stderr, " test error: Error in K_ADRead operation\n");
    exit(Err);
}
return(((double) ((ad_value >> 4) - 2048))/204.8);
}

/* READ VELOCITY
----- */
double read_velocity()
{
/* Read channel 1 at gain 1; store sample in ad_value */
if ((Err = K_ADRead(DAS1600, 1, 0, &ad_value)) != 0) {
    fprintf(stderr, " test error: Error in K_ADRead operation\n");
    exit(Err);
}
return(((double) ((ad_value >> 4) - 2048))/204.8);
}

/* MOTOR OUTPUT
----- */
void motor_output(drive)
double drive; /* motor output (volts) */
{
    da_value = ((int) (drive*204.8) + 2048) << 4;

/* OUTPUT DAvalue TO DAC #0 */
if ((Err = K_DAWrite (DAS1600, 0, da_value)) != 0) {
    fprintf (stderr, "test error: Error in K_DAWrite operation.");
    exit(1);
}
}

/* CURSOR OFF
----- */
void cursor_off()
{
    union REGS in_regs, out_regs;

    in_regs.h.ah = 0x01;
    in_regs.h.ch = 0x10;
    in_regs.h.cl = 0x00;
    int86(0x10, &in_regs, &out_regs);
}

```



```

/* CURSOR ON
-----*/
void cursor_on()
{
    union REGS in_regs, out_regs;

    in_regs.h.ah = 0x01;
    in_regs.h.ch = 0x10;
    in_regs.h.cl = 0x10;
    int86(0x10, &in_regs, &out_regs);
}

/* ACTUAL_ACCL
-----
    converts accelerometer voltage to mm/sec/sec */
double actual_accl( double a_dc )
{
    double accelrate;

    accelrate = 3331.8*a_dc;
    return( accelrate );
}
/* ACTUAL_MM
-----
    converts voltage measurement of position into actual mm traveled */
double actual_mm( double xdc )
{
    double x_mm;

    x_mm = 24.955*xdc + 53.77;

    return( x_mm );
}
/* ACTUAL_VELOCITY
-----
    converts velocity voltage measurement to mm/sec */
double actual_velocity( double v_dc )
{
    double speed;

    speed = -31.4735*v_dc - 1.26; // away from rest is positive velocity

    return ( speed );
}

/*ACTUAL_NEWTONS
-----
    converts force voltage measurement in actual force in newtons */
double actual_newtons( double f_vdc )
{
    double f_newton;

```

```

        f_newton = -21.195*f_vdc;

return ( f_newton );
}
/*TIMER INITIALIZATION ROUTINE
-----*/
void initialize_timer()
{
    // counter1 is a divide-by-n counter

    outportb( BASE + CONTROL, 0x74 ); // set counter1 control byte
    outportb( BASE + COUNT_1, 0x10 ); // set n = 10,000
    outportb( BASE + COUNT_1, 0x27 ); // by loading least sign. byte first

    outportb( BASE + CONTROL, 0xc4 ); // set counter2 control byte
    outportb( BASE + COUNT_2, 0xff ); // set counter2 at 255
    outportb( BASE + COUNT_2, 0x00 ); // by loading lsb first
}
/*RANDOM POSITION GENERATOR
-----*/
rnd_position()
{
    int x;
    x = random (1000);
    if ( x < 200 ) return (15);
    if (( x >= 200 ) & ( x < 400 )) return (20);
    if (( x >= 400 ) & ( x < 600 )) return (25);
    if (( x >= 600 ) & ( x < 800 )) return (30);
    if ( x >= 800 ) return (35);
    return (0);
}

/*RANDOM STIMULUS GENERATOR
-----*/
rnd_stim(int n, int *s)
{
    int i,x,n1,z,y,j,k;

    z=0; y=0; n1=n/2; j=0; k=0;
    randomize();

    for(i=0; i<n; i++){
        x = random (20001);
        x %=2; // determine if rand num is odd or even
        if ( x == 0 ) { // if even.....
            if((y < n1 ) & ( j < 5 )){
                y++;
                j++;
                k=0;
                *s = 1;
                *s++;
            }
            else {
                z++;
                j=0;
                *s = 2;
            }
        }
    }
}

```

```

        *s++;
    }
    } // if odd.....
else {
    if ((z < n1) & (k < 5))
    {
        z++;
        k++; j=0;
        *s = 2;
        *s++;
    }
    else {
        y++;
        k=0;
        *s = 1;
        *s++;
    }
}
}
if (y==z) return (1); else return (0); /* return(1) if # of stim1=stim2 */
}

/* SAVE DATA IN MAT-FILE FORMAT
-----*/
savemat(ptr, type, pname, mrows, ncols, imagf, preal, pimag)

FILE *ptr; /* File pointer */
int type; /* Type flag: Normally 0 for PC, 1000 for Sun, Mac, and /*
          /* Apollo, 2000 for VAX D-float, 3000 for VAX G-float /*
          /* Add 1 for text variables. /*
          /* See LOAD in reference section of guide for more info. */

int mrows; /* row dimension */
int ncols; /* column dimension */
int imagf; /* imaginary flag */
char *pname; /* pointer to matrix name */
double *preal; /* pointer to real data */
double *pimag; /* pointer to imag data */
{
    Fmatrix x;
    int mn;
    x.type = type;
    x.mrows = mrows;
    x.ncols = ncols;
    x.imagf = imagf;
    x.namlen = strlen(pname) + 1;
    mn = x.mrows * x.ncols;

    fwrite(&x, sizeof(Fmatrix), 1, ptr);
    fwrite(pname, sizeof(char), (int)x.namlen, ptr);
    fwrite(preal, sizeof(double), mn, ptr);
    if (imagf) {
        fwrite(pimag, sizeof(double), mn, ptr);
    }
}
}

```

Mass Discrimination Software

```

/*****
* File: mass.c
*
* Copyright 1994 MIT Research Laboratory for Electronics
*
* Contents: Linear Dashpot
* Created: 05/04/94
* Author: Lee Beauregard
* Revision: 4.1 (5/04/95)
*
* Remarks: presents II 2AFC mass stimuli at 1 KHZ with a
* fixed displacement of 25mm & logs position, velocity, accel
* and force at a 200 hz sampling rate into MAT-file format.
*****/

/* INCLUDE FILES
*****/
#include "stdio.h"
#include "stdlib.h"
#include "dos.h"
#include "alloc.h"
#include "time.h"
#include "/ASO1600/C/userprot.h"

/* LOCAL VARIABLES
*****/
DDH DAS1600; /* Device Handle */
char NumOfBoards; /* Number of boards in DAS1600.cfg */
int Err; /* Function return error flag */
int da_value; /* Storage for D/A value */
long ad_value; /* Storage for A/D value */

/* CONSTANTS
*****/
#define DEFAULT_FILE "dashpot.cfg"
#define BASE 0x300 // base address of das 1600 board
#define COUNT_1 0x0d // counter 1 address
#define COUNT_2 0x0e // counter 2 address
#define CONTROL 0x0f // timer control byte address

/* TYPES
*****/
typedef struct config_info {
int num_trials; /* Number of trials */
int *trial; /* Stiffness i */
double stiff_1; /* Compliance 1 (mm/N) */
double stiff_2; /* Compliance 2 (mm/N) */
int feedback; /* Feedback status flag */
char subject_name[40]; /* Subject's name */
char test_date[40]; /* Date of Experiment */
char hand[40]; /* Hand evaluated */
char age[20]; /* Subject's age */
char test_type[40]; /* Type of experiment */
}

```

```

char    experimenter[40];    /* Experiementer's name */
} CONFIG_INFO;

typedef struct {
    long    type;            /* type */
    long    mrows;          /* row dimension */
    long    ncols;          /* column dimension */
    long    imagf;          /* flag indicating imag part */
    long    namlen;         /* name length (including NULL) */
} Fmatrix;

/* LOCAL FUNCTIONS
******/
void    initialize_hardware();
void    initialize_timer();
void    cursor_off();
void    cursor_on();
void    motor_output();
void    print_config();
void    print_labels();
void    read_config();
double  read_velocity();
double  read_force();
double  read_position();
double  read_accel();
double  actual_mm( double xdc );
double  actual_velocity( double v_dc );
double  actual_newtons( double f_vdc );
double  actual_accl( double a_dc );
int     rnd_stim(int n, int *s);
int     rnd_position();

CONFIG_INFO *create_config();

/* LOCAL VARIABLES
******/
CONFIG_INFO *config;        /* Configuration information */

/* MAIN
******/
void main(argc, argv)
int     argc;                /* number of command line arguments */
char    *argv[];            /* command line arguments */
{
    FILE    *fp,*ptr;        /* data and reponse file pointers */
    time_t  t;
    double  v_vdc;          /* velocity measured in volts dc */
    double  a_vdc;          /* aceeleration in volts */
    double  x_vdc;          /* position in volts dc */
    double  f_vdc;          /* force in volts dc */
    double  position;       /* position (mm) */
    double  velocity;       /* velocity in mm/s */
    double  force;          /* force in newtons */
    double  acceleration;   /* acceleration in mm/s/s */
    double  f_offset,a_offset; /* force offset */
    double  drive;          /* linear motor drive (v) */

```

```

double    drive_force;          /* driving force to be generated */
double    mass;                 /* mass stimuli variable (kg) */
double    position_data[1500]; /* position data array */
double    velocity_data[1500]; /* velocity data array */
double    force_data[1500];    /* force data array */
double    accel_data[1500];    /* acceleration data array */
double    select=0;            /* data logger selector */
double    stim_real[2];

int        value;               /* random number */
int        i,j,l, n_trial;      /* trial number */
int        index;              /* index */
int        stim[256];          /* array holding stim presentation order */
int        x_data[256];        /* array holding roving distance values */
int        response[256];      /* array holding subject response order */
int        x_max;              /* maximum position to apply force */
int        c1=0, c2=0;         /* counters for correct stimuli detection */
int        missed1,missed2;    /* counters for missed detections */
int        flag,wait,rate=0;   /* flags for data logging */
int        delta_count;        /* count difference in timer routine */
int        delta=0,error=0;    /* sampling rate error values */
int        old_count,new_count,dum; /* lsb,msb timer counter values */

char        filename[40];      /* filename */
char        datafile[40];     /* data file name */
char        matfile[40];      /* mat file name */
char        c;                 /* subject's response */
char        xmat[4];          /*MAT file variables */
char        fmat[4];
char        vmat[4];
char        amat[4];
char        string[3];
char        *posx="x";
char        *forf="f";
char        *velv="v";
char        *acca="a";
double     trial[64];
double     resp[64];

/* Configuration information */

if (argc >= 3) {
    strcpy(filename, argv[1]);
    strcpy(datafile, argv[2]);
    strcpy(matfile, argv[3]);
}
else {
    strcpy(filename, DEFAULT_FILE);
    strcpy(datafile, "mass.dat");
    strcpy(matfile, "mass.mat");
}
config = create_config();
read_config(filename);

n_trial = config->num_trials;
rnd_stim(n_trial, stim);
// generate random stim array

```

```

clrscr();

strcpy(xmat, posx);
strcpy(fmat, forf);
strcpy(vmat, velv);
strcpy(amat, acca);

//      DETERMINE FORCE OFFSET

initialize_hardware();
drive=0.0;
motor_output(drive);

printf("Hit the space bar for force sensor calibration\n");
while( !kbhit());
c = getch();

force = read_force();
f_offset = -21.195*force;
a_vdc = read_accel();
a_offset = 3331.8*a_vdc;

for (n_trial = 0; n_trial < config->num_trials; n_trial++) {

initialize_timer();

//      RESET GRASPER TO HOME POSITION

drive = -0.10;
motor_output(drive);
x_vdc = read_position();
position = actual_mm( x_vdc );
while ( (!kbhit()) & (position > 1.5)){
x_vdc = read_position();
position = actual_mm( x_vdc );
}

cursor_off();
print_labels(n_trial);

/* RANDOMIZE BETWEEN 2 MASSES COEFFICIENTS */

if (stim[n_trial] == 1)
mass = config->stiff_1;
else
mass = config->stiff_2;

x_max = 10.0; // fixed displacement of 35mm
x_data[n_trial] = x_max; // record distance
x_vdc = read_position(); // measure initial position
position = actual_mm( x_vdc );

select = 0.0; // data log every fourth trial
wait = 1; // wait used to store data at 500hz
l = 0; // reset data array subscript

```

```

    flag = 1;

/*      CONTROL LOOP      */

while( position < x_max) {

    if ( flag == 1 ){
        outputb( BASE + CONTROL, 0x80 );           // control byte to read C2 status
        old_count = inportb( BASE + COUNT_2 );     // read lsb
        dum = inportb( BASE + COUNT_2 );          // dummy msb read
        flag = 0;
    }

    do{
        // wait loop for 1msec
        outputb( BASE + CONTROL, 0x80 );           // control byte for C2
        new_count = inportb( BASE + COUNT_2 );     // read lsb
        dum = inportb( BASE + COUNT_2 );          // dummy read msb
        delta_count = old_count - new_count;
    } while ( delta_count == 0 );

/*      READ SENSOR DATA      */
    v_vdc = read_velocity();
    velocity = actual_velocity( v_vdc );
    x_vdc = read_position();
    position = actual_mm( x_vdc );
    f_vdc = read_force();
    force = actual_newtons( f_vdc ) - f_offset;
    a_vdc = read_accel();
    acceleration = actual_accl( a_vdc ) - a_offset;

/*      CHECK COUNT VALUE FOR ONE DECREMENT      */
    if (( delta_count != 1 ) && (delta_count != -255 ) && (select == 0)){
        error = n_trial + 1;
        delta = delta_count;
        cursor_on();
    }

/*      GENERATE DRIVE FORCE      */
    drive = 0.0;
    drive_force = (mass*acceleration/1000)-0.5;

    if (drive_force < 30.0 )
        drive = -0.0670*drive_force;
    else {
        drive=0.0;
        motor_output(drive);
        printf(" Program terminated\n");
        printf(" Applied Force = %5.2lf\t Drive Force = %5.2lf\n", force, drive_force);
        cursor_on();
        exit(0);
    }

    if (( l < 1500 ) && (rate == 0) && (select == 0.0)){
        velocity_data[l] = velocity;
        position_data[l] = position;
        force_data[l] = force;
    }
}

```



```

        accel_data[l] = acceleration;
        l++;
    }

    wait++; // Sample at 200 hz
    rate = wait%5;

    old_count = new_count;

} // End of while loop

drive = 0.0; // Shut drive off run
motor_output(drive);

/*          RECORD SUBJECT'S RESPONSE          */

printf("Type '1' for the greater mass, Type '2' for the lesser mass\n");
c = getch();

while(( c != '1') & (c != '2')){
    printf("Type '1' for the greater mass, Type '2' for the lesser mass\n");
    c=getch();
}
switch( c ){
    case '1':
        response[n_trial] = 1;
        resp[n_trial] = 1.0;
        break;
    case '2':
        response[n_trial] = 2;
        resp[n_trial] = 2.0;
        break;
}

/*          FEEDBACK PRESENTATION          */

if (config->feedback == 1){
    if (response[n_trial] == stim[n_trial])
        printf("Correct Response\n");
    else printf("Incorrect Response\n");
}

/*          WRITE VELOCITY, FORCE AND POSITION DATA TO MAT-FILE
-----*/

if ((ptr=fopen(matfile, "a+b")) == NULL){
    printf("can not open file\n");
    return;
}

j=n_trial+1;

if (stim[n_trial] == 1) trial[n_trial]=1.0;

```

```

else trial[n_trial]=2.0;

itoa(j, string, 10);
strcat(xmat, string);
strcat(fmat, string);
strcat(vmat, string);
strcat(amat, string);

/*      printf("%s\n", xmat);
      printf("%s\n", fmat);
      printf("%s\n", vmat);
      printf("%s\n", amat); */

savemat(ptr, 0, xmat, 1, 1, 0, position_data, (double *)0);
savemat(ptr, 0, fmat, 1, 1, 0, force_data, (double *)0);
savemat(ptr, 0, vmat, 1, 1, 0, velocity_data, (double *)0);
savemat(ptr, 0, amat, 1, 1, 0, accel_data, (double *)0);
savemat(ptr, 0, "trmat", 64, 1, 0, trial, (double *)0);           //array holding stim order
savemat(ptr, 0, "rspmat", 64, 1, 0, resp, (double *)0);         //array holding response order
fclose(ptr);

strcpy(xmat, posX);
strcpy(fmat, forf);
strcpy(vmat, velv);
strcpy(amat, acca);
cursor_on();
}          /* End of for loop          */

drive = 0.0;          /* Shut off drive after all trials are run          */
motor_output(drive); /* END OF ALL TRIALS          */

/*          WRITE TO RESPONSE DATA FILE          */

if ((fp=fopen(datafile,"a")) == NULL){
    printf("can not open file\n");
    return;
}
t = time(NULL);
if ( error > 0 ) fprintf(fp, "sample rate error at trial %d\t delta = %d\n",error,delta);
fprintf(fp, "%s\n", config->subject_name);
fprintf(fp, "%s\n", config->age);
fprintf(fp, "%s\n", config->hand);
fprintf(fp, "%s", ctime(&t));
fprintf(fp, "%s\n", config->test_date);
fprintf(fp, "%s\n", config->test_type);
fprintf(fp, "%s\n", config->experimenter);
fprintf(fp, "Feedback Status (1=on 0=off): %d\n", config->feedback);
fprintf(fp, "Reference Mass:\t %4.3f\n", config->stiff_1);
fprintf(fp, "Mass #2:\t %4.3f\n", config->stiff_2);
fprintf(fp, "TRIAL#\t STIMULUS\t RESPONSE\t ROVING DISPLACEMENT\n");
for ( i=0; i < config->num_trials; i++) {
    j=i+1;
    fprintf(fp, "%3.1d\t %5.1d\t %12.1d\t %18.1d\n",j,stim[i],response[i],x_data[i]);
}
fprintf(fp, "\n");

```

```
/* CALCULATE CONFUSION MATRIX AND WRITE TO DATA FILE */

for (n_trial = 0; n_trial < config->num_trials; n_trial++) {
    if (stim[n_trial] == 1){
        if (stim[n_trial] == response[n_trial]) c1=c1+1;
    }
    if (stim[n_trial] == 2){
        if (stim[n_trial] == response[n_trial]) c2=c2+1;
    }
}

missed1 = (config->num_trials)/2 - c1;
missed2 = (config->num_trials)/2 - c2;
fprintf(fp, "Mass 1 was correctly detected %d times\n", c1);
fprintf(fp, "Mass 1 was missed %d times\n", missed1);
fprintf(fp, "Mass 2 was correctly detected %d times\n", c2);
fprintf(fp, "Mass 2 was missed %d times\n", missed2);
fprintf(fp, "\n");
fclose(fp);

cursor_on();
}
```

Velocity/Acceleration Discrimination Software

```

/*****
* File: vel.c
*
* Copyright 1995 MIT Research Laboratory for Electronics
*
* Contents: Velocity Discrimination Experiments
* Created: 04/10/95
* Author: Lee Beauregard
* Revision: 1.1
*
* Remarks: presents 11 2AFC velocity stimuli at 1 KHZ with a
* fixed displacement of 25mm & logs position, velocity, accel
* and force at a 200 hz sampling rate into MAT-file format.
* Velocity is controlled thru a proportional gain feedback loop
* with friction compensation. For safety, program will terminate
* if a subject applies a resisting force > 2.5N.
*****/

/* INCLUDE FILES
*****/
#include "stdio.h"
#include "stdlib.h"
#include "dos.h"
#include "alloc.h"
#include "time.h"
#include "math.h"
#include "/ASO1600/C/userprot.h"

/* LOCAL VARIABLES
*****/
DDH DAS1600; /* Device Handle */
char NumOfBoards; /* Number of boards in DAS1600.cfg */
int Err; /* Function return error flag */
int da_value; /* Storage for D/A value */
long ad_value; /* Storage for A/D value */

/* CONSTANTS
*****/
#define DEFAULT_FILE "vel.cfg"
#define BASE 0x300 // base address of das 1600 board
#define COUNT_1 0x0d // counter 1 address
#define COUNT_2 0x0e // counter 2 address
#define CONTROL 0x0f // timer control byte address

/* TYPES
*****/
typedef struct config_info {
int num_trials; /* Number of trials */
int *trial; /* Trial */
double stiff_1; /* Velocity Stimulus 1 */
double stiff_2; /* Velocity Stimulus 2 */
int feedback; /* Feedback status flag */
char subject_name[40]; /* Subject's name */
char test_date[40]; /* Date of Experiment */
}

```

```

char    hand[40];           /* Hand evaluated */
char    age[20];           /* Subject's age */
char    test_type[40];     /* Type of experiment */
char    experimenter[40];  /* Experiementer's name */
} CONFIG_INFO;

typedef struct {
    long    type;           /* type */
    long    mrows;         /* row dimension */
    long    ncols;         /* column dimension */
    long    imagf;         /* flag indicating imag part */
    long    namlen;        /* name length (including NULL) */
} Fmatrix;

/* LOCAL FUNCTIONS
*****/
void    initialize_hardware();
void    initialize_timer();
void    cursor_off();
void    cursor_on();
void    motor_output();
void    print_config();
void    print_labels();
void    read_config();
double  read_velocity();
double  read_force();
double  read_position();
double  read_accel();
double  actual_mm( double xdc );
double  actual_velocity( double v_dc );
double  actual_newtons( double f_vdc );
double  actual_accl( double a_dc );
int     rnd_stim(int n, int *s);
int     rnd_position();

CONFIG_INFO *create_config();

/* LOCAL VARIABLES
*****/
CONFIG_INFO *config;      /* Configuration information */

/* MAIN
*****/
void main(argc, argv)
int     argc;             /* number of command line arguments */
char    *argv[];         /* command line arguments */
{
    FILE    *fp, *ptr;    /* data and reponse file pointers */
    double  v_vdc;       /* velocity measured in volts dc */
    double  a_vdc;       /* acceleration in volts */
    double  x_vdc;       /* position in volts dc */
    double  f_vdc;       /* force in volts dc */
    double  position;    /* position (mm) */
    double  velocity;    /* velocity in mm/s */
    double  force;       /* force in newtons */
    double  acceleration; /* acceleration in mm/s/s */

```

```

double    f_offset,a_offset;    /* force offset */
double    drive;                /* linear motor drive (v) */
double    drive_force;          /* driving force to be generated */
double    vel_stim;              /* damping coefficient (Ns/mm) */
double    position_data[1500];  /* position data array */
double    velocity_data[1500];  /* velocity data array */
double    force_data[1500];     /* force data array */
double    acce[_data[1500];     /* acceleration data array */
double    select=0;             /* data logger selector */
double    stim_real[2];
double    gain_v;               /* feedback gain for velocity control */
double    gain_c;               /* control gain to minimize disturbance effects */

int        value;                /* random number */
int        i,j,l, n_trial;       /* trial number */
int        index;                /* index */
int        stim[256];            /* array holding stim presentation order */
int        x_data[256];          /* array holding roving distance values */
int        response[256];        /* array holding subject response order */
int        x_max;                /* maximum position to apply force */
int        c1=0, c2=0;           /* counters for correct stimuli detection */
int        missed1,missed2;      /* counters for missed detections */
int        flag,wait,rate=0;     /* flags for data logging */
int        delta_count;          /* count difference in timer routine */
int        delta=0,error=0;      /* sampling rate error values */
int        old_count,new_count,dum; /* lsb,msb timer counter values */

char        filename[40];         /* filename */
char        datafile[40];         /* data file name */
char        matfile[40];          /* mat file name */
char        c;                    /* subject's response */
char        xmat[4];              /*MAT file variables */
char        fmat[4];
char        vmat[4];
char        amat[4];
char        string[3];
char        *posx="x";
char        *forf="f";
char        *velv="v";
char        *acca="a";
double     trial[64];
double     resp[64];

/* Configuration information */
if (argc >= 3) {
    strcpy(filename, argv[1]);
    strcpy(datafile, argv[2]);
    strcpy(matfile, argv[3]);
}
else {
    strcpy(filename, DEFAULT_FILE);
    strcpy(datafile, "vel.dat");
    strcpy(matfile, "vel.mat");
}
config = create_config();
read_config(filename);

```

```

n_trial = config->num_trials;
rnd_stim(n_trial, stim); // generate random stim array
clrscr();
strcpy(xmat, posx);
strcpy(fmat, forf);
strcpy(vmat, velv);
strcpy(amat, acca);

initialize_hardware();
drive=0.0;
motor_output(drive);
printf("Hit the space bar for force sensor calibration\n");
while( !kbhit());
c = getch();
force = read_force();
f_offset = -22.863*force;
a_vdc = read_accel();
a_offset = 3310.4*a_vdc;

for (n_trial = 0; n_trial < config->num_trials; n_trial++) {
initialize_timer();
// RESET GRASPER TO HOME POSITION
drive = -0.10;
motor_output(drive);
x_vdc = read_position();
position = actual_mm( x_vdc );
while ( (!kbhit()) & (position > 1.5)){
x_vdc = read_position();
position = actual_mm( x_vdc );
}
drive = -0.02;
motor_output(drive);
printf("Hit the space bar to continue\n");
while( !kbhit());
c = getch();
cursor_off();
print_labels(n_trial);

/* RANDOMIZE BETWEEN 2 VELOCITY STIUMULI */
if (stim[n_trial] == 1)
vel_stim = config->stiff_1;
else
vel_stim = config->stiff_2;

x_max = 25.0; // fixed displacement of 35mm
x_data[n_trial] = x_max; // record distance
x_vdc = read_position(); // measure initial position
position = actual_mm( x_vdc );
select = 0.0; // data log every trial
wait = 1; // wait used to store data at 200hz
l = 0; // reset data array subscript
flag = 1;

/* CONTROL LOOP */
while( position < x_max) {

```

```

if ( flag == 1 ){
    outportb( BASE + CONTROL, 0x80 );           // control byte to read C2 status
    old_count = inportb( BASE + COUNT_2 );     // read lsb
    dum = inportb( BASE + COUNT_2 );         // dummy msb read
    flag = 0;
}

do{
    // wait loop for 1msec
    outportb( BASE + CONTROL, 0x80 );       // control byte for C2
    new_count = inportb( BASE + COUNT_2 );   // read lsb
    dum = inportb( BASE + COUNT_2 );       // dummy read msb
    delta_count = old_count - new_count;
} while ( delta_count == 0 );

/*      READ SENSOR DATA      */
v_vdc = read_velocity();
velocity = actual_velocity( v_vdc );
x_vdc = read_position();
position = actual_mm( x_vdc );
f_vdc = read_force();
force = actual_newtons( f_vdc ) - f_offset;
a_vdc = read_accel();
acceleration = actual_accl( a_vdc ) - a_offset;

/*      CHECK COUNT VALUE FOR ONE DECREMENT      */
if (( delta_count != 1 ) && (delta_count != -255 ) && (select == 0)){
    drive=0.0;
    motor_output(drive);
    printf("Sampling rate error. Delta Count = %d\n",delta_count);
    error = n_trial + 1;
    delta = delta_count;
    cursor_on();
    exit(0);
}

/*      GENERATE DRIVE FORCE      */
drive = 0.0;
gain_v = 0.05;
gain_c = 7.0;

if ( position > 0.0 ) {
    drive_force = gain_c*(gain_v*velocity - vel_stim - 0.5);           //CONTROL LAW
    if (( abs(drive_force) < 50.0 ) && ( abs(force) < 2.5 ))
        drive = -0.0670*drive_force;
    else {
        drive=0.0;
        motor_output(drive);
        printf(" Program terminated\n");
        printf(" Applied Force = %5.2lft Drive Force = %5.2lfn", force, drive_force);
        cursor_on();
        exit(0);
    }
}
motor_output(drive);
/*      LOG DATA EVERY TRIAL      */
if (( l < 1500 ) && (rate == 0) && (select == 0.0)){
    velocity_data[l] = velocity;
}

```



```

        position_data[l] = position;
        force_data[l] = force;
        accel_data[l] = acceleration;
        l++;
    }
    wait++; /* sample at 200 hz */
    rate = wait%10;
    old_count = new_count;
} /* End of while loop */
drive = 0.0; /* Shut drive off run */
motor_output(drive);
/* RECORD SUBJECT'S RESPONSE */
printf("Type '1' for the greater velocity, Type '2' for the lesser velocity\n");
c = getch();
while((c != '1') & (c != '2')){
    printf("Type '1' for the greater velocity, Type '2' for the lesser velocity\n");
    c=getch();
}
switch( c ){
case '1':
    response[n_trial] = 1;
    resp[n_trial] = 1.0;
    break;
case '2':
    response[n_trial] = 2;
    resp[n_trial] = 2.0;
    break;
}
/* FEEDBACK PRESENTATION */

if (config->feedback == 1){
    if (response[n_trial] == stim[n_trial])
        printf("Correct Response\n");
    else printf("Incorrect Response\n");
}
/* WRITE VELOCITY, ACCEL, FORCE AND POSITION DATA TO MAT-FILE
-----*/
if ((ptr=fopen(matfile, "a+b")) == NULL){
    printf("can not open file\n");
    return;
}
j=n_trial+1;
if (stim[n_trial] == 1) trial[n_trial]=1.0;
else trial[n_trial]=2.0;
itoa(j, string, 10);
strcat(xmat, string);
strcat(fmat, string);
strcat(vmat, string);
strcat(amat, string);
savemat(ptr, 0, xmat, 1, 1, 0, position_data, (double *)0);
savemat(ptr, 0, fmat, 1, 1, 0, force_data, (double *)0);
savemat(ptr, 0, vmat, 1, 1, 0, velocity_data, (double *)0);
savemat(ptr, 0, amat, 1, 1, 0, accel_data, (double *)0);
savemat(ptr, 0, "trmat", 64, 1, 0, trial, (double *)0); //array holding stim order
savemat(ptr, 0, "rspmat", 64, 1, 0, resp, (double *)0); //array holding response order
fclose(ptr);

```

```

        strcpy(xmat, posx);
        strcpy(fmat, forf);
        strcpy(vmat, velv);
        strcpy(amat, acca);
        cursor_on();
    }
    /* End of for loop */
    drive = 0.0; /* Shut off drive after all trials are run */
    motor_output(drive); /* END OF ALL TRIALS */

    /* WRITE TO RESPONSE DATA FILE */
    if ((fp=fopen(datafile,"a")) == NULL){
        printf("can not open file\n");
        return;
    }
    if ( error > 0 ) fprintf(fp, "sample rate error at trial %d\t delta = %d\n",error,delta);
    fprintf(fp, "%s\n", config->subject_name);
    fprintf(fp, "%s\n", config->age);
    fprintf(fp, "%s\n", config->hand);
    fprintf(fp, "%s\n", config->test_date);
    fprintf(fp, "%s\n", config->test_type);
    fprintf(fp, "%s\n", config->experimenter);
    fprintf(fp, "Feedback Status (1=on 0=off): %d\n", config->feedback);
    fprintf(fp, "Reference Velocity:\t %4.3f\n", config->stiff_1);
    fprintf(fp, "Velocity #2:\t %4.3f\n", config->stiff_2);
    fprintf(fp, "TRIAL#\t STIMULUS\t RESPONSE\t ROVING DISPLACEMENT\n");
    for ( i=0; i < config->num_trials; i++) {
        j=i+1;
        fprintf(fp, "%3.1d\t %5.1d\t %12.1d\t %18.1d\n",j,stim[i],response[i],x_data[i]);
    }
    fprintf(fp, "\n");
    /* CALCULATE CONFUSION MATRIX AND WRITE TO DATA FILE */
    for (n_trial = 0; n_trial < config->num_trials; n_trial++) {
        if (stim[n_trial] == 1){
            if (stim[n_trial] == response[n_trial]) c1=c1+1;
        }
        if (stim[n_trial] == 2){
            if (stim[n_trial] == response[n_trial]) c2=c2+1;
        }
    }
    missed1 = (config->num_trials)/2 - c1;
    missed2 = (config->num_trials)/2 - c2;
    fprintf(fp, "Velocity 1 was correctly detected %d times\n", c1);
    fprintf(fp, "Velocity 1 was missed %d times\n", missed1);
    fprintf(fp, "Velocity 2 was correctly detected %d times\n", c2);
    fprintf(fp, "Velocity 2 was missed %d times\n", missed2);
    fprintf(fp, "\n");
    fclose(fp);
    cursor_on();
}

```

The Remaining Software Code consists of the same subroutine functions listed in the Viscosity Discrimination Software Section.

Bibliography

- Berliner, J.E. & Durlach, N.I. (1973). Intensity perception IV: Resolution in roving-level discrimination. *Journal of the Acoustical Society of America*, **53**, 1270-1287.
- Bizzi, E., Accornero, N. Chapple, W. and Hogan N. (1984). Posture control and trajectory formation during arm movements. *The Journal of Neuroscience*. **4**, 2738-2744.
- Clark, F.J., and Horch, K.W. (1986). Kinesthesia. *Handbook of Perception and Human Performance, Vol. 1, Sensory processes and Perception, Chapter 25*. Wiley and sons.
- Durlach, N.I., Delhorne, L.A., Wong, A., Ko, W.Y., Rabinowitz, W.M. & Hollerbach, J. (1989). Manual discrimination and identification of length by the finger-span method. *Perception and Psychophysics*, **46**, 29-38.
- Durlach, N.I. (1968). A decision model for psychophysics. *Unpublished laboratory notes, Sensory Communication Group, Research Laboratory of Electronics, MIT*. pp. 1-19.
- Hogan, N. (1984). An organizing principle for a class of voluntary movements. *The Journal of Neuroscience*. **4**, 2745-2754.
- Johansson, R.S. & Cole, K.J. (1992). Sensory-motor coordination during grasping and manipulative actions. *Current Opions in Neurobiology*, **2**, 815-823.
- Jones, L.A. (1986). Perception of force and weight: theory and research. *Psychological Bulletin*, **100**, 29-42.
- Jones, L.A. (1989). Matching forces: constant errors and differential thresholds. *Perception*, **18**, 681-687.
- Jones, L.A., & Hunter I.W. (1990). A perceptual analysis of stiffness. *Experimental Brain Research*, **79**, 150-156.
- Jones, L.A., & Hunter I.W. (1992a). Differential thresholds for limb movement measured using adaptive techniques. *Perception and Psychophysics*, **52**, 529-535.
- Jones, L.A., & Hunter I.W. (1992b). Human operator perception of mechanical variables and their effects on tracking performance. *Winter Annual Meeting of the American Society of Mechanical Engineers: Advances in Robotics*, **42**, 49-53.
- Jones, L.A., & Hunter I.W. (1993). A perceptual analysis of viscosity. *Experimental Brain Research*, **94**, 343-351.
- Keele, S.W. (1986). Motor control. *Handbook of Perception and Human Performance, Vol. 2, Chapter 30*. Wiley and sons.

- Klatzksy, R.L., Lederman, S.J. and Matula, D.E. (1993). Imagined haptic exploration in judgments of object properties. *Journal of Experimental Psychology: Learning, Memory and Cognition*, **17**, 314-322.
- Klatzksy, R.L., Lederman, S.J. and Matula, D.E. (1993). Haptic exploration in the presence of vision. *Journal of Experimental Psychology: Human Perception and Performance*, **19**, 726-743.
- Klatzksy, R.L., and Lederman, S.J. (1992). Stages of manual exploration in haptic object identification. *Perception and Psychophysics*, **52**, 661-670.
- Kreifeldt, J.G. & Chuang M.C. (1979). Moment of inertia: psychophysical study of an overlooked sensation. *Science*, **206**, 588-590.
- Lederman, S.J. and Klatzksy, R.L. (1987). Hand movements: a window into haptic object recognition. *Cognitive Psychology*, **19**, 342-368.
- Lederman, S.J. and Klatzksy, R.L. (1990). Haptic object classification: Knowledge driven exploration. *Cognitive Psychology*, **22**, 421-459.
- Pang, X.D., Tan, H.Z., & Durlach, N.I. (1991). Manual discrimination of force using active finger motion. *Perception and Psychophysics*, **49**, 531-540.
- Milner, T.E. (1986). Judgment and control of velocity in rapid voluntary movements. *Experimental Brain Research*, **62**, 99-110.
- Rock, I., & Victor, J. (1963). Vision and Touch: An experimentally created conflict between the senses. *Science*, **143**, 594-596.
- Roland, P.E., & Ladegaard-Pedersen, H. (1977). A quantitative analysis of sensations of tension and of kinaesthesia in man: Evidence for a peripherally originating muscular sense and for a sense of effort. *Brain*, **100**, 671-692.
- Ross, H.E., Brodie E. & Benson, A.J. (1984). Mass discrimination during prolonged weightlessness. *Science*, **225**, 219-221.
- Ross, H.E. & Benson, A.J. (1986). The Weber fraction for the moment of inertia. in B. Berglund, U. Berglund, and R. Teghtsoonian (Eds) *Fechner Day 86* (pp. 71-76). Stockholm: International Society for Psychophysics.
- Scott-Blair, G.M., & Coppen, F.M. (1940). The subjective judgement of the elastic and plastic properties of soft bodies: The "differential thresholds" for viscosities and compression moduli. *Proceedings of Royal Society of London [Biol]*, **128**, 109-128.

- Shadmehr, R., Mussa-Ivaldi, F.A., and Bizzi, E. (1993). Postural force fields of the human arm and their role in generating multijoint movements. *The Journal of Neuroscience*, **13**, 45-62.
- Srinivasan, M.A. (1994b). Virtual Reality: Scientific and Technological Challenges, Chapter 4, Haptic Interfaces. *National Academy Press*, 161-187.
- Stevens, S.S., & Guairo M. (1964). Scaling of apparent viscosity. *Science*, **144**, 1157-1159.
- Tan, H.Z., Pang X.D., & Durlach, N.I. (1992). Manual resolution of length, force and compliance. *Winter Annual Meeting of the American Society of Mechanical Engineers: Advances in Robotics*, **42**, 13-18.
- Tan, H.Z., Durlach, N.I., Beauregard, G.L., & Srinivasan, M. A., (1995). Manual compliance discrimination of force using active finger motion: The roles of compliance, force and work cues. *Perception and Psychophysics*, **57**, 495-510.
- Watson, J.D.G., Colebatch, J.G., McCloskey, D.I. (1984). Effects of externally imposed elastic loads on the ability to estimate position and force. *Behavioural Brain Research*, **13**, 267-271.
- Wickens, S.W. (1986). The effects of control dynamics on performance. *Handbook of Perception and Human Performance*, Vol. 2, Chapter 39. Wiley and sons.
- Welch, R.B., & Warren, D.H. (1986). Intersensory interactions. *Handbook of Perception and Human Performance*, Vol. 1, Sensory processes and Perception, Chapter 25. Wiley and sons.